

[2018]

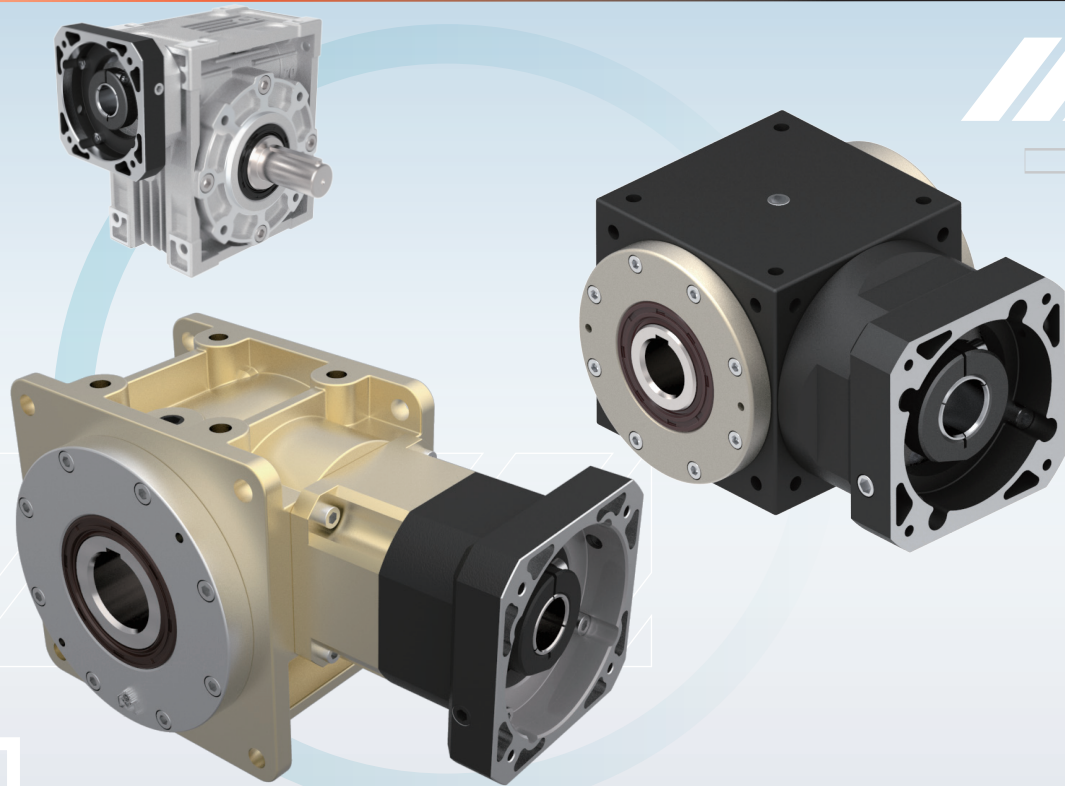

Right Angle Reducers 高精密伺服用直交軸減速機

利明牌
高精密
伺服用直交軸減速機
& 高精
密中空旋
轉平台減速機



Hollow Rotary Reducers 高精密中空旋轉平台減速機

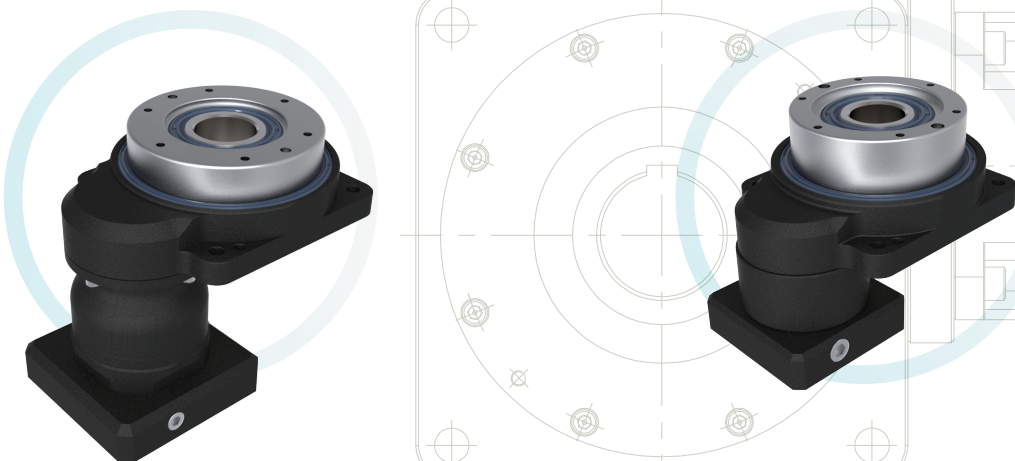

【 傳動裝置的解決方案 / 減速機的領導品牌 】

LI MING MACHINERY CO., LTD.

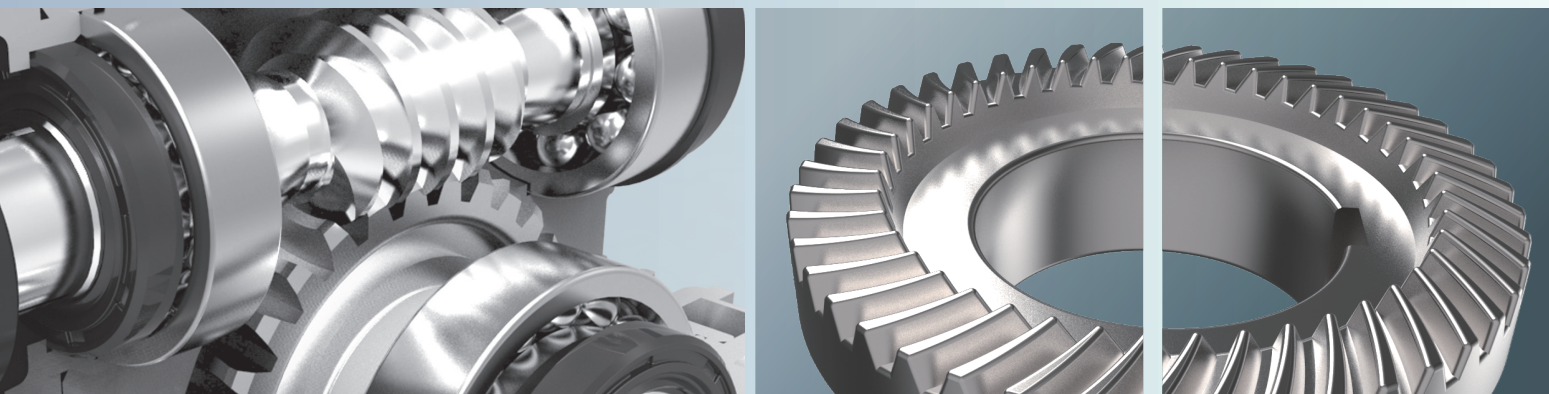

Quality First & Customer's Satisfaction

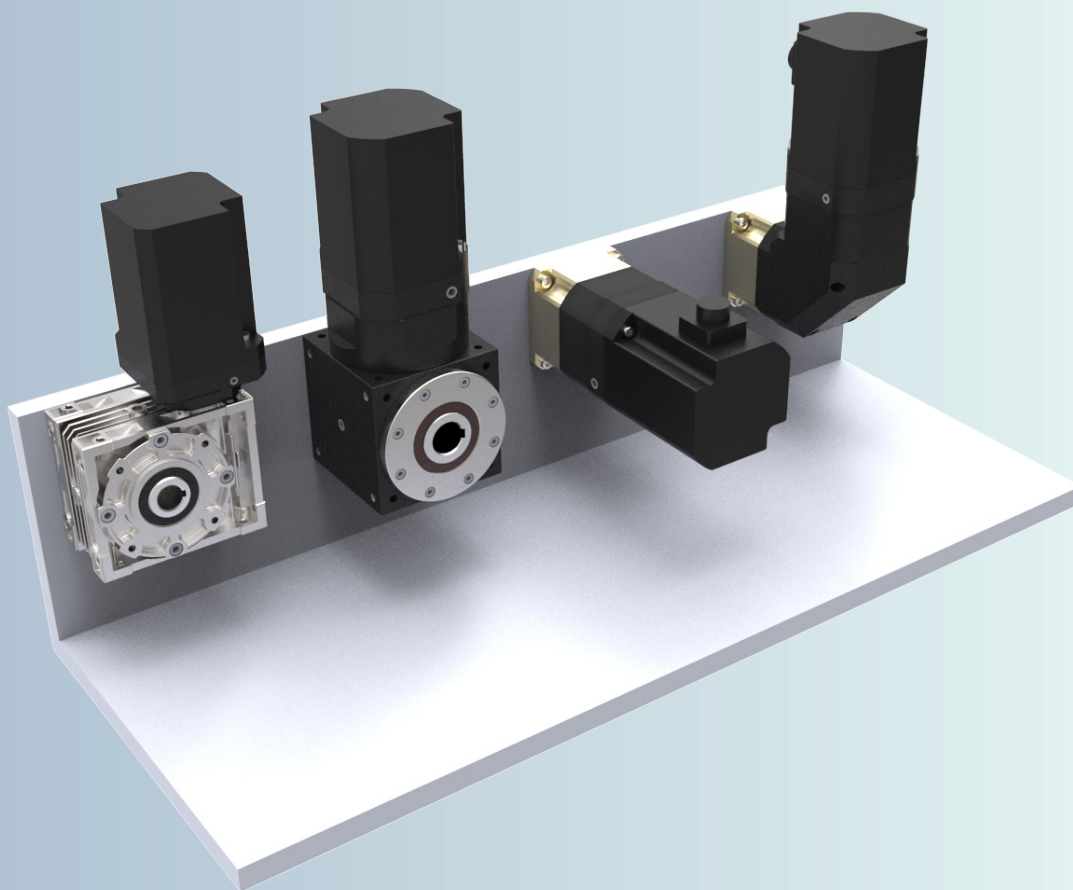

使用直交軸減速機，能更有效地利用空間

Space can be more effectively used by right angle reducer



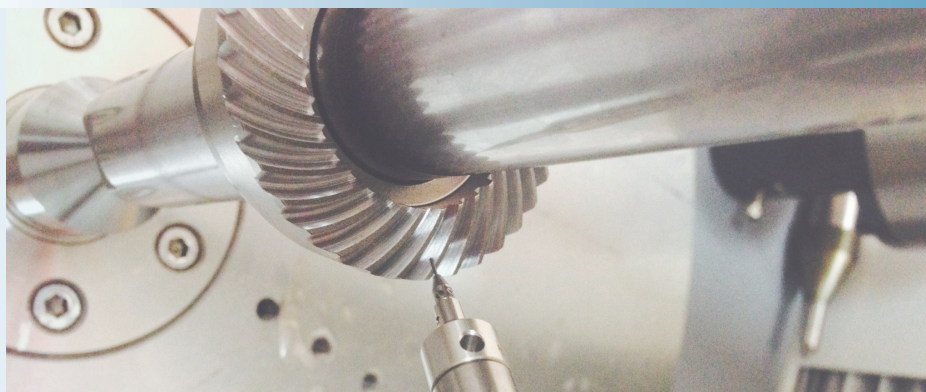

產品型號 MODEL		ST	FT	HY	HK	HF	WE	GT
頁次 Page								
		2	36	42	70	74	80	96
單段減速比 1-Stage		1、2、3 4、5	2、3、4 5	5、10、15	5、10、15	5、10、15	10、20、30 40、50、60	5、10、18
雙段減速比 2-Stage		10 ~ 50	10 ~ 50	25 ~ 150	-	-	-	25、50、100
最小背隙 Min. Backlash	arcmin	≤ 3	≤ 10	≤ 3	≤ 3	≤ 3	≤ 8	≤ 1
運轉一段時間 背隙變化	arcmin	≤ 2	≤ 2	≤ 2	≤ 2	≤ 2	≤ 10	≤ 2
容許最大入力馬力 Max. Input Power	kW	22	0.4	22	11	11	1.5	1.5
額定輸入轉速 Rated Input Speed	rpm	2,000~3,000	2,000~3,000	2,000~3,000	700~4,000	700~4,000	2,000	3,000
最大輸入轉速 Max. Input Speed	rpm	3,000~7,500	7,000	4,500~8,000	3,000~6,000	3,000~6,000	3,000	4,500~6,000
效率 Efficiency	%	94% ~ 98%	94% ~ 98%	93% ~ 96%	93% ~ 96%	≥ 96%	55% ~ 90%	≥ 98%

ST series

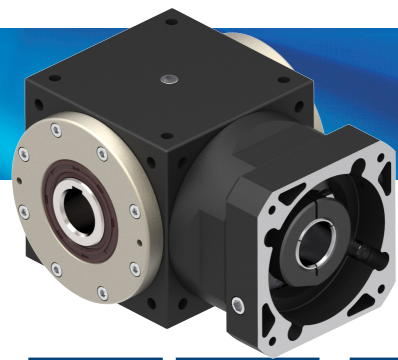

Indication of Model Numbers

機種型號表示

ST	90	F	N	B	5	L	P0
減速機機型 Type	型號 Model	入力表示 Input	出力表示 Output	軸承形式 Bearing	速比 Ratio	軸向 Shaft Direction	背隙等級 Backlash Class
ST	65 75 90 110 140 170 210	F: 入力法蘭 Input Flange R44: 減速機 Reducer 1-Stage: R44、R62... 2-Stage: R62S... 2-Stage (A-Type): R44A、R62A... D: 單入力軸心 (有鍵槽) Single Input Shaft (Keyway) D1: 單入力軸心 (無鍵槽) Single Input Shaft (No Keyway) Y: 雙入力軸心 (有鍵槽) Double Input Shaft (Keyway) Y1: 雙入力軸心 (無鍵槽) Double Input Shaft (No Keyway)	O: 出力中空軸 Hollow Output Shaft N: 單邊免鍵軸套 (有鍵槽) Single Clamping (Keyway) N1: 單邊免鍵軸套 (無鍵槽) Single Clamping (No Keyway) M: 雙邊免鍵軸套 Double Clamping S: 單出力軸心 (有鍵槽) Single Output Shaft (Keyway) S1: 單出力軸心 (無鍵槽) Single Output Shaft (No Keyway) V: 雙出力軸心 (有鍵槽) Double Output Shaft (Keyway) V1: 雙出力軸心 (無鍵槽) Double Output Shaft (No Keyway) P: 螺桿式 Ball Screw (75#~210#) 限用滾錐軸承 Taper Bearing Only	B: 滾珠軸承 Ball Bearing (65#~210#) (Ratio: 1~5) T: 滾錐軸承 Taper Bearing (75#~210#) (Ratio: 2~5)	單段 1-Stage 1, 2, 3, 4, 5 ----- 搭配單段 行星減速機 With 1-Stage Planetary Reducer 10 ~ 50 ----- 搭配雙段 行星減速機 With 2-Stage Planetary Reducer 75 ~ 500	L: 左軸 Left Shaft R: 右軸 Right Shaft ----- 1. 出力形式 N、S 可以選 擇軸向 Shaft direction is optional for output type N, S. ----- 2. 出力形式 P 為 R 軸向 Output type P only for R shaft.	P0 P1 P2

The Model & Ratio Table of Bevel Gear Reducer Assembly Planetary Reducer 傘齒輪減速機搭配行星減速機型號及速比一覽表

型號 Model	減速比 Ratio	法蘭盤框號 Flange Model	行星減速機框號 Planetary Reducer Model	單段行星減速機減速比 Ratio of 1-Stage Planetary Reducer 5、10	雙段行星減速機減速比 Ratio of 2-Stage Planetary Reducer 25、50、100
65		62	44		
75	1	62	44	搭配單段行星減速機減速比 Ratio of Bevel Gear Reducer Fitted with 1-Stage Planetary Reducer 10、15、20、25、30、40、50	搭配單段行星減速機減速比 Ratio of Bevel Gear Reducer Fitted with 1-Stage Planetary Reducer 75、100、125、150、200、 250、300、400、500
90	2	90	62		
110	3	90	80		
140	4	120	90		
170	5	142	120		
210		180	142		

Selection of Type

產品樣式選擇

入力形式 Input Type

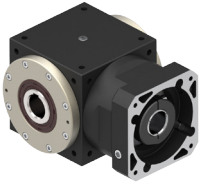
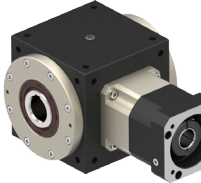
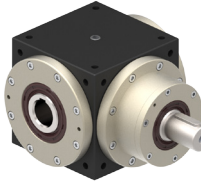
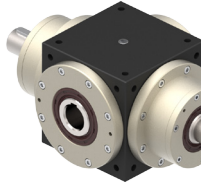
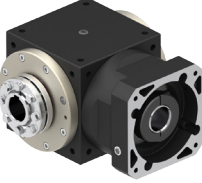
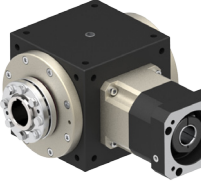
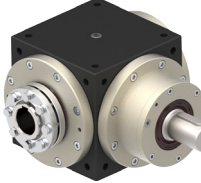
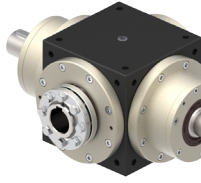
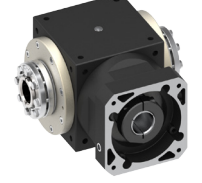
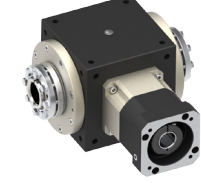
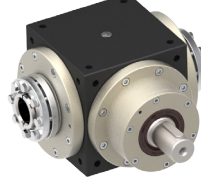
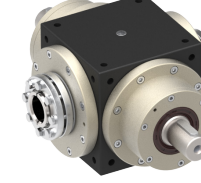
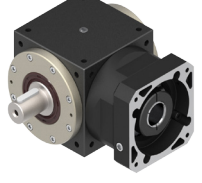
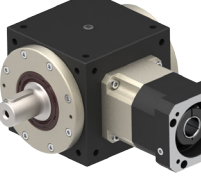
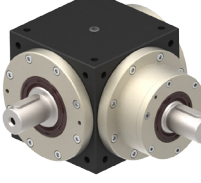
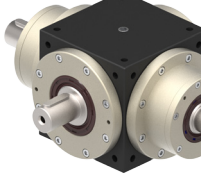
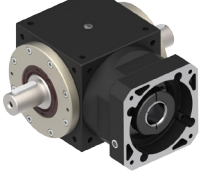
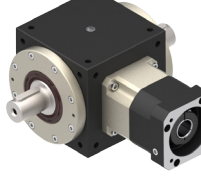
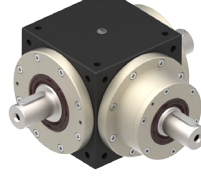
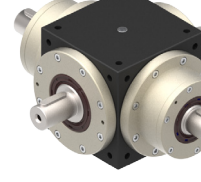
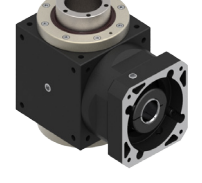
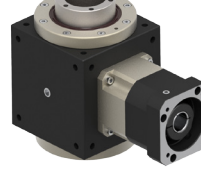
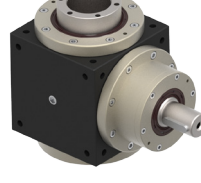
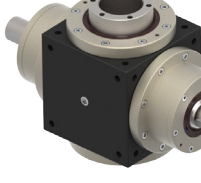
	F 入力法蘭 Input Flange	R 減速機 Reducer	D 單入力軸心 Single Input Shaft	Y 雙入力軸心 Double Input Shaft
O 出力中空軸 Hollow Output Shaft				
	FO	RO	DO	YO
N 單邊免鍵軸套 Single Clamping				
	FN	RN	DN	YN
M 雙邊免鍵軸套 Double Clamping				
	FM	RM	DM	YM
S 單出力軸心 Single Output Shaft				
	FS	RS	DS	YS
V 雙出力軸心 Double Output Shaft				
	FV	RV	DV	YV
P 螺桿式 Ball Screw				
	FP	RP	DP	YP

- 出力形式 N、S 可以選擇軸向。Shaft direction is optional for output type N, S.
- 出力形式 P 為 R 軸向。Output type P only for R shaft.

Rotating Direction

旋轉方向說明

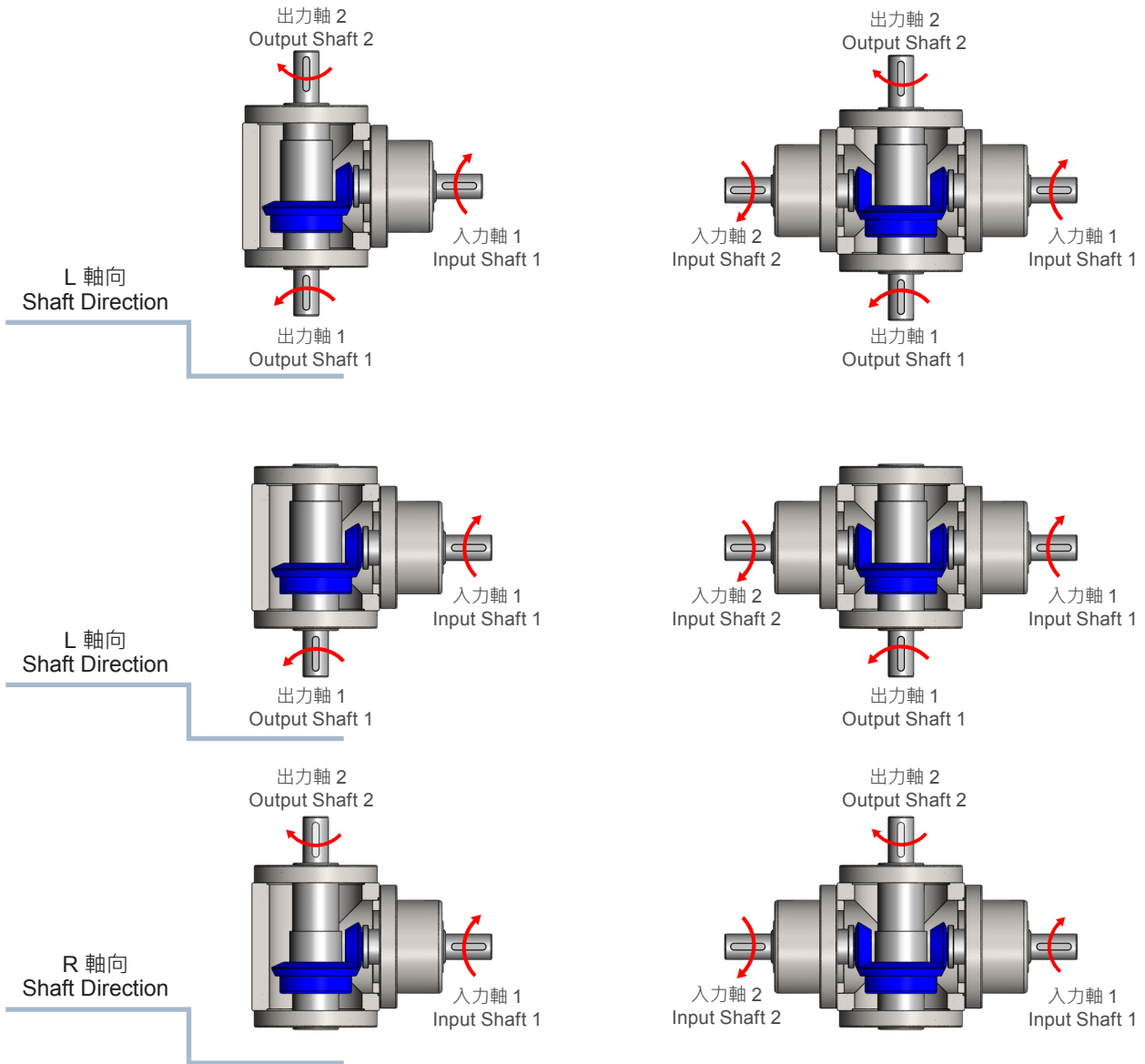
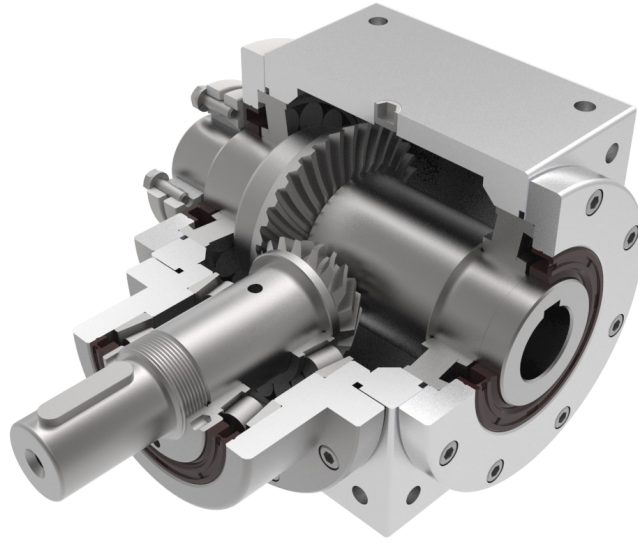

本公司出廠標準品使用「標準軸向」，R 軸向請於訂單上註明。
Standard product is L shaft direction, R shaft direction is optional.

Selection Direction of Installation

安裝方向選擇

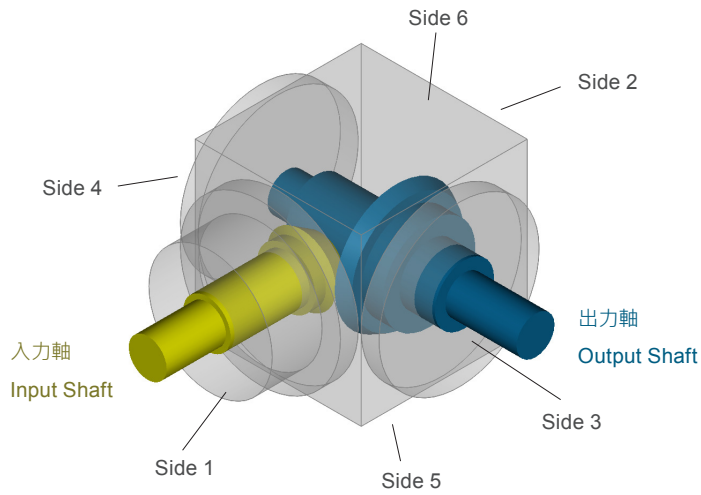

Side 1	Side 2
Side 3	Side 4 [Note 1]
Side 5	Side 6

[Note 1] 出力軸端端面基準線朝上時，需特別告知其使用方式。
Side 4 operation shall be avoid.

Features of ST Series

ST 系列產品特點

ST

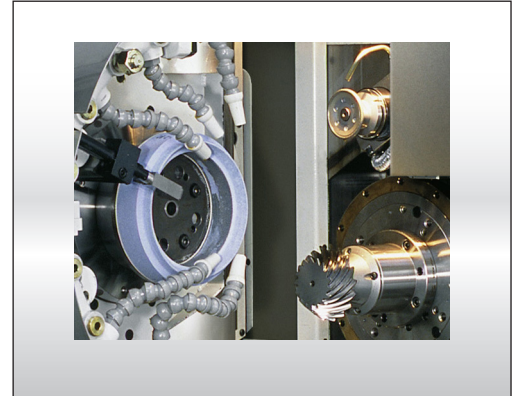
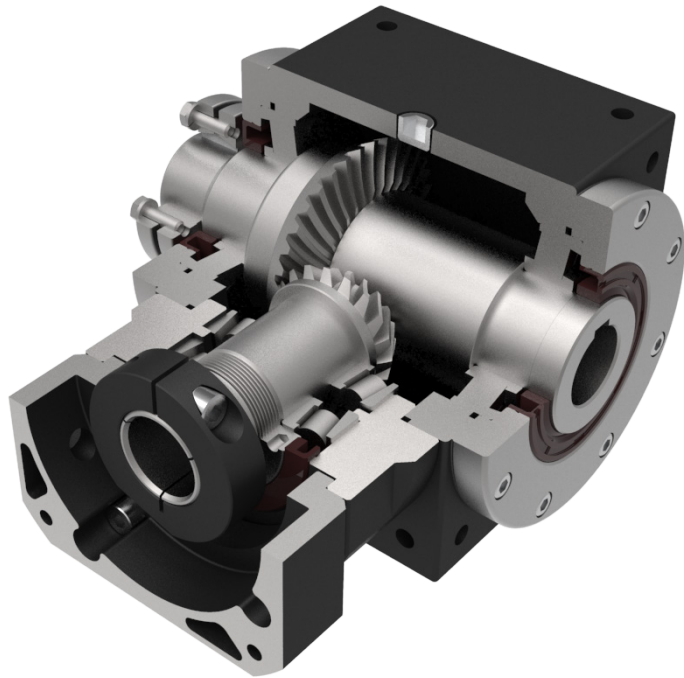

高強度、高精度螺旋傘齒輪

- 齒輪採高強力滲碳合金鋼，研磨精密度符合 AGMA12 級標準以內。

High precision grinded and carburized spiral bevel gears

- High precision grinded and carburized spiral bevel gears to meet standard AGMA12.

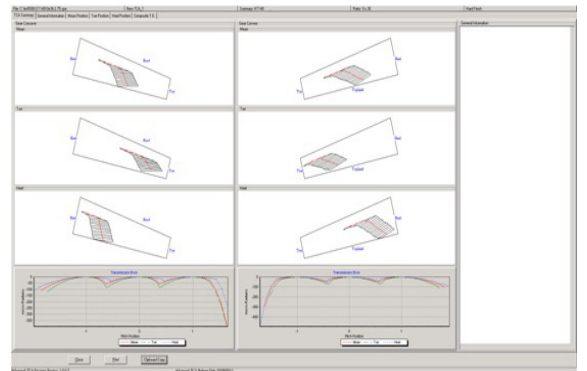
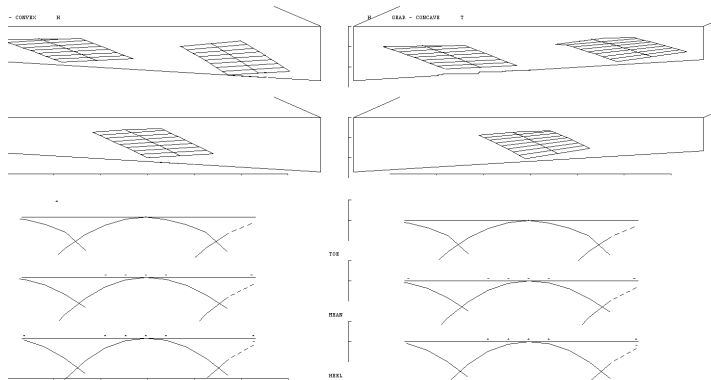

最優化的設計及 CAE 分析技術

- 採用 Gleason 參數齒輪設計軟件，得到最佳化接觸面積的齒印參數，保證了最高扭矩以及最小噪音。
- 並利用 3D-CAE 軟體的設計分析技術，對減速機整體強度及螺旋傘齒輪進行分析，增加齒輪系及減速機的使用壽命。

Optimized Design and CAE Analysis

- Use Gleason's design software to design new spiral bevel gears. Through the ideal gear contact pattern for application, achieve high permissible output torque.
- Employs 3D-CAE software for analysis and design, the software allows for analyzing the strength of the entire gear reducer and helical teeth. Increasing the service life of gears and the gear reducer.

Features of ST Series

ST 系列產品特點



低背隙

- 使用 Gleason 參數齒輪加工設備，加工研磨等級的螺旋傘齒輪，確保低背隙、低噪音。
- 背隙最小可達 2 弧分以內。

Low Backlash

- Using Gleason high precision CNC grinding machine to grinding the spiral bevel gears.
- Torsional backlash depending on design up to <2 arcmin.

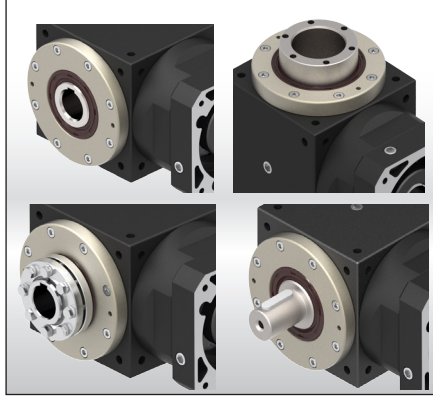

安裝位置

- 多重精密加工表面易於組裝，適用於任意安裝方向。
- 入出力軸的設計可以適用於各種工業上應用的需求。

Mounting Position

- Multiple precision machined surface is easy for assembly, suitable for any optional mounting orientation.
- Output shaft and input shaft are designed to suit for various industries applications.

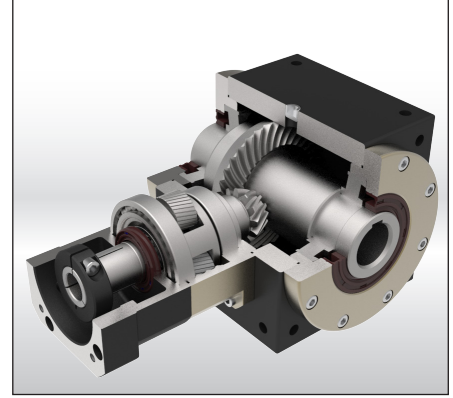

更高的減速比

- 高精密研磨的蝸線傘齒輪組結合最佳化設計的行星式齒輪組可以達到 500:1 的減速比。

More High Gear Ratio

- High precision grinded and carburized spiral bevel gears with optimal designed planetary gear can do ratio 500: 1.

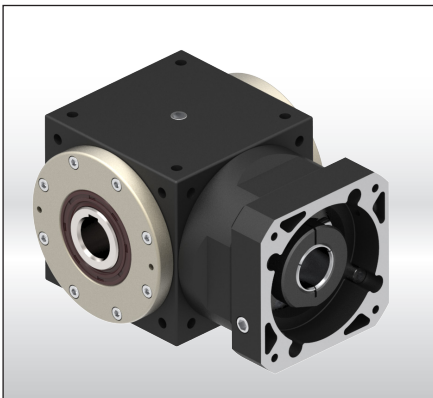

免保養

- 免保養無須更換潤滑油，運轉壽命長。

No Maintenance

- It features no maintenance and long service life.



高扭矩密度

- 一體式齒箱本體確保最大剛性與耐蝕性。
- 結構緊湊，富有剛性的設計保證了在小體積，重量輕的情況下能夠達到最高扭矩及較大的減速比。

High Output Torque

- The gear box is one-piece constructed to ensure the high rigidity and corrosion-resistant capability.

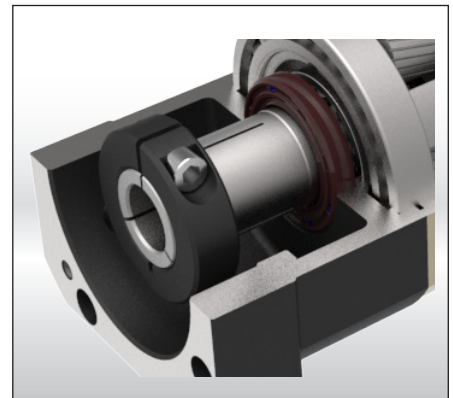

筒夾式連結機構

- 輸入端與馬達的連結採用筒夾式的鎖緊機構，並經動平衡分析，以確保在高輸入轉速下結合介面的同心度和平衡度，及零背隙的動力傳遞。

Collet Locking Mechanism

- The input-end and the motor are coupled through a collet locking mechanism. It has passed dynamical balance analysis to assure concentricity and balance on the connection and no backlash for power transmission while running at high speed.

Characteristic of ST Series

ST 系列產品特性

ST

單段減速機 1-Stage

規格 Model No.	代號	單位 Unit	速比 Ratio	65	75	90	110	140	170	210
額定輸出扭矩 / Rated Output Torque (Nominal output torque)	T_{2N}	Nm	1	25	45	78	150	360	585	1,300
			2	24	42	68	150	330	544	1,220
			3	18	33	54	120	270	450	1,020
			4	13	28	52	100	224	376	860
			5	12	25	40	85	196	320	740
最大加速扭矩 / Max. Acceleration Torque	T_{2B}	Nm	1~5	1.5 倍額定輸出扭矩 1.5 Times of Rated Output Torque						
最大輸出扭矩 / Max. Output Torque 急停扭矩 / Emergency Stop Torque	T_{2NOT}	Nm	1~5	3 倍額定輸出扭矩 3 Times of Rated Output Torque						
額定輸入轉速 / Rated Input Speed	n_{1N}	rpm	1~5	3,000	3,000	3,000	2,500	2,500	2,000	2,000
最大輸入轉速 / Max. Input Speed	n_{1B}	rpm	1~5	6,000	6,000	5,500	4,500	3,500	3,000	3,000
背隙 / Backlash		arcmin	P0	-	≤ 3	≤ 3	≤ 3	≤ 3	≤ 3	≤ 3
			P1	≤ 6	≤ 6	≤ 6	≤ 6	≤ 6	≤ 6	≤ 6
			P2	≤ 9	≤ 9	≤ 9	≤ 9	≤ 9	≤ 9	≤ 9
容許徑向力 / Max. Radial Force 滾珠軸承 Ball Bearing	F_{2rB}	N	1~5	700	1,050	1,500	2,360	3,080	4,800	6,400
容許軸向力 / Max. Axial Force 滾珠軸承 Ball Bearing	F_{2aB}	N	1~5	350	525	750	1,180	1,540	2,400	3,200
容許徑向力 / Max. Radial Force 滾錐軸承 Taper Bearing	F_{2rB}	N	1~5	-	2,400	3,200	5,000	6,500	9,100	13,000
容許軸向力 / Max. Axial Force 滾錐軸承 Taper Bearing	F_{2aB}	N	1~5	-	1,200	1,600	2,500	3,250	4,550	6,500
使用壽命 / Service Life	L_H	hr	1~5	S5 周期運轉 : >30,000 (S1 連續運轉 : >15,000 hrs) S5 Cycle Operation: >30,000 (S1 Continuous Operation: >15,000 hrs)						
效 率 / Efficiency	η	%	1~5	94% ~ 98%						
使用溫度 / Operating Temperature		°C	1~5	-30°C ~ +100°C						
潤 滑 / Lubrication			1~5	全合成潤滑油 Synthetic Oil						
噪 音 值 / Noise Level		dB	1~5	≤ 65	≤ 67	≤ 71	≤ 73	≤ 74	≤ 75	≤ 77

轉動慣量 Mass Moments of Inertia (kgcm²)

速比 Ratio	65	75	90	110	140	170	210
1	0.51	1.79	4.93	12.5	36.8	85.9	287
2	0.44	0.95	2.78	7.41	15.6	39.3	123
3	0.43	0.78	2.34	6.18	10.9	28.5	84.1
4	0.43	0.72	2.18	5.71	9.19	24.5	69.9
5	0.43	0.69	2.10	5.48	8.32	22.6	62.7

Characteristic of ST Series

ST 系列產品特性

雙段減速機 2-Stage

規格 Model No.	代號	單位 Unit	速比 Ratio	65	75	90	110	140	170	210
額定輸出扭矩 / Rated Output Torque (Nominal output torque)	T_{2N}	Nm	10	24	42	68	150	330	544	1,220
			15	18	33	54	120	270	450	1,020
			20	13	28	48	100	224	376	860
			25	12	25	40	85	196	320	740
			30	18	33	54	120	270	450	1,020
			40	13	28	52	100	224	376	860
			50	12	25	40	85	196	320	740
最大加速扭矩 / Max. Acceleration Torque	T_{2B}	Nm	10~50	1.5 倍額定輸出扭矩 1.5 Times of Rated Output Torque						
最大輸出扭矩 / Max. Output Torque 急停扭矩 / Emergency Stop Torque	T_{2NOT}	Nm	10~50	3 倍額定輸出扭矩 3 Times of Rated Output Torque						
額定輸入轉速 / Rated Input Speed	n_{1N}	rpm	10~50	3,000	3,000	3,000	3,000	3,000	3,000	3,000
最大輸入轉速 / Max. Input Speed	n_{1B}	rpm	10~50	6,000	6,000	6,000	6,000	6,000	5,000	5,000
背隙 / Backlash		arcmin	P0	-	≤ 4	≤ 4	≤ 4	≤ 4	≤ 4	≤ 4
			P1	≤ 7	≤ 7	≤ 7	≤ 7	≤ 7	≤ 7	≤ 7
			P2	≤ 10	≤ 10	≤ 10	≤ 10	≤ 10	≤ 10	≤ 10
容許徑向力 / Max. Radial Force 滾珠軸承 Ball Bearing	F_{2rB}	N	1~5	700	1,050	1,500	2,360	3,080	4,800	6,400
容許軸向力 / Max. Axial Force 滾珠軸承 Ball Bearing	F_{2aB}	N	1~5	350	525	750	1,180	1,540	2,400	3,200
容許徑向力 / Max. Radial Force 滾錐軸承 Taper Bearing	F_{2rB}	N	1~5	-	2,400	3,200	5,000	6,500	9,100	13,000
容許軸向力 / Max. Axial Force 滾錐軸承 Taper Bearing	F_{2aB}	N	1~5	-	1,200	1,600	2,500	3,250	4,550	6,500
使用壽命 / Service Life	L_H	hr	10~50	S5 周期運轉 : >30,000 (S1 連續運轉 : >15,000 hrs) S5 Cycle Operation: >30,000 (S1 Continuous Operation: >15,000 hrs)						
效率 / Efficiency	η	%	10~50	90% ~ 94%						
使用溫度 / Operating Temperature		°C	10~50	-30°C ~ +100°C						
潤滑 / Lubrication			10~50	全合成潤滑油 Synthetic Oil						
噪音值 / Noise Level		dB	10~50	≤ 68	≤ 69	≤ 73	≤ 74	≤ 75	≤ 76	≤ 78

轉動慣量 Mass Moments of Inertia (kgcm²)

速比 Ratio	65	75	90	110	140	170	210
10	0.05	0.15	0.18	0.41	0.56	3.25	8.9
15	0.05	0.15	0.18	0.41	0.56	3.25	8.9
20	0.05	0.15	0.18	0.41	0.56	3.25	8.9
25	0.05	0.15	0.18	0.41	0.56	3.25	8.9
30	0.05	0.15	0.16	0.38	0.53	3.09	8.4
40	0.05	0.15	0.16	0.38	0.53	3.09	8.4
50	0.05	0.15	0.16	0.38	0.53	3.09	8.4

ST-FO series

RATIO : 1.2.3.4.5 (單段 1-Stage)

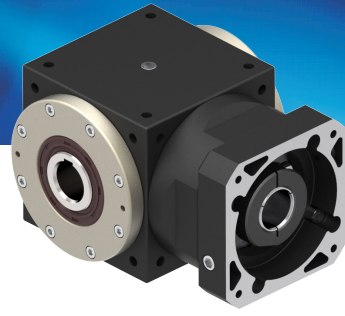

入力法蘭 - 出力中空軸

Input Flange - Hollow Output Shaft

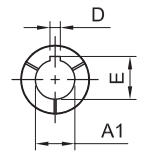
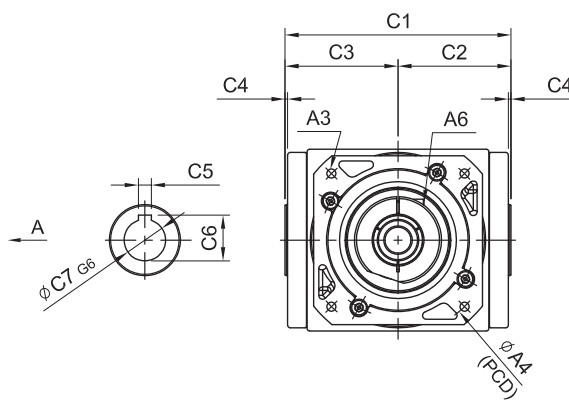
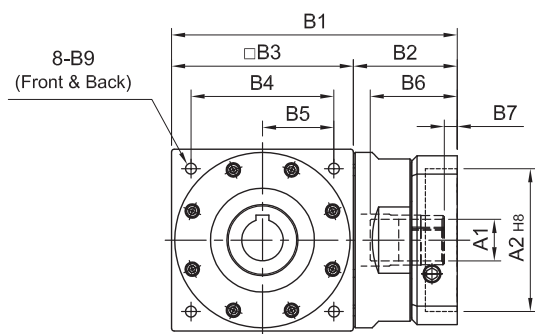
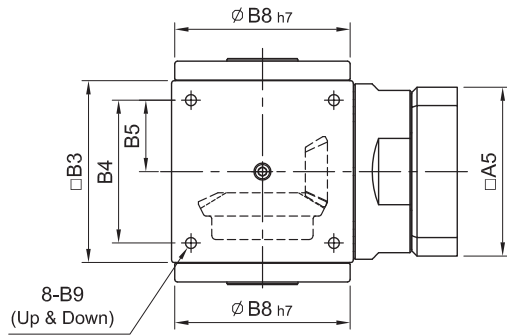

(入力孔$\phi 42$(含)以上)

A1	D	E
$\phi 42$	12	45.3
$\phi 48$	14	51.8
$\phi 55$	16	59.3

unit: mm

Model Code	65	65(1:1)	75	90	110	140	170	210	
A	A1	14	14	14	19、24	22、24	28、32	35	42、48、55
	A2	50、60、70	50、60、70	50、60、70	70、80、95、110	70、80、95、110	95、110、130	110、130、180	114.3、180、230
	A3	M4、M5、M6	M4、M5、M6	M4、M5、M6	M5、M6、M8	M5、M6、M8	M6、M8、M10	M8、M10、M12	M10、M12、M16
	A4	70、75、90	70、75、90	70、75、90	90、100、115、145	90、100、115、145	115、145、165	145、165、200	200、215、265
	A5	64、70、80	64、70、80	64、70、80	92、110、130	92、110、130	122、130、150	146、150、190	182、200、250
	A6	M5 x P0.8	M5 x P0.8	M5 x P0.8	M6 x P1.0	M6 x P1.0	M8 x P1.25	M10 x P1.5	M10 x P1.5
B	B1	110	110	115	148、162	177、191	224	274	357、359
	B2	45	45	40	58、72	67、81	84	104	147
	B3	65	65	75	90	110	140	170	210
	B4	52	52	60	72	88	110	134	170
	B5	26	26	30	36	44	55	67	85
	B6	36	36	36	51、65.5	51、65.5	68	84.5	117、119
	B7	7	7	7	9、23.5	9、23.5	10	9.5	14、16
	B8	62	64	73	88	106	135	164	205
	B9	M5 x P0.8	M5 x P0.8	M6 x P1.0	M6 x P1.0	M8 x P1.25	M10 x P1.5	M12 x P1.75	M16 x P2.0
C	C1	84	89	100	118	144	174	204	250
	C2	42	44.5	50	59	72	87	102	125
	C3	42	44.5	50	59	72	87	102	125
	C4	2	2	2	2	2	2	2	2
	C5	5	5	5	6	8	10	12	14
	C6	16.3	16.3	16.3	20.8	25.3	35.3	43.3	53.3
	C7	14	14	14	18	22	32	40	50
Weight	重量	1.7	1.7	2.4	4.3	7.1	14.9	24.5	46

ST-RO series

RATIO : 10.15.20.25.30.40.50 (雙段 2-Stage)

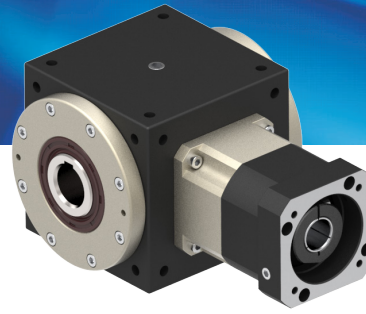

搭配行星減速機 - 出力中空軸

Fitted with Planetary Reducer - Hollow Output Shaft

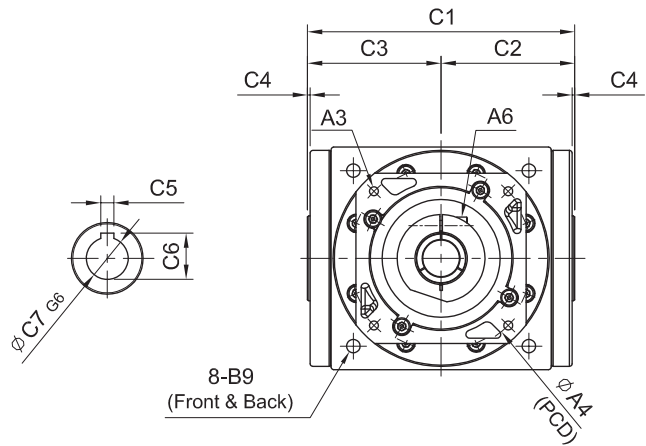
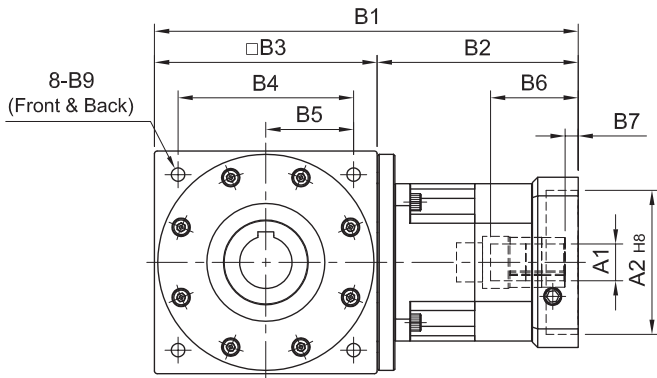
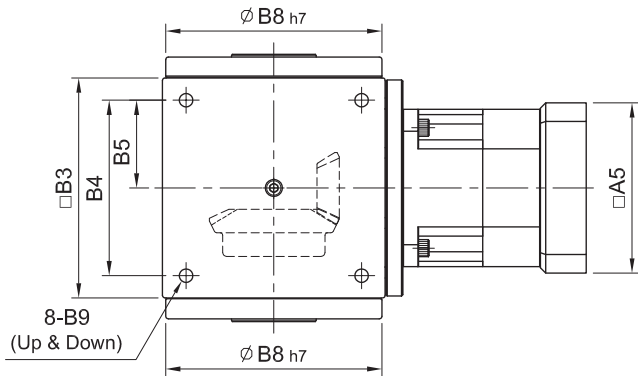

unit: mm

Model Code	65	75		90	110	140	170	210
	A	A1 8 · 11	8 · 11	14	14	(14) · 19	19 · 24	28 · 32
	A2 30 · 40 · 50	30 · 40 · 50	50 · 60 · 70	50 · 60 · 70	50 · 70 · 80 · 95	70 · 80 · 95 · 110	95 · 110 · 130	110 · 130 · 180
	A3 M3 · M4 · M5	M3 · M4 · M5	M4 · M5 · M6	M4 · M5 · M6	M5 · M6	M5 · M6 · M8	M6 · M8 · M10	M8 · M10 · M12
	A4 46 · 60 · 63	46 · 60 · 63	70 · 75 · 90	70 · 75 · 90	70 · 90 · 100 · 115	90 · 100 · 115 · 145	115 · 145 · 165	145 · 165 · 200
	A5 46 · 55	46 · 55	64 · 70 · 80	64 · 70 · 80	80 · 92 · 110	92 · 110 · 130	122 · 130 · 150	146 · 150 · 190
	A6 M4 x P0.7	M4 x P0.7	M5 x P0.8	M5 x P0.8	M5 x P0.8	M6 x P1.0	M8 x P1.25	M10 x P1.5
B	B1 132	137	149	165	(191) · 203	260	313	394
	B2 67	62	74	75	(81) · 93	120	143	184
	B3 65	75	75	90	110	140	170	210
	B4 52	60	60	72	88	110	134	170
	B5 26	30	30	36	44	55	67	85
	B6 26	26	33.5	33.5	(33.5) · 45.5	59	67	85
	B7 5	5	6	6	(6) · 10	9	10	10
	B8 62	73	73	88	106	135	164	205
	B9 M5 x P0.8	M6 x P1.0	M6 x P1.0	M6 x P1.0	M8 x P1.25	M10 x P1.5	M12 x P1.75	M16 x P2.0
C	C1 84	100	100	118	144	174	204	250
	C2 42	50	50	59	72	87	102	125
	C3 42	50	50	59	72	87	102	125
	C4 2	2	2	2	2	2	2	2
	C5 5	5	5	6	8	10	12	14
	C6 16.3	16.3	16.3	20.8	25.3	35.3	43.3	53.3
	C7 14	14	14	18	22	32	40	50
Weight 重量	1.9	3.6	3.4	4.8	8.5	14.2	24	52

ST-DO series

RATIO : 1.2.3.4.5 (單段 1-Stage)

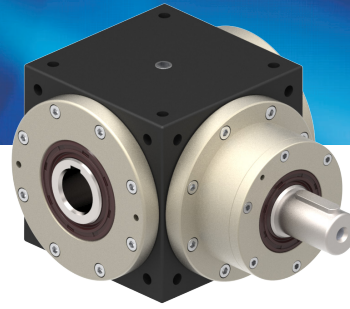

單入力軸心 - 出力中空軸

Single Input Shaft - Hollow Output Shaft

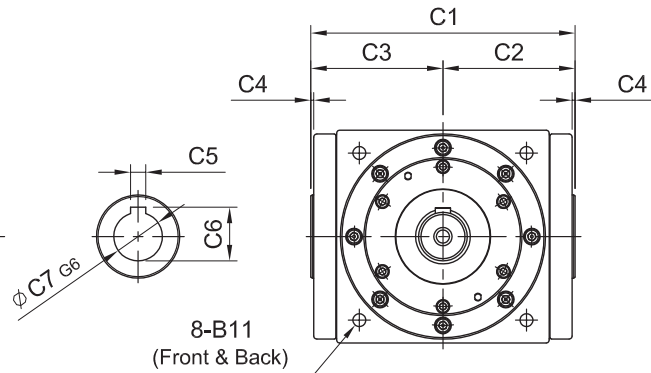
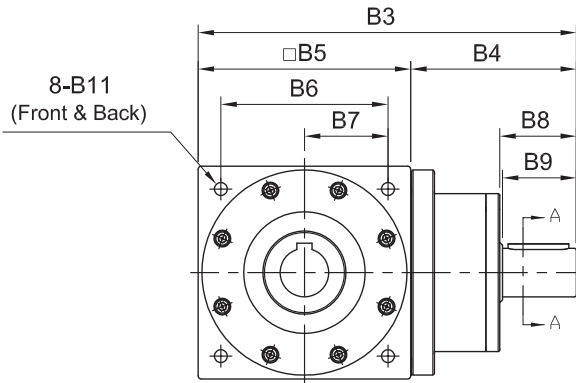
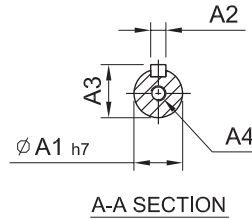
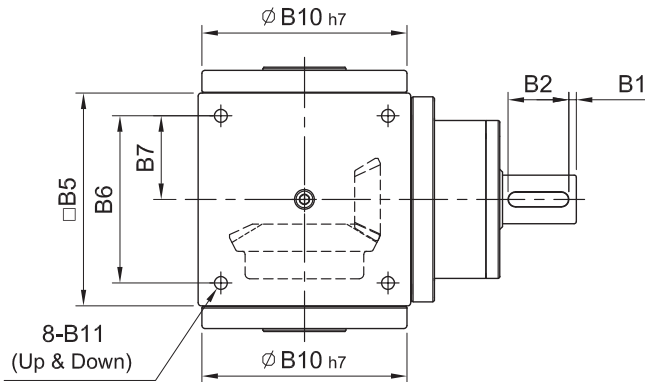

unit: mm

Model Code	65	65(1:1)	75	90	110	140	170	210	
	A								
A1	14	14	16	18	22	32	40	50	
A2	5	5	5	6	6	10	12	14	
A3	16	16	18	20.5	24.5	35	43	53.5	
A4	M5 x P0.8	M5 x P0.8	M5 x P0.8	M8 x P1.25	M8 x P1.25	M10 x P1.5	M12 x P1.75	M12 x P1.75	
B									
B1	2.5	2.5	2.5	5	5	5	5	5	
B2	15	15	25	25	30	40	50	65	
B3	127.5	127.5	143	168.5	207	250	300	375	
B4	62.5	62.5	67.5	78.5	97	110	130	165	
B5	65	65	75	90	110	140	170	210	
B6	52	52	60	72	88	110	134	170	
B7	26	26	30	36	44	55	67	85	
B8	22	22	32	38	43	53.5	64	77	
B9	20	20	30	35	40	50	60	75	
B10	62	64	73	88	106	135	164	205	
B11	M5 x P0.8	M5 x P0.8	M5 x P0.8	M6 x P1.0	M8 x P1.25	M10 x P1.5	M12 x P1.75	M16 x P2.0	
C									
C1	84	89	100	118	144	174	204	250	
C2	42	44.5	50	59	72	87	102	125	
C3	42	44.5	50	59	72	87	102	125	
C4	2	2	2	2	2	2	2	2	
C5	5	5	5	6	8	10	12	14	
C6	16.3	16.3	16.3	20.8	25.3	35.3	43.3	53.3	
C7	14	14	14	18	22	32	40	50	
Weight	重量	2.1	2.1	2.8	4.9	9	15.5	25	53

ST-YO series

RATIO : 1.2.3.4.5 (單段 1-Stage)

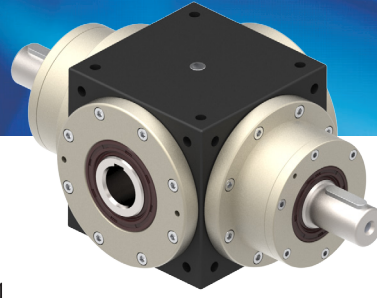

雙入力軸心 - 出力中空軸

Double Input Shaft - Hollow Output Shaft

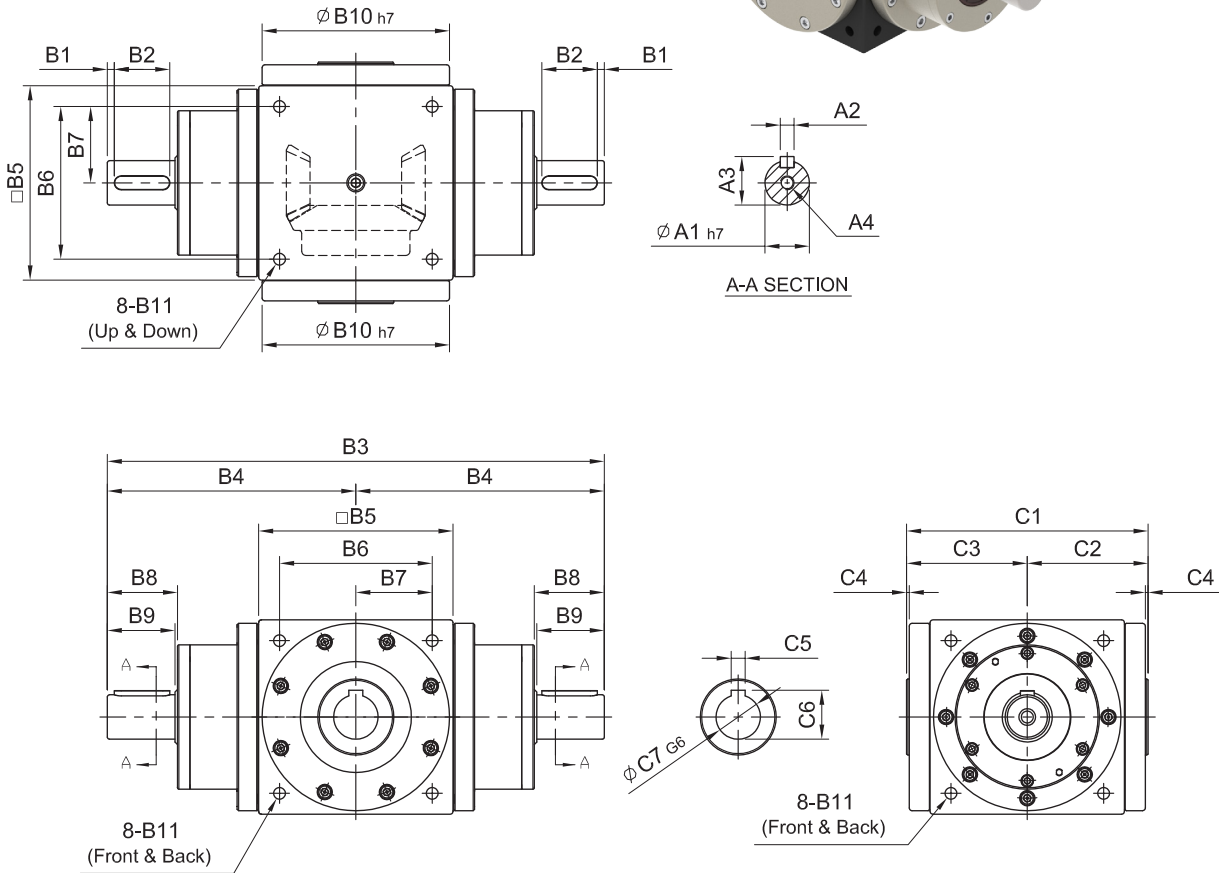

unit: mm

A	Model Code	65	65(1:1)	75	90	110	140	170	210
	A1	14	14	16	18	22	32	40	50
A2	5	5	5	6	6	10	12	14	
A3	16	16	18	20.5	24.5	35	43	53.5	
A4	M5 x P0.8	M5 x P0.8	M5 x P0.8	M8 x P1.25	M8 x P1.25	M10 x P1.5	M12 x P1.75	M12 x P1.75	
B	B1	2.5	2.5	2.5	5	5	5	5	5
	B2	15	15	25	25	30	40	50	65
	B3	190	190	210	247	304	360	430	540
	B4	95	95	105	123.5	152	180	215	270
	B5	65	65	75	90	110	140	170	210
	B6	52	52	60	72	88	110	134	170
	B7	26	26	30	36	44	55	67	85
	B8	22	22	32	38	43	53.5	64	77
	B9	20	20	30	35	40	50	60	75
	B10	62	64	73	88	106	135	164	205
C	B11	M5 x P0.8	M5 x P0.8	M6 x P1.0	M6 x P1.0	M8 x P1.25	M10 x P1.5	M12 x P1.75	M16 x P2.0
	C1	84	89	100	118	144	174	204	250
	C2	42	44.5	50	59	72	87	102	125
	C3	42	44.5	50	59	72	87	102	125
	C4	2	2	2	2	2	2	2	2
	C5	5	5	5	6	8	10	12	14
	C6	16.3	16.3	16.3	20.8	25.3	35.3	43.3	53.3
C7	14	14	14	18	22	32	40	50	
Weight	重量	2.85	2.85	3.6	6.2	11.5	18	28	57

ST

ST-FN series

RATIO : 1.2.3.4.5 (單段 1-Stage)

入力法蘭 - 單邊免鍵軸套

Input Flange - Single Clamping

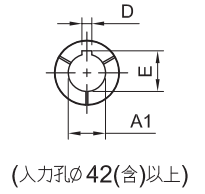
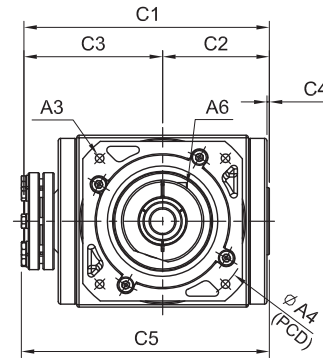
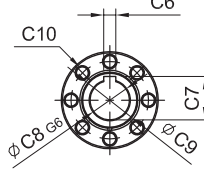
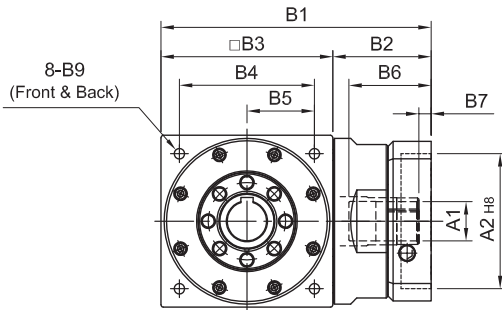
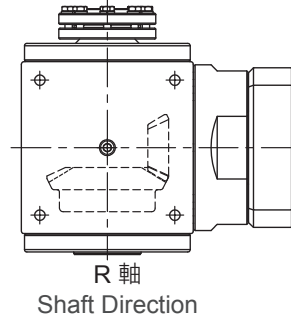
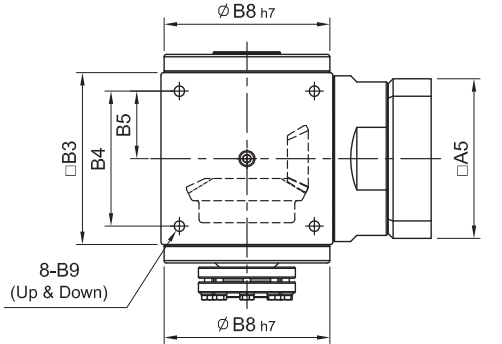
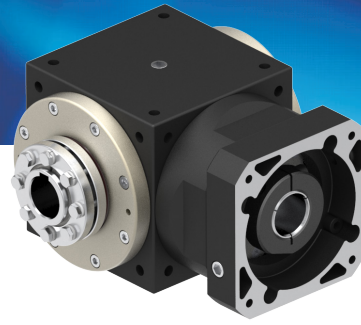

(入力孔 ϕ 42(含)以上)

A1	D	E
ϕ 42	12	45.3
ϕ 48	14	51.8
ϕ 55	16	59.3

unit: mm

Model Code	65	65(1:1)	75	90	110	140	170	210	
A	A1	14	14	14	19、24	22、24	28、32	35	42、48、55
	A2	50、60、70	50、60、70	50、60、70	70、80、95、110	70、80、95、110	95、110、130	110、130、180	114.3、180、230
	A3	M4、M5、M6	M4、M5、M6	M4、M5、M6	M5、M6、M8	M5、M6、M8	M6、M8、M10	M8、M10、M12	M10、M12、M16
	A4	70、75、90	70、75、90	70、75、90	90、100、115、145	90、100、115、145	115、145、165	145、165、200	200、215、265
	A5	64、70、80	64、70、80	64、70、80	92、110、130	92、110、130	122、130、150	146、150、190	182、200、250
	A6	M5 x P0.8	M5 x P0.8	M5 x P0.8	M6 x P1.0	M6 x P1.0	M8 x P1.25	M10 x P1.5	M10 x P1.5
B	B1	110	110	115	148、162	177、191	224	274	357、359
	B2	45	45	40	58、72	67、81	84	104	147
	B3	65	65	75	90	110	140	170	210
	B4	52	52	60	72	88	110	134	170
	B5	26	26	30	36	44	55	67	85
	B6	36	36	36	51、65.5	51、65.5	68	84.5	117
	B7	7	7	7	9、23.5	9、23.5	10	9.5	14、16
	B8	62	64	73	88	106	135	164	205
	B9	M5 x P0.8	M5 x P0.8	M6 x P1.0	M6 x P1.0	M8 x P1.25	M10 x P1.5	M12 x P1.75	M16 x P2.0
C	C1	104	109	120	138	169	202	240	285
	C2	42	44.5	50	59	72	87	102	125
	C3	62	64.5	70	79	97	115	138	160
	C4	2	2	2	2	2	2	2	2
	C5	110	113	124	142	171	202	242	288
	C6	5	5	5	6	8	10	12	14
	C7	16.3	16.3	16.3	20.8	25.3	35.3	43.3	53.3
	C8	14	14	14	18	22	32	40	50
	C9	22	22	22	28	34	44	52	65
	C10	6-M6	6-M6	6-M6	6-M6	8-M6	8-M6	8-M8	8-M8
Weight 重量	1.7	1.7	2.4	4.3	7.1	14.9	24.5	46	

ST-RN series

RATIO : 10.15.20.25.30.40.50 (雙段 2-Stage)

搭配行星減速機 - 單邊免鍵軸套

Fitted with Planetary Reducer - Single Clamping

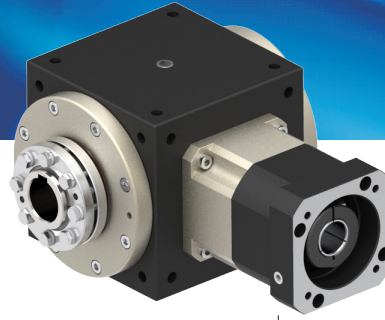

ST

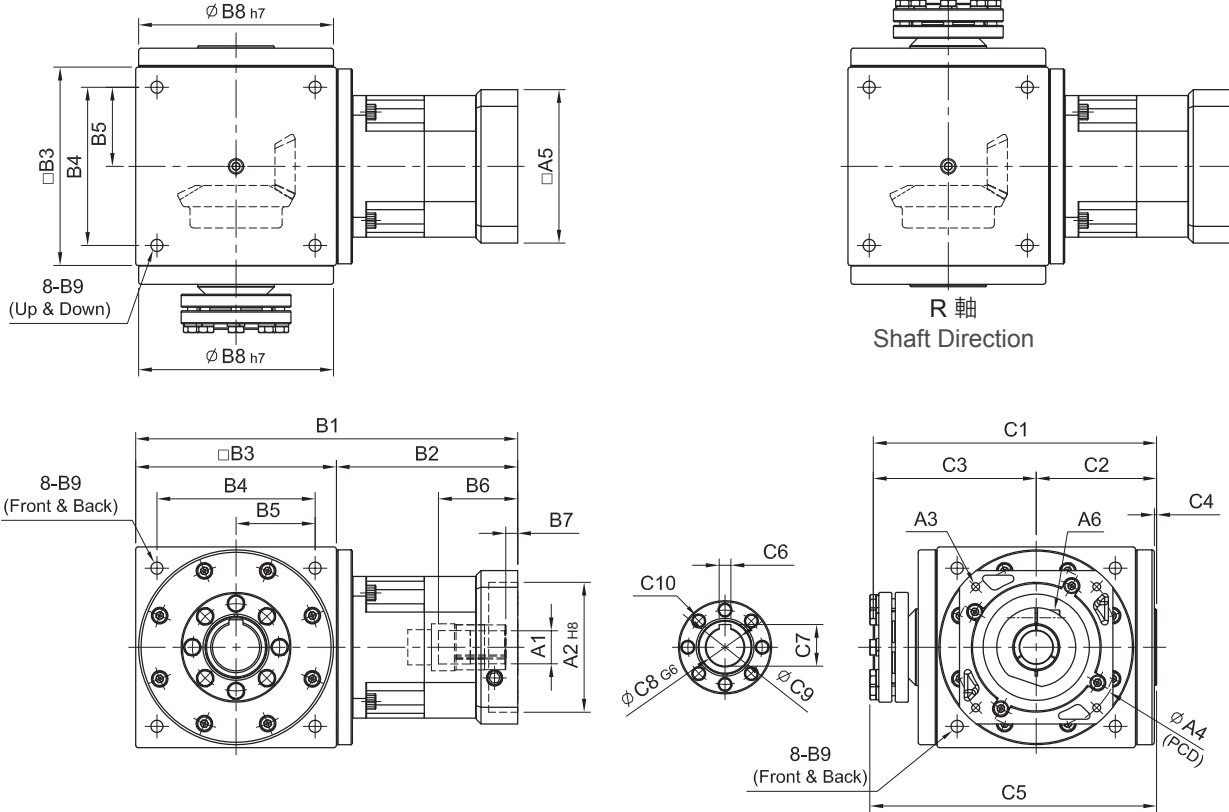

unit: mm

Model Code	65	75		90	110	140	170	210	
	A	A1 8·11	8·11	14	14	(14)·19	19·24	28·32	35
	A2 30·40·50	30·40·50	50·60·70	50·60·70	50·70·80·95	70·80·95·110	95·110·130	110·130·180	
	A3 M3·M4·M5	M3·M4·M5	M4·M5·M6	M4·M5·M6	M5·M6	M5·M6·M8	M6·M8·M10	M8·M10·M12	
	A4 46·60·63	46·60·63	70·75·90	70·75·90	70·90·100·115	90·100·115·145	115·145·165	145·165·200	
	A5 46·55	46·55	64·70·80	64·70·80	80·92·110	92·110·130	122·130·150	146·150·190	
	A6 M4 x P0.7	M4 x P0.7	M5 x P0.8	M5 x P0.8	M5 x P0.8	M6 x P1.0	M8 x P1.25	M10 x P1.5	
B	B1 132	137	149	165	(191)·203	260	313	394	
	B2 67	62	74	75	(81)·93	120	143	184	
	B3 65	75	75	90	110	140	170	210	
	B4 52	60	60	72	88	110	134	170	
	B5 26	30	30	36	44	55	67	85	
	B6 26	26	33.5	33.5	(33.5)·45.5	59	67	85	
	B7 5	5	6	6	(6)·10	9	10	10	
	B8 62	73	73	88	106	135	164	205	
	B9 M5 x P0.8	M6 x P1.0	M6 x P1.0	M6 x P1.0	M8 x P1.25	M10 x P1.5	M12 x P1.75	M16 x P2.0	
C	C1 104	120	120	138	169	200	240	285	
	C2 42	50	50	59	72	87	102	125	
	C3 62	70	70	79	97	113	138	160	
	C4 2	2	2	2	2	2	2	2	
	C5 118	124	124	142	171	202	242	288	
	C6 5	5	5	6	8	10	12	14	
	C7 16.3	16.3	16.3	20.8	25.3	35.3	43.3	53.3	
	C8 14	14	14	18	22	32	40	50	
	C9 22	22	22	28	34	44	52	65	
	C10 6-M6	6-M6	6-M6	6-M6	8-M6	8-M6	8-M8	8-M8	
Weight	重量	1.9	3.6	3.4	4.8	8.5	14.2	24	52

ST-DN series

RATIO : 1.2.3.4.5 (單段 1-Stage)

單入力軸心 - 單邊免鍵軸套

Single Input Shaft - Single Clamping

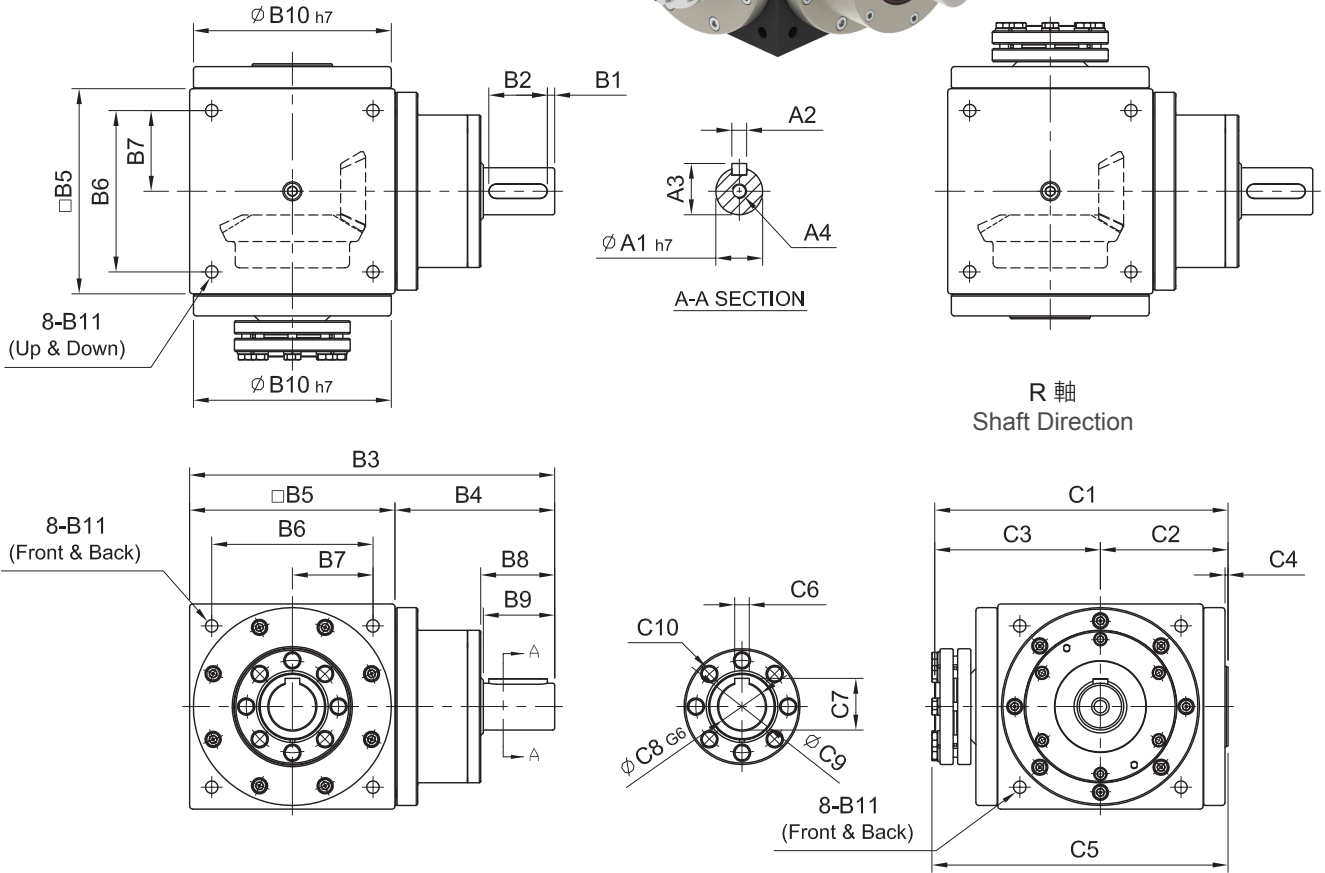
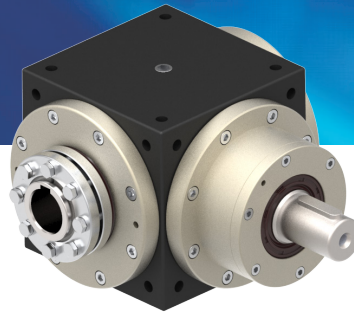

unit: mm

Model Code	65	65(1:1)	75	90	110	140	170	210	
	A	A1	14	14	16	18	22	32	40
	A2	5	5	5	6	6	10	12	14
	A3	16	16	18	20.5	24.5	35	43	53.5
	A4	M5 x P0.8	M5 x P0.8	M5 x P0.8	M8 x P1.25	M8 x P1.25	M10 x P1.5	M12 x P1.75	M12 x P1.75
B	B1	2.5	2.5	2.5	5	5	5	5	5
	B2	15	15	25	25	30	40	50	65
	B3	127.5	127.5	143	168.5	207	250	300	375
	B4	62.5	62.5	67.5	78.5	97	110	130	165
	B5	65	65	75	90	110	140	170	210
	B6	52	52	60	72	88	110	134	170
	B7	26	26	30	36	44	55	67	85
	B8	22	22	32	38	43	53.5	64	77
	B9	20	20	30	35	40	50	60	75
	B10	62	64	73	88	106	135	164	205
	B11	M5 x P0.8	M5 x P0.8	M6 x P1.0	M6 x P1.0	M8 x P1.25	M10 x P1.5	M12 x P1.75	M16 x P2.0
C	C1	104	109	120	138	169	202	240	285
	C2	42	44.5	50	59	72	87	102	125
	C3	62	64.5	70	79	97	115	138	160
	C4	2	2	2	2	2	2	2	2
	C5	110	113	124	142	171	202	242	288
	C6	5	5	5	6	8	10	12	14
	C7	16.3	16.3	16.3	20.8	25.3	35.3	43.3	53.3
	C8	14	14	14	18	22	32	40	50
	C9	22	22	22	28	34	44	52	65
	C10	6-M6	6-M6	6-M6	6-M6	8-M6	8-M6	8-M8	8-M8
Weight	重量	2.1	2.1	2.8	4.9	8.59	15.5	25	53

ST-YN series

RATIO : 1.2.3.4.5 (單段 1-Stage)

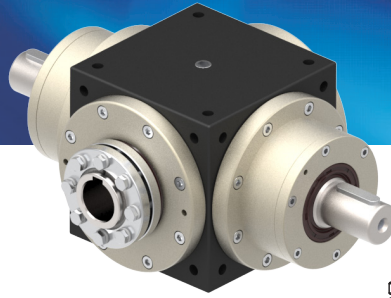

雙入力軸心 - 單邊免鍵軸套

Double Input Shaft - Single Clamping

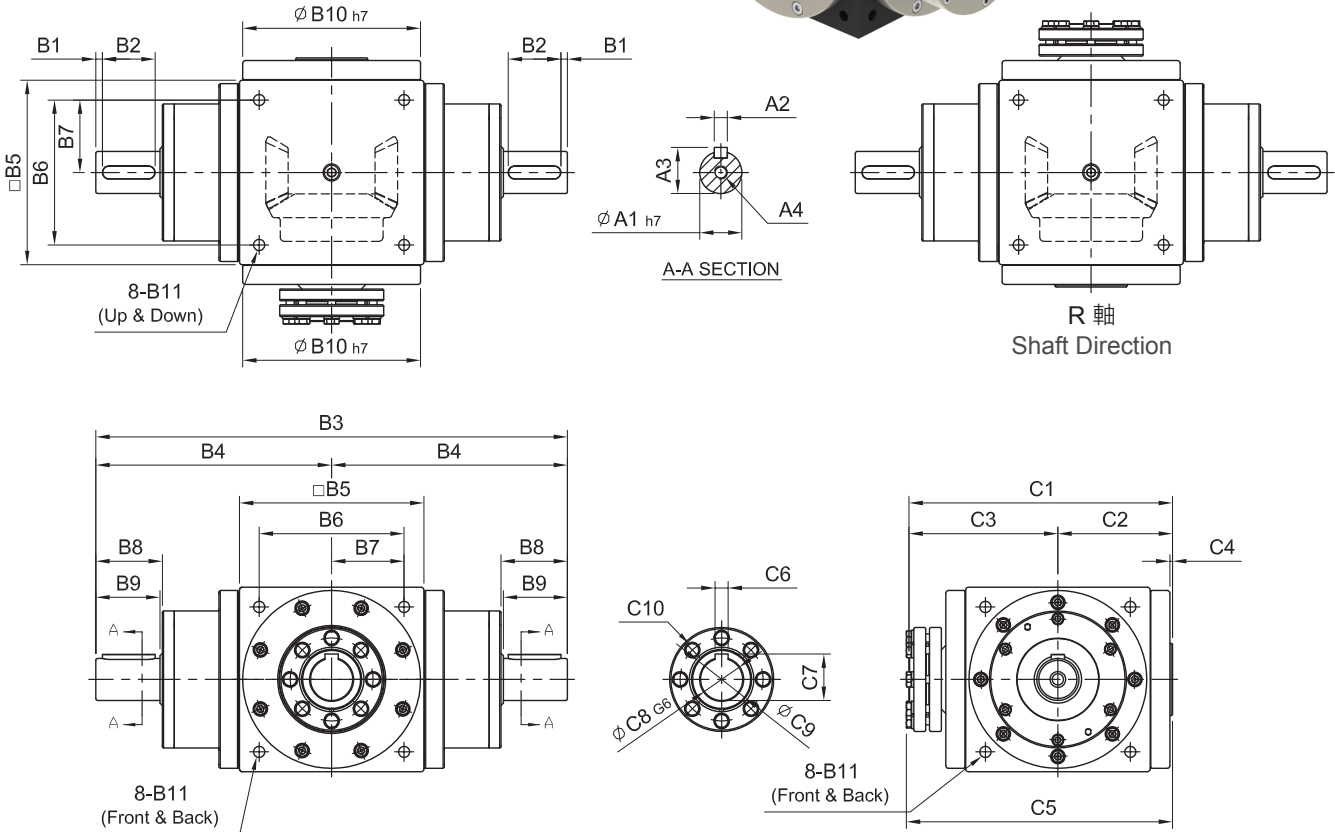

unit: mm

Model Code	65	65(1:1)	75	90	110	140	170	210	
	A	A1	14	14	16	18	22	32	40
	A2	5	5	5	6	6	10	12	14
	A3	16	16	18	20.5	24.5	35	43	53.5
	A4	M5 x P0.8	M5 x P0.8	M5 x P0.8	M8 x P1.25	M8 x P1.25	M10 x P1.5	M12 x P1.75	M12 x P1.75
B	B1	2.5	2.5	2.5	5	5	5	5	5
	B2	15	15	25	25	30	40	50	65
	B3	190	190	210	247	304	360	430	540
	B4	95	95	105	123.5	152	180	215	270
	B5	65	65	75	90	110	140	170	210
	B6	52	52	60	72	88	110	134	170
	B7	26	26	30	36	44	55	67	85
	B8	22	22	32	38	43	53.5	64	77
	B9	20	20	30	35	40	50	60	75
	B10	62	64	73	88	106	135	164	205
	B11	M5 x P0.8	M5 x P0.8	M6 x P1.0	M6 x P1.0	M8 x P1.25	M10 x P1.5	M12 x P1.75	M16 x P2.0
C	C1	104	109	120	138	169	200	240	285
	C2	42	44.5	50	59	72	87	102	125
	C3	62	64.5	70	79	97	113	138	160
	C4	2	2	2	2	2	2	2	2
	C5	110	113	124	142	171	202	242	288
	C6	5	5	5	6	8	10	12	14
	C7	16.3	16.3	16.3	20.8	25.3	35.3	43.3	53.3
	C8	14	14	14	18	22	32	40	50
	C9	22	22	22	28	34	44	52	65
	C10	6-M6	6-M6	6-M6	6-M6	8-M6	8-M6	8-M8	8-M8
Weight	重量	2.85	2.85	3.6	6.2	11.5	18	28	57

ST

ST-FM series

RATIO : 1.2.3.4.5 (單段 1-Stage)

入力法蘭 - 雙邊免鍵軸套

Input Flange - Double Clamping

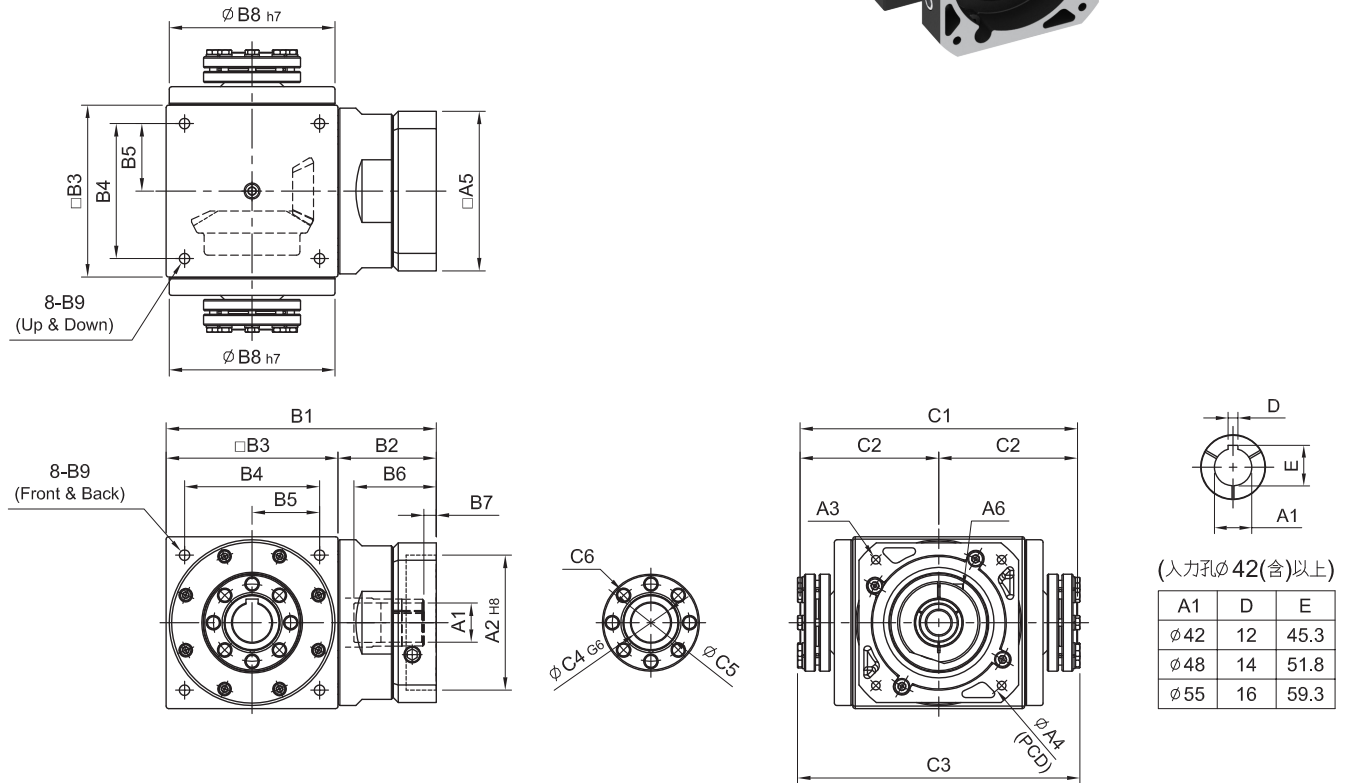
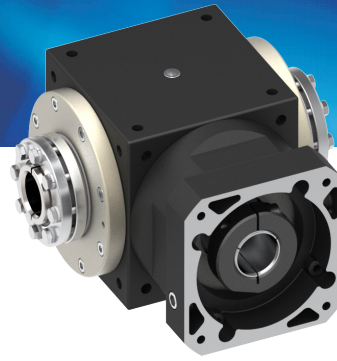

(入力孔 ϕ 42(含)以上)

A1	D	E
ϕ 42	12	45.3
ϕ 48	14	51.8
ϕ 55	16	59.3

unit: mm

Model Code	65	65(1:1)	75	90	110	140	170	210	
A	A1	14	14	14	19、24	22、24	28、32	35	42、48、55
	A2	50、60、70	50、60、70	50、60、70	70、80、95、110	70、80、95、110	95、110、130	110、130、180	114.3、180、230
	A3	M4、M5、M6	M4、M5、M6	M4、M5、M6	M5、M6、M8	M5、M6、M8	M6、M8、M10	M8、M10、M12	M10、M12、M16
	A4	70、75、90	70、75、90	70、75、90	90、100、115、145	90、100、115、145	115、145、165	145、165、200	200、215、265
	A5	64、70、80	64、70、80	64、70、80	92、110、130	92、110、130	122、130、150	146、150、190	182、200、250
	A6	M5 x P0.8	M5 x P0.8	M5 x P0.8	M6 x P1.0	M6 x P1.0	M8 x P1.25	M10 x P1.5	M10 x P1.5
B	B1	110	110	115	148、162	177、191	224	274	357、359
	B2	45	45	40	58、72	67、81	84	104	147
	B3	65	65	75	90	110	140	170	210
	B4	52	52	60	72	88	110	134	170
	B5	26	26	30	36	44	55	67	85
	B6	36	36	37	51、65.5	51、65.5	68	84.5	117
	B7	7	7	7	9、23.5	9、23.5	10	9.5	14、16
	B8	62	64	73	88	106	135	164	205
	B9	M5 x P0.8	M5 x P0.8	M6 x P1.0	M6 x P1.0	M8 x P1.25	M10 x P1.5	M12 x P1.75	M16 x P2.0
C	C1	124	129	140	158	194	230	276	320
	C2	62	64.5	70	79	97	115	138	160
	C3	136	138	150	166	198	232	280	327
	C4	14	14	14	18	22	32	40	50
	C5	22	22	22	28	34	44	52	65
	C6	6-M6	6-M6	6-M6	6-M6	8-M6	8-M6	8-M8	8-M8
Weight	重量	1.7	1.7	2.4	4.3	7.1	14.9	24.5	46

ST-RM series

RATIO : 10.15.20.25.30.40.50 (雙段 2-Stage)

搭配行星減速機 - 雙邊免鍵軸套

Fitted with Planetary Reducer - Double Clamping

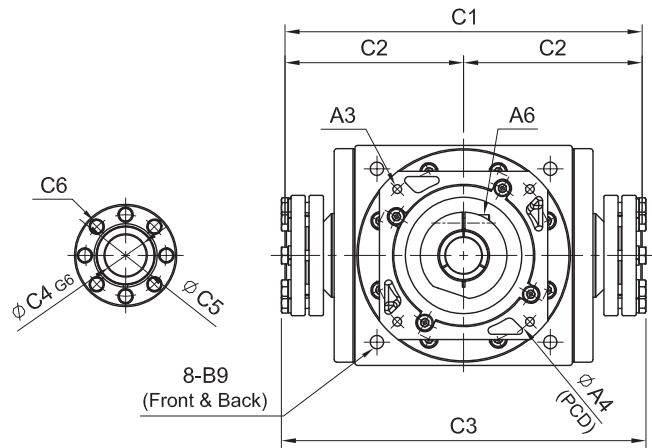
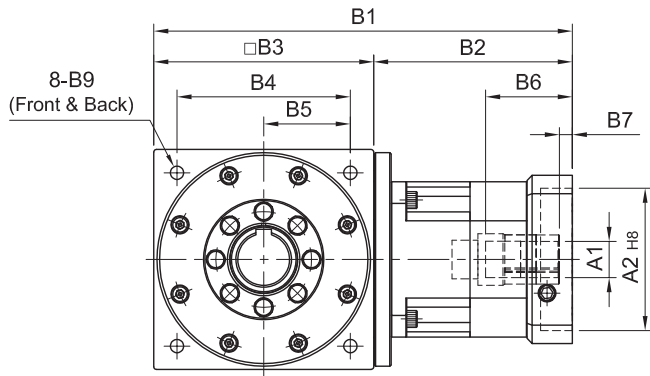
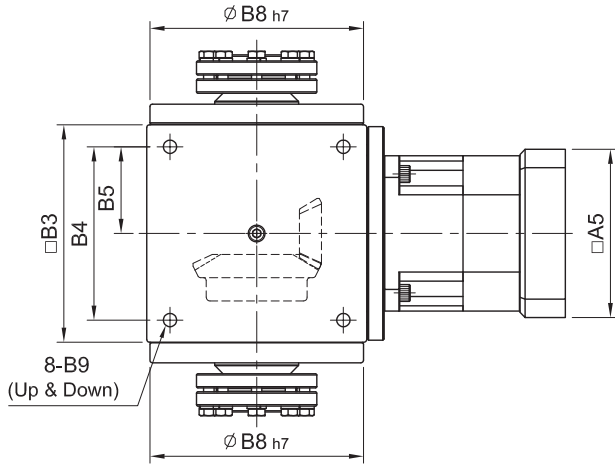
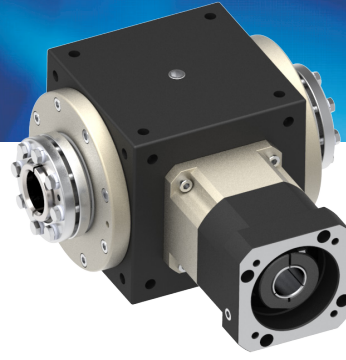

unit: mm

Model Code	65	75	90	110	140	170	210	
	A	A1: 8 · 11	A1: 8 · 11	A1: 14	A1: 14	A1: (14) · 19	A1: 19 · 24	A1: 28 · 32
	A2: 30 · 40 · 50	A2: 30 · 40 · 50	A2: 50 · 60 · 70	A2: 50 · 60 · 70	A2: 50 · 70 · 80 · 95	A2: 70 · 80 · 95 · 110	A2: 95 · 110 · 130	A2: 110 · 130 · 180
	A3: M3 · M4 · M5	A3: M3 · M4 · M5	A3: M4 · M5 · M6	A3: M4 · M5 · M6	A3: M5 · M6	A3: M5 · M6 · M8	A3: M6 · M8 · M10	A3: M8 · M10 · M12
	A4: 46 · 60 · 63	A4: 46 · 60 · 63	A4: 70 · 75 · 90	A4: 70 · 75 · 90	A4: 70 · 90 · 100 · 115	A4: 90 · 100 · 115 · 145	A4: 115 · 145 · 165	A4: 145 · 165 · 200
	A5: 46 · 55	A5: 46 · 55	A5: 64 · 70 · 80	A5: 64 · 70 · 80	A5: 80 · 92 · 110	A5: 92 · 110 · 130	A5: 122 · 130 · 150	A5: 146 · 150 · 190
	A6: M4 x P0.7	A6: M4 x P0.7	A6: M5 x P0.8	A6: M5 x P0.8	A6: M5 x P0.8	A6: M6 x P1.0	A6: M8 x P1.25	A6: M10 x P1.5
B	B1: 132	B1: 137	B1: 149	B1: 165	B1: (191) · 203	B1: 260	B1: 313	B1: 394
	B2: 67	B2: 62	B2: 62	B2: 75	B2: (81) · 93	B2: 120	B2: 143	B2: 184
	B3: 65	B3: 75	B3: 75	B3: 90	B3: 110	B3: 140	B3: 170	B3: 210
	B4: 52	B4: 60	B4: 60	B4: 72	B4: 88	B4: 110	B4: 134	B4: 170
	B5: 26	B5: 30	B5: 30	B5: 36	B5: 44	B5: 55	B5: 67	B5: 85
	B6: 26	B6: 26	B6: 26	B6: 33.5	B6: (33.5) · 45.5	B6: 59	B6: 67	B6: 85
	B7: 5	B7: 5	B7: 5	B7: 6	B7: (6) · 10	B7: 9	B7: 10	B7: 10
	B8: 62	B8: 73	B8: 73	B8: 88	B8: 106	B8: 135	B8: 164	B8: 205
	B9: M5 x P0.8	B9: M6 x P1.0	B9: M6 x P1.0	B9: M6 x P1.0	B9: M8 x P1.25	B9: M10 x P1.5	B9: M12 x P1.75	B9: M16 x P2.0
C	C1: 124	C1: 140	C1: 140	C1: 158	C1: 194	C1: 230	C1: 276	C1: 320
	C2: 62	C2: 70	C2: 70	C2: 79	C2: 97	C2: 115	C2: 138	C2: 160
	C3: 136	C3: 150	C3: 150	C3: 166	C3: 198	C3: 232	C3: 280	C3: 327
	C4: 14	C4: 14	C4: 14	C4: 18	C4: 22	C4: 32	C4: 40	C4: 50
	C5: 22	C5: 22	C5: 22	C5: 28	C5: 34	C5: 44	C5: 52	C5: 65
	C6: 6-M6	C6: 6-M6	C6: 6-M6	C6: 6-M6	C6: 8-M6	C6: 8-M6	C6: 8-M8	C6: 8-M8
Weight	重量: 1.9	重量: 3.6	重量: 3.4	重量: 4.8	重量: 8.5	重量: 14.2	重量: 24	重量: 52

ST-DM series

RATIO : 1.2.3.4.5 (單段 1-Stage)

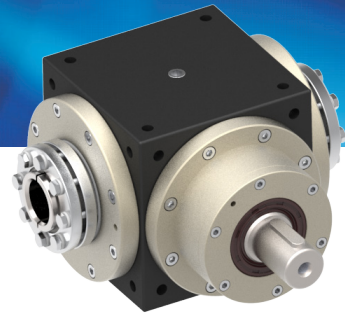

單入力軸心 - 雙邊免鍵軸套

Single Input Shaft - Double Clamping

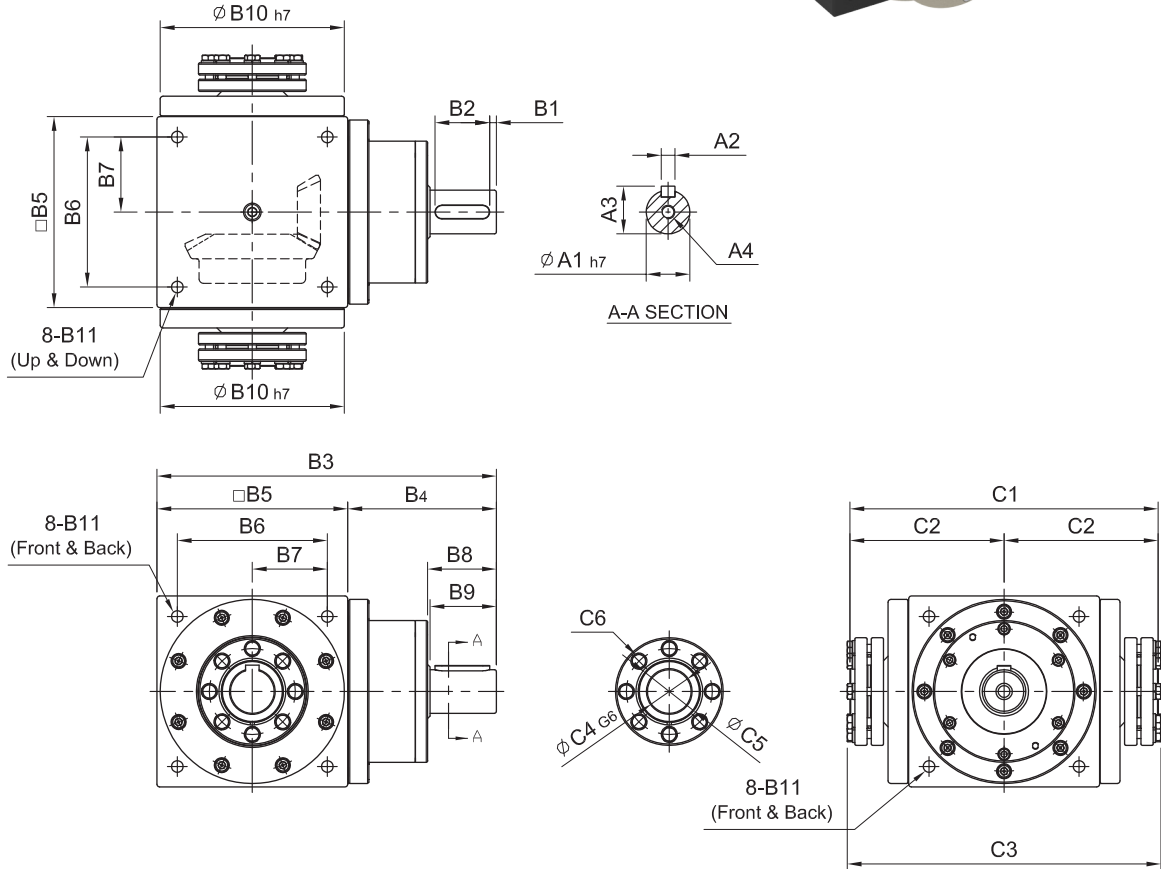

unit: mm

Model Code	65	65(1:1)	75	90	110	140	170	210	
	A								
A1	14	14	16	18	22	32	40	50	
A2	5	5	5	6	6	10	12	14	
A3	16	16	18	20.5	24.5	35	43	53.5	
A4	M5 x P0.8	M5 x P0.8	M5 x P0.8	M8 x P1.25	M8 x P1.25	M10 x P1.5	M12 x P1.75	M12 x P1.75	
B									
B1	2.5	2.5	2.5	5	5	5	5	5	
B2	15	15	25	25	30	40	50	65	
B3	127.5	127.5	143	168.5	207	250	300	375	
B4	62.5	62.5	67.5	78.5	97	110	130	165	
B5	65	65	75	90	110	140	170	210	
B6	52	52	60	72	88	110	134	170	
B7	26	26	30	36	44	55	67	85	
B8	22	22	32	38	43	53.5	64	77	
B9	20	20	30	35	40	50	60	75	
B10	62	64	73	88	106	135	164	205	
B11	M5 x P0.8	M5 x P0.8	M6 x P1.0	M6 x P1.0	M8 x P1.25	M10 x P1.5	M12 x P1.75	M16 x P2.0	
C									
C1	124	129	140	158	194	230	276	320	
C2	62	64.5	70	79	97	115	138	160	
C3	136	138	150	166	198	232	280	327	
C4	14	14	14	18	22	32	40	50	
C5	22	22	22	28	34	44	52	65	
C6	6-M6	6-M6	6-M6	6-M6	8-M6	8-M6	8-M8	8-M8	
Weight	重量								
		2.1	2.1	2.8	4.9	8.59	15.5	25	53

ST-YM series

RATIO : 1.2.3.4.5 (單段 1-Stage)

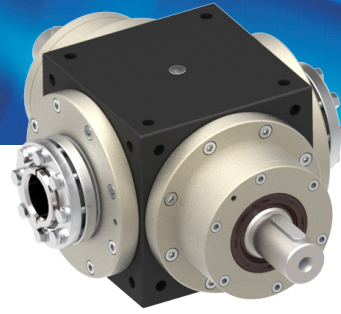

雙入力軸心 - 雙邊免鍵軸套

Double Input Shaft - Double Clamping

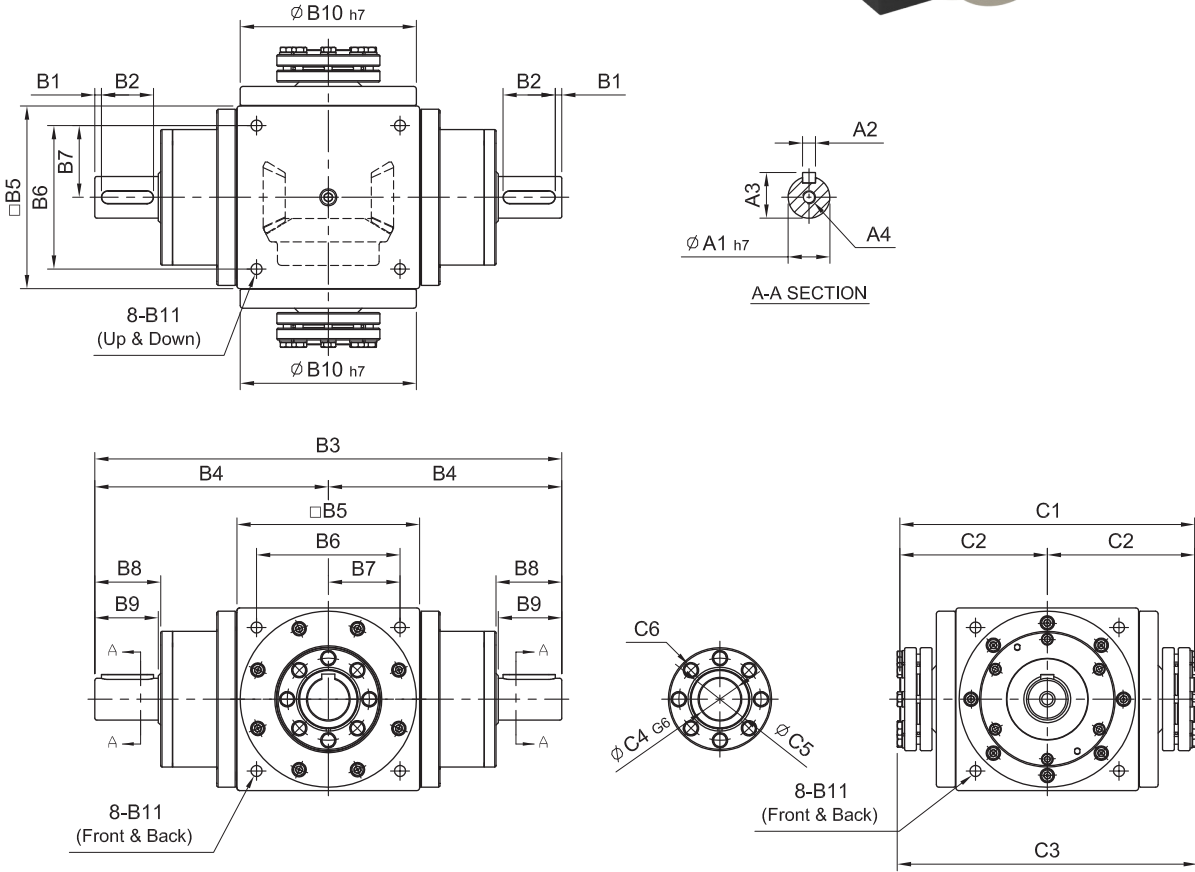

unit: mm

Model Code	65	65(1:1)	75	90	110	140	170	210	
	A								
A1	14	14	16	18	22	32	40	50	
A2	5	5	5	6	6	10	12	14	
A3	16	16	18	20.5	24.5	35	43	53.5	
A4	M5 x P0.8	M5 x P0.8	M5 x P0.8	M8 x P1.25	M8 x P1.25	M10 x P1.5	M12 x P1.75	M12 x P1.75	
B									
B1	2.5	2.5	2.5	5	5	5	5	5	
B2	15	15	25	25	30	40	50	65	
B3	190	190	210	247	304	360	430	540	
B4	95	95	95	123.5	152	180	215	270	
B5	65	65	75	90	110	140	170	210	
B6	52	52	60	72	88	110	134	170	
B7	26	26	30	36	44	55	67	85	
B8	22	22	32	38	43	53.5	64	77	
B9	20	20	30	35	40	50	60	75	
B10	62	64	73	88	106	135	164	205	
B11	M5 x P0.8	M5 x P0.8	M6 x P1.0	M6 x P1.0	M8 x P1.25	M10 x P1.5	M12 x P1.75	M16 x P2.0	
C									
C1	124	129	140	158	194	230	276	320	
C2	62	64.5	70	79	97	115	138	160	
C3	136	138	150	166	198	232	280	327	
C4	14	14	14	18	22	32	40	50	
C5	22	22	22	28	34	44	52	65	
C6	6-M6	6-M6	6-M6	6-M6	8-M6	8-M6	8-M8	8-M8	
Weight	重量	2.85	2.85	3.6	6.2	11.5	18	28	57

ST-FS series

RATIO : 1.2.3.4.5 (單段 1-Stage)

入力法蘭 - 單出力軸心

Input Flange - Single Output Shaft

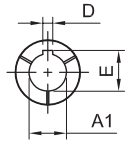
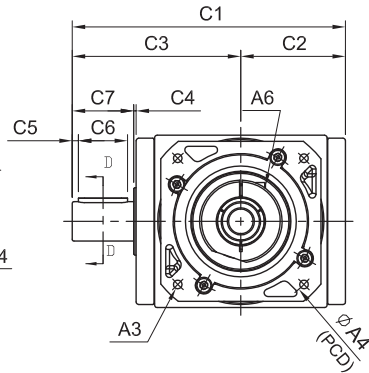
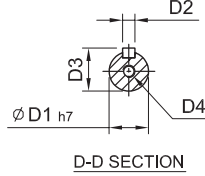
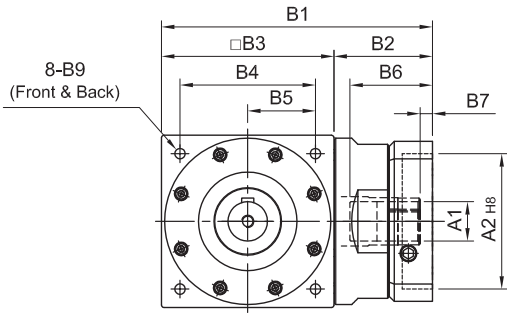
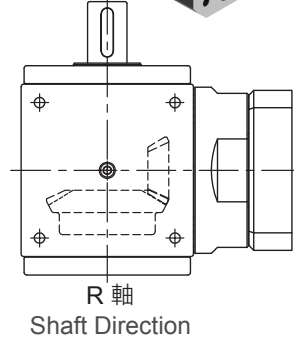
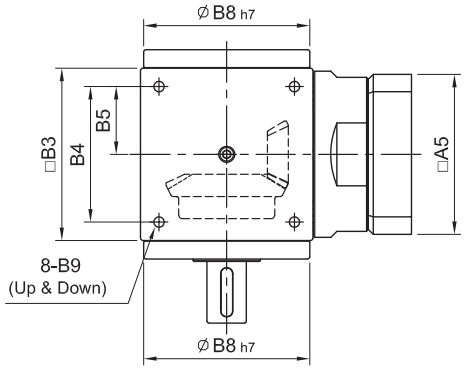
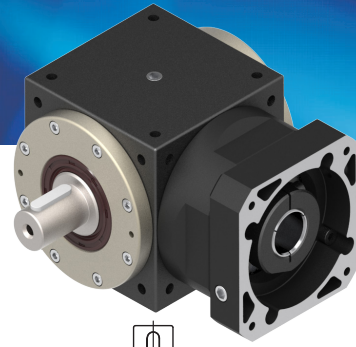

(入力孔$\phi 42$(含)以上)

A1	D	E
$\phi 42$	12	45.3
$\phi 48$	14	51.8
$\phi 55$	16	59.3

unit: mm

	Model Code	65	65(1:1)	75	90	110	140	170	210
		A	A1	14	14	14	19·24	22·24	28·32
	A2	50·60·70	50·60·70	50·60·70	70·80·95·110	70·80·95·110	95,110,130	110,130,180	114.3·180·230
	A3	M4·M5·M6	M4·M5·M6	M4·M5·M6	M5·M6·M8	M5·M6·M8	M6·M8·M10	M8·M10·M12	M10·M12·M16
	A4	70·75·90	70·75·90	70·75·90	90·100·115·145	90·100·115·145	115·145·165	145·165·200	200·215·265
	A5	64·70·80	64·70·80	64·70·80	92·110·130	92·110·130	122·130·150	146·150·190	182·200·250
	A6	M5 x P0.8	M5 x P0.8	M5 x P0.8	M6 x P1.0	M6 x P1.0	M8 x P1.25	M10 x P1.5	M10 x P1.5
B	B1	110	110	115	148·162	177·191	224	274	357·359
	B2	45	45	40	58·72	67·81	84	104	147
	B3	65	65	75	90	110	140	170	210
	B4	52	52	60	72	88	110	134	170
	B5	26	26	30	36	44	55	67	85
	B6	36	36	36	51·65.5	51·65.5	67	84.5	117
	B7	7	7	7	9·23.5	9·23.5	10	9.5	14·16
	B8	62	64	73	88	106	135	164	205
	B9	M5 x P0.8	M5 x P0.8	M6 x P1.0	M6 x P1.0	M8 x P1.25	M10 x P1.5	M12 x P1.75	M16 x P2.0
C	C1	102	107	128	151	182	222	262	323
	C2	40	42.5	48	57	70	85	100	123
	C3	62	64.5	80	94	112	137	162	200
	C4	2	2	2	2	2	2	2	2
	C5	2.5	2.5	2.5	5	5	5	5	5
	C6	15	15	25	25	30	40	50	65
	C7	20	20	30	35	40	50	60	75
D	D1	14	14	16	18	22	32	40	50
	D2	5	5	5	6	6	10	12	14
	D3	16	16	18	20.5	24.5	35	43	53.5
	D4	M5 x P0.8	M5 x P0.8	M5 x P0.8	M5 x P0.8	M5 x P0.8	M10 x P1.5	M12 x P1.75	M12 x P1.75
Weight	重量	1.7	1.7	2.4	4.3	7.1	14.9	24.5	46

ST-RS series

RATIO : 10.15.20.25.30.40.50 (雙段 2-Stage)

搭配行星減速機 - 單出力軸心

Fitted with Planetary Reducer - Single Output Shaft

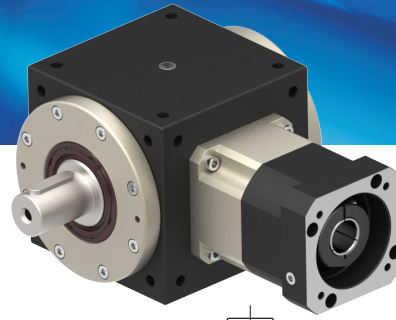

ST

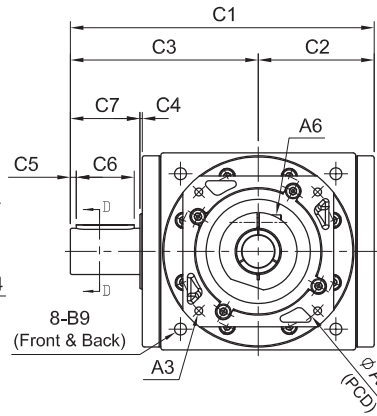
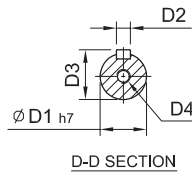
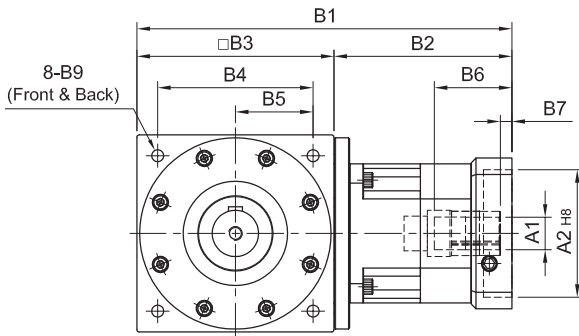
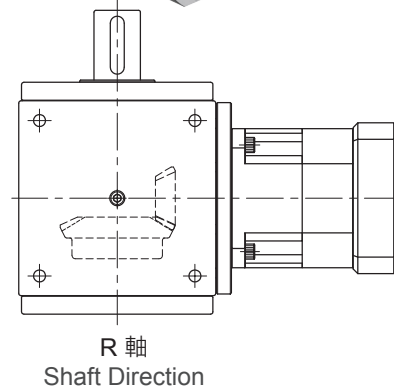
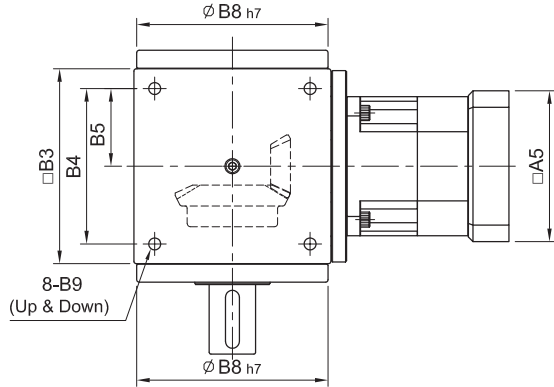

unit: mm

	Model Code	65	75	90	110	140	170	210	
		A	A1	8 · 11	8 · 11	14	14	14 · 19	19 · 24
	A2	30 · 40 · 50	30 · 40 · 50	50 · 60 · 70	50 · 60 · 70	50 · 70 · 80 · 95	70 · 80 · 95 · 110	95 · 110 · 130	110 · 130 · 180
	A3	M3 · M4 · M5	M3 · M4 · M5	M4 · M5 · M6	M4 · M5 · M6	M5 · M6	M5 · M6 · M8	M6 · M8 · M10	M8 · M10 · M12
	A4	46 · 60 · 63	46 · 60 · 63	70 · 75 · 90	70 · 75 · 90	70 · 90 · 100 · 115	90 · 100 · 115 · 145	115 · 145 · 165	145 · 165 · 200
	A5	46 · 55	46 · 55	64 · 70 · 80	64 · 70 · 80	80 · 92 · 110	92 · 110 · 130	122 · 130 · 150	146 · 150 · 190
	A6	M4 x P0.7	M4 x P0.7	M5 x P0.8	M5 x P0.8	M5 x P0.8	M6 x P1.0	M8 x P1.25	M10 x P1.5
B	B1	132	137	149	165	191	260	313	394
	B2	67	62	62	75	81	120	143	184
	B3	65	75	75	90	110	140	170	210
	B4	52	60	60	72	88	110	134	170
	B5	26	30	30	36	44	55	67	85
	B6	26	26	26	33.5	33.5	59	67	85
	B7	5	5	5	6	6	9	10	10
	B8	62	73	73	88	106	135	164	205
	B9	M5 x P0.8	M6 x P1.0	M6 x P1.0	M6 x P1.0	M8 x P1.25	M10 x P1.5	M12 x P1.75	M16 x P2.0
C	C1	102	128	128	151	182	222	262	323
	C2	40	48	48	57	70	85	100	123
	C3	62	80	80	94	112	137	162	200
	C4	2	2	2	2	2	2	2	2
	C5	2.5	2.5	2.5	5	5	5	5	5
	C6	15	25	25	25	30	40	50	65
	C7	20	30	30	35	40	50	60	75
D	D1	14	16	16	18	22	32	40	50
	D2	5	5	5	6	6	10	12	14
	D3	16	18	18	20.5	24.5	35	43	53.5
	D4	M5 x P0.8	M5 x P0.8	M5 x P0.8	M5 x P0.8	M5 x P0.8	M10 x P1.5	M12 x P1.75	M12 x P1.75
Weight	重量	1.9	3.6	3.4	4.8	8.5	14.2	24	52

ST-DS series

RATIO : 1.2.3.4.5 (單段 1-Stage)

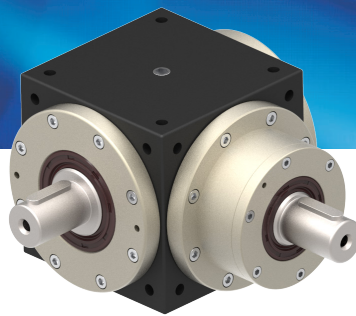

單入力軸心 - 單出力軸心

Single Input Shaft - Single Output Shaft

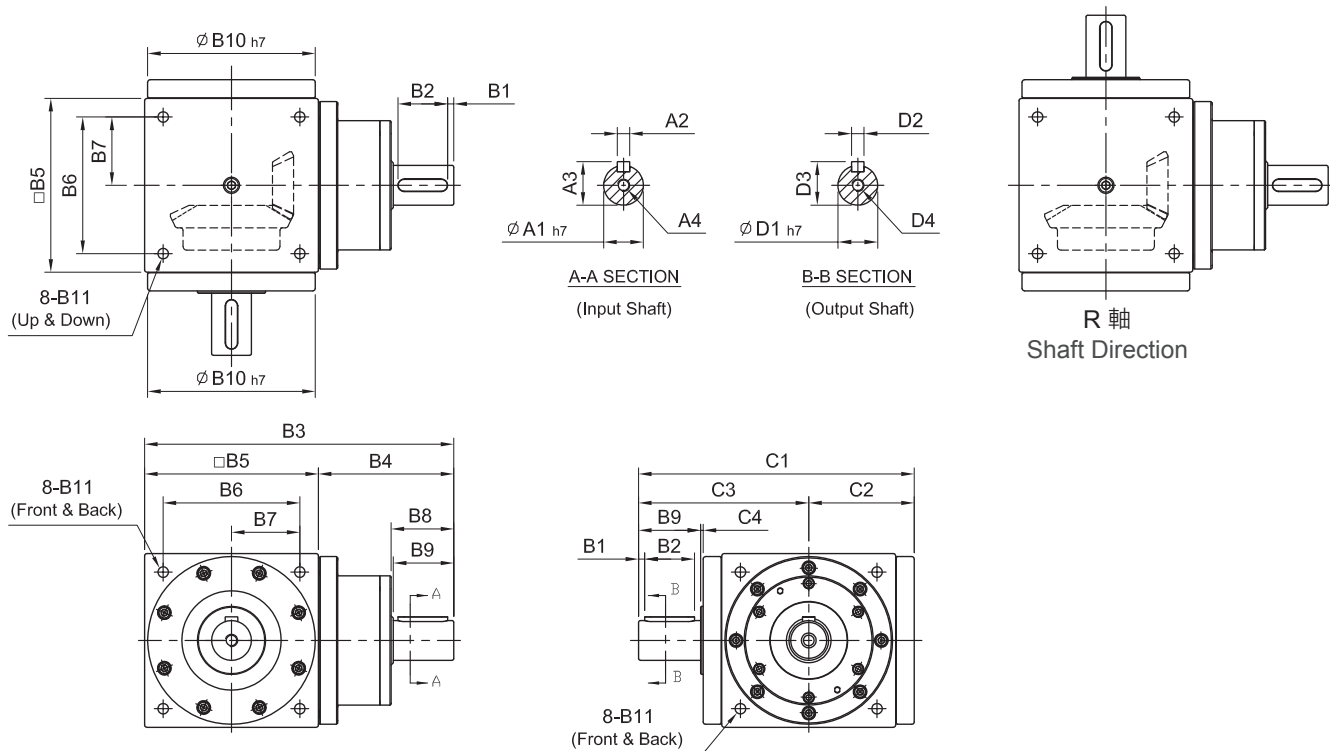

unit: mm

Model Code	unit: mm								
	65	65(1:1)	75	90	110	140	170	210	
A	A1	14	14	16	18	22	32	40	50
	A2	5	5	5	6	6	10	12	14
	A3	16	16	18	20.5	24.5	35	43	53.5
	A4	M5 x P0.8	M5 x P0.8	M5 x P0.8	M8 x P1.25	M8 x P1.25	M10 x P1.5	M12 x P1.75	M12 x P1.75
B	B1	2.5	2.5	2.5	5	5	5	5	5
	B2	15	15	25	25	30	40	50	65
	B3	127.5	127.5	143	168.5	207	250	300	375
	B4	62.5	62.5	67.5	78.5	97	110	130	165
	B5	65	65	75	90	110	140	170	210
	B6	52	52	60	72	88	110	134	170
	B7	26	26	30	36	44	55	67	85
	B8	22	22	32	38	43	53.5	64	77
	B9	20	20	30	35	40	50	60	75
	B10	62	64	73	88	106	135	164	205
	B11	M5 x P0.8	M5 x P0.8	M6 x P1.0	M6 x P1.0	M8 x P1.25	M10 x P1.5	M12 x P1.75	M16 x P2.0
C	C1	102	107	128	151	182	222	262	323
	C2	40	42.5	48	57	70	85	100	123
	C3	62	64.5	80	94	112	137	162	200
	C4	2	2	2	2	2	2	2	2
D	D1	14	14	16	18	22	32	40	50
	D2	5	5	5	6	6	10	12	14
	D3	16	16	18	20.5	24.5	35	43	53.5
	D4	M5 x P0.8	M5 x P0.8	M5 x P0.8	M5 x P0.8	M5 x P0.8	M10 x P1.5	M12 x P1.75	M12 x P1.75
Weight	重量	2.1	2.1	2.8	4.9	8.59	15.5	25	53

ST-YS series

RATIO : 1.2.3.4.5 (單段 1-Stage)

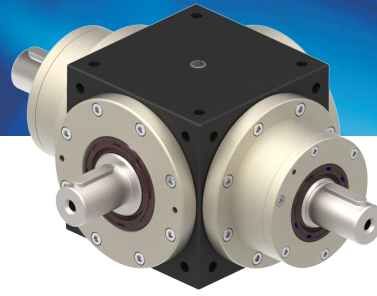

雙入力軸心 - 單出力軸心

Double Input Shaft - Single Output Shaft

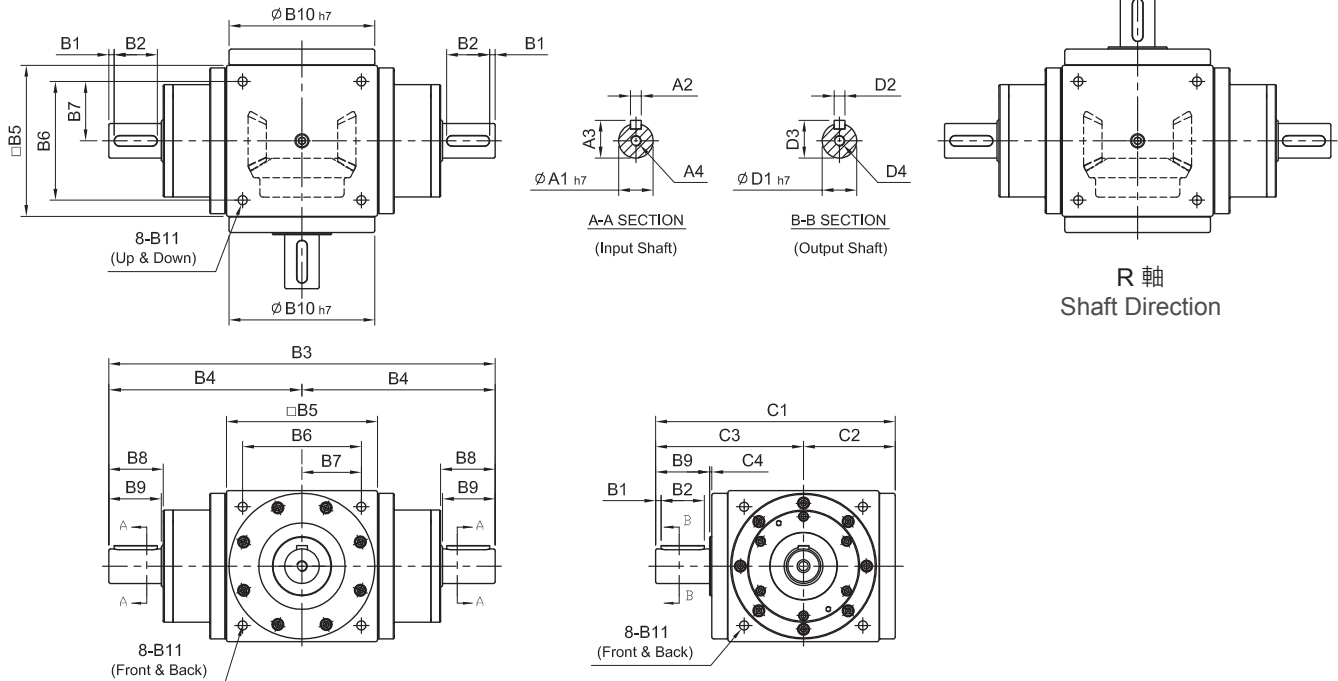

unit: mm

A	Model Code	65	65(1:1)	75	90	110	140	170	210
	A1	14	14	16	18	22	32	40	50
A2	5	5	5	6	6	10	12	14	
A3	16	16	18	20.5	24.5	35	43	53.5	
A4	M5 x P0.8	M5 x P0.8	M5 x P0.8	M8 x P1.25	M8 x P1.25	M10 x P1.5	M12 x P1.75	M12 x P1.75	
B	B1	2.5	2.5	2.5	5	5	5	5	5
	B2	15	15	25	25	30	40	50	65
	B3	190	190	210	247	304	360	430	540
	B4	95	95	105	123.5	152	180	215	270
	B5	65	65	75	90	110	140	170	210
	B6	52	52	60	72	88	110	134	170
	B7	26	26	30	36	44	55	67	85
	B8	22	22	32	38	43	53.5	64	77
	B9	20	20	30	35	40	50	60	75
	B10	62	64	73	88	106	135	164	205
C	B11	M5 x P0.8	M5 x P0.8	M6 x P1.0	M6 x P1.0	M8 x P1.25	M10 x P1.5	M12 x P1.75	M16 x P2.0
	C1	102	107	128	151	182	222	262	323
	C2	40	42.5	48	57	70	85	100	123
	C3	62	64.5	80	94	112	137	162	200
D	C4	2	2	2	2	2	2	2	2
	D1	14	14	16	18	22	32	40	50
	D2	5	5	5	6	6	10	12	14
	D3	16	16	18	20.5	24.5	35	43	53.5
Weight	D4	M5 x P0.8	M5 x P0.8	M5 x P0.8	M5 x P0.8	M5 x P0.8	M10 x P1.5	M12 x P1.75	M12 x P1.75
	重量	2.85	2.85	3.6	6.2	11.5	18	28	57

ST-FV series

RATIO : 1.2.3.4.5 (單段 1-Stage)

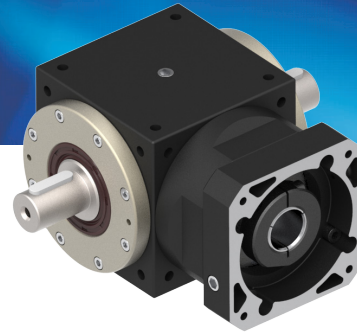

入力法蘭 - 雙出力軸心

Input Flange - Double Output Shaft

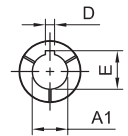
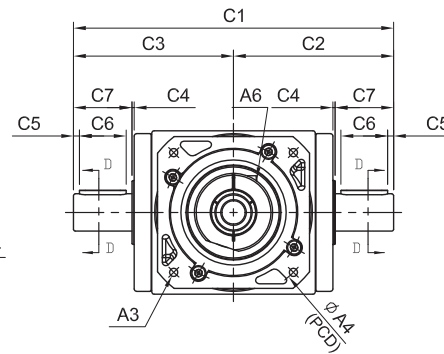
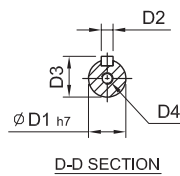
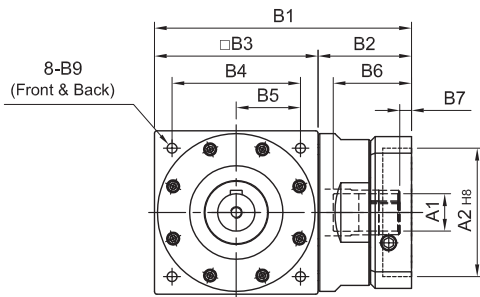
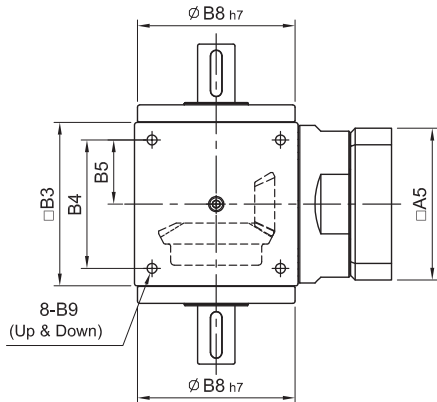

(入力孔 ϕ 42(含)以上)

A1	D	E
ϕ 42	12	45.3
ϕ 48	14	51.8
ϕ 55	16	59.3

unit: mm

Model Code	65	65(1:1)	75	90	110	140	170	210
	A	A1: 14 A2: 50·60·70 A3: M4·M5·M6 A4: 70·75·90 A5: 64·70·80 A6: M5 x P0.8	A1: 14 A2: 50·60·70 A3: M4·M5·M6 A4: 70·75·90 A5: 64·70·80 A6: M5 x P0.8	A1: 14 A2: 50·60·70 A3: M4·M5·M6 A4: 70·75·90 A5: 64·70·80 A6: M5 x P0.8	A1: 19·24 A2: 70·80·95·110 A3: M5·M6·M8 A4: 90·100·115·145 A5: 92·110·130 A6: M6 x P1.0	A1: 22·24 A2: 70·80·95·110 A3: M5·M6·M8 A4: 90·100·115·145 A5: 92·110·130 A6: M6 x P1.0	A1: 28·32 A2: 95·110·130 A3: M6·M8·M10 A4: 115·145·165 A5: 122·130·150 A6: M8 x P1.25	A1: 35 A2: 110·130·180 A3: M8·M10·M120 A4: 145·165·200 A5: 146·150·190 A6: M10 x P1.5
B	B1: 110 B2: 45 B3: 65 B4: 52 B5: 26 B6: 36 B7: 7 B8: 62 B9: M5 x P0.8	B1: 110 B2: 45 B3: 65 B4: 52 B5: 26 B6: 36 B7: 7 B8: 64 B9: M5 x P0.8	B1: 115 B2: 40 B3: 75 B4: 60 B5: 30 B6: 36 B7: 7 B8: 73 B9: M6 x P1.0	B1: 148·162 B2: 58·72 B3: 90 B4: 72 B5: 36 B6: 51·65.5 B7: 9·23.5 B8: 88 B9: M6 x P1.0	B1: 177·191 B2: 67·81 B3: 110 B4: 88 B5: 44 B6: 51·65.5 B7: 9·23.5 B8: 106 B9: M8 x P1.25	B1: 224 B2: 84 B3: 140 B4: 110 B5: 55 B6: 67 B7: 10 B8: 135 B9: M10 x P1.5	B1: 274 B2: 104 B3: 170 B4: 134 B5: 67 B6: 84.5 B7: 9.5 B8: 164 B9: M12 x P1.75	B1: 357·359 B2: 147 B3: 210 B4: 170 B5: 85 B6: 117 B7: 14·16 B8: 205 B9: M16 x P2.0
C	C1: 124 C2: 62 C3: 62 C4: 2 C5: 2.5 C6: 15 C7: 20	C1: 129 C2: 64.5 C3: 64.5 C4: 2 C5: 2.5 C6: 15 C7: 20	C1: 160 C2: 80 C3: 80 C4: 2 C5: 2.5 C6: 25 C7: 30	C1: 188 C2: 94 C3: 94 C4: 2 C5: 5 C6: 25 C7: 35	C1: 224 C2: 112 C3: 112 C4: 2 C5: 5 C6: 30 C7: 40	C1: 274 C2: 137 C3: 137 C4: 2 C5: 5 C6: 40 C7: 50	C1: 324 C2: 162 C3: 162 C4: 2 C5: 5 C6: 50 C7: 60	C1: 400 C2: 200 C3: 200 C4: 2 C5: 5 C6: 65 C7: 75
D	D1: 14 D2: 5 D3: 16 D4: M5 x P0.8	D1: 14 D2: 5 D3: 16 D4: M5 x P0.8	D1: 16 D2: 5 D3: 18 D4: M5 x P0.8	D1: 18 D2: 6 D3: 20.5 D4: M5 x P0.8	D1: 22 D2: 6 D3: 24.5 D4: M5 x P0.8	D1: 32 D2: 10 D3: 35 D4: M10 x P1.5	D1: 40 D2: 12 D3: 43 D4: M12 x P1.75	D1: 50 D2: 14 D3: 53.5 D4: M12 x P1.75
Weight	重量: 1.7	重量: 1.7	重量: 2.4	重量: 4.3	重量: 7.1	重量: 14.9	重量: 24.5	重量: 46

ST-RV series

RATIO : 10.15.20.25.30.40.50 (雙段 2-Stage)

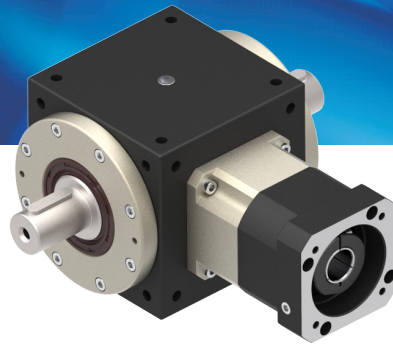

搭配行星減速機 - 雙出力軸心

Fitted with Planetary Reducer - Double Output Shaft

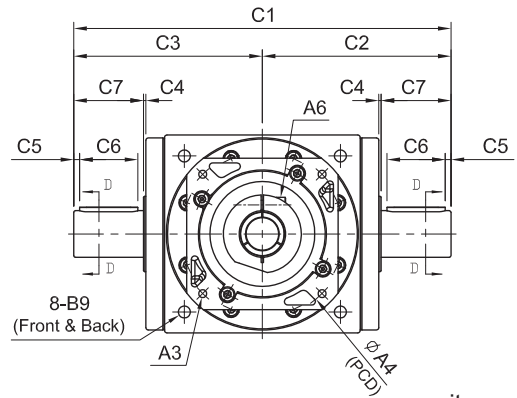
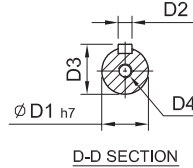
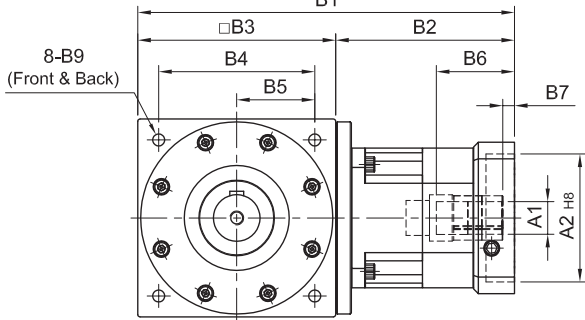
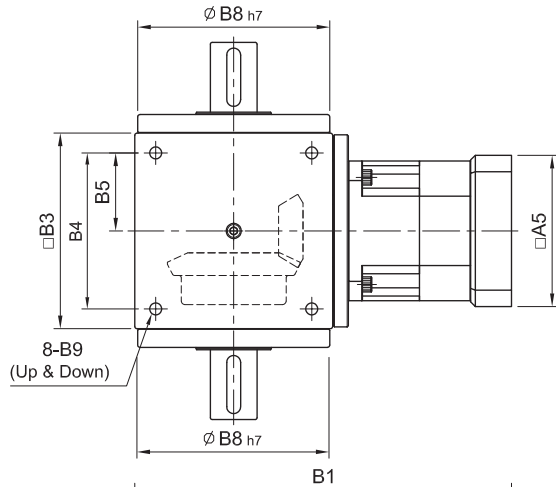

unit: mm

Model Code	65	75	90	110	140	170	210	
	A	A1: 8 · 11 A2: 30 · 40 · 50 A3: M3 · M4 · M5 A4: 46 · 60 · 63 A5: 46 · 55 A6: M4 x P0.7	A1: 8 · 11 A2: 30 · 40 · 50 A3: M3 · M4 · M5 A4: 46 · 60 · 63 A5: 46 · 55 A6: M4 x P0.7	A1: 14 A2: 50 · 60 · 70 A3: M4 · M5 · M6 A4: 70 · 75 · 90 A5: 64 · 70 · 80 A6: M5 x P0.8	A1: 14 A2: 50 · 60 · 70 A3: M4 · M5 · M6 A4: 70 · 75 · 90 A5: 64 · 70 · 80 A6: M5 x P0.8	A1: 14 · 19 A2: 50 · 70 · 80 · 95 A3: M5 · M6 A4: 70 · 90 · 100 · 115 A5: 80 · 92 · 110 A6: M5 x P0.8	A1: 19 · 24 A2: 70 · 80 · 95 · 110 A3: M5 · M6 · M8 A4: 90 · 100 · 115 · 145 A5: 92 · 110 · 130 A6: M6 x P1.0	A1: 28 · 32 A2: 95 · 110 · 130 A3: M6 · M8 · M10 A4: 115 · 145 · 165 A5: 122 · 130 · 150 A6: M8 x P1.25
B	B1: 132 B2: 67 B3: 65 B4: 52 B5: 26 B6: 26 B7: 5 B8: 62 B9: M5 x P0.8	B1: 137 B2: 62 B3: 75 B4: 60 B5: 30 B6: 26 B7: 5 B8: 73 B9: M6 x P1.0	B1: 149 B2: 62 B3: 75 B4: 60 B5: 30 B6: 26 B7: 5 B8: 73 B9: M6 x P1.0	B1: 165 B2: 75 B3: 90 B4: 72 B5: 36 B6: 33.5 B7: 6 B8: 88 B9: M6 x P1.0	B1: 191 B2: 81 B3: 110 B4: 88 B5: 44 B6: 33.5 B7: 6 B8: 106 B9: M8 x P1.25	B1: 260 B2: 120 B3: 140 B4: 110 B5: 55 B6: 59 B7: 9 B8: 135 B9: M10 x P1.5	B1: 313 B2: 143 B3: 170 B4: 134 B5: 67 B6: 67 B7: 10 B8: 164 B9: M12 x P1.75	B1: 394 B2: 184 B3: 210 B4: 170 B5: 85 B6: 85 B7: 10 B8: 205 B9: M16 x P2.0
C	C1: 124 C2: 62 C3: 62 C4: 2 C5: 2.5 C6: 15 C7: 20	C1: 160 C2: 80 C3: 80 C4: 2 C5: 2.5 C6: 25 C7: 30	C1: 160 C2: 80 C3: 80 C4: 2 C5: 2.5 C6: 25 C7: 30	C1: 188 C2: 94 C3: 94 C4: 2 C5: 5 C6: 25 C7: 35	C1: 224 C2: 112 C3: 112 C4: 2 C5: 5 C6: 30 C7: 40	C1: 274 C2: 137 C3: 137 C4: 2 C5: 5 C6: 40 C7: 50	C1: 324 C2: 162 C3: 162 C4: 2 C5: 5 C6: 50 C7: 60	C1: 400 C2: 200 C3: 200 C4: 2 C5: 5 C6: 65 C7: 75
D	D1: 14 D2: 5 D3: 16 D4: M5 x P0.8	D1: 16 D2: 5 D3: 18 D4: M5 x P0.8	D1: 16 D2: 5 D3: 18 D4: M5 x P0.8	D1: 18 D2: 6 D3: 20.5 D4: M5 x P0.8	D1: 22 D2: 6 D3: 24.5 D4: M5 x P0.8	D1: 32 D2: 10 D3: 35 D4: M10 x P1.5	D1: 40 D2: 12 D3: 43 D4: M12 x P1.75	D1: 50 D2: 14 D3: 53.5 D4: M12 x P1.75
Weight	1.9	3.6	3.4	4.8	8.5	14.2	24	52

ST-DV series

RATIO : 1.2.3.4.5 (單段 1-Stage)

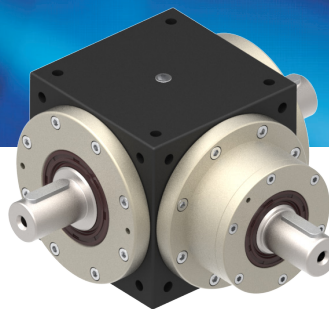

單入力軸心 - 雙出力軸心

Single Input Shaft - Double Output Shaft

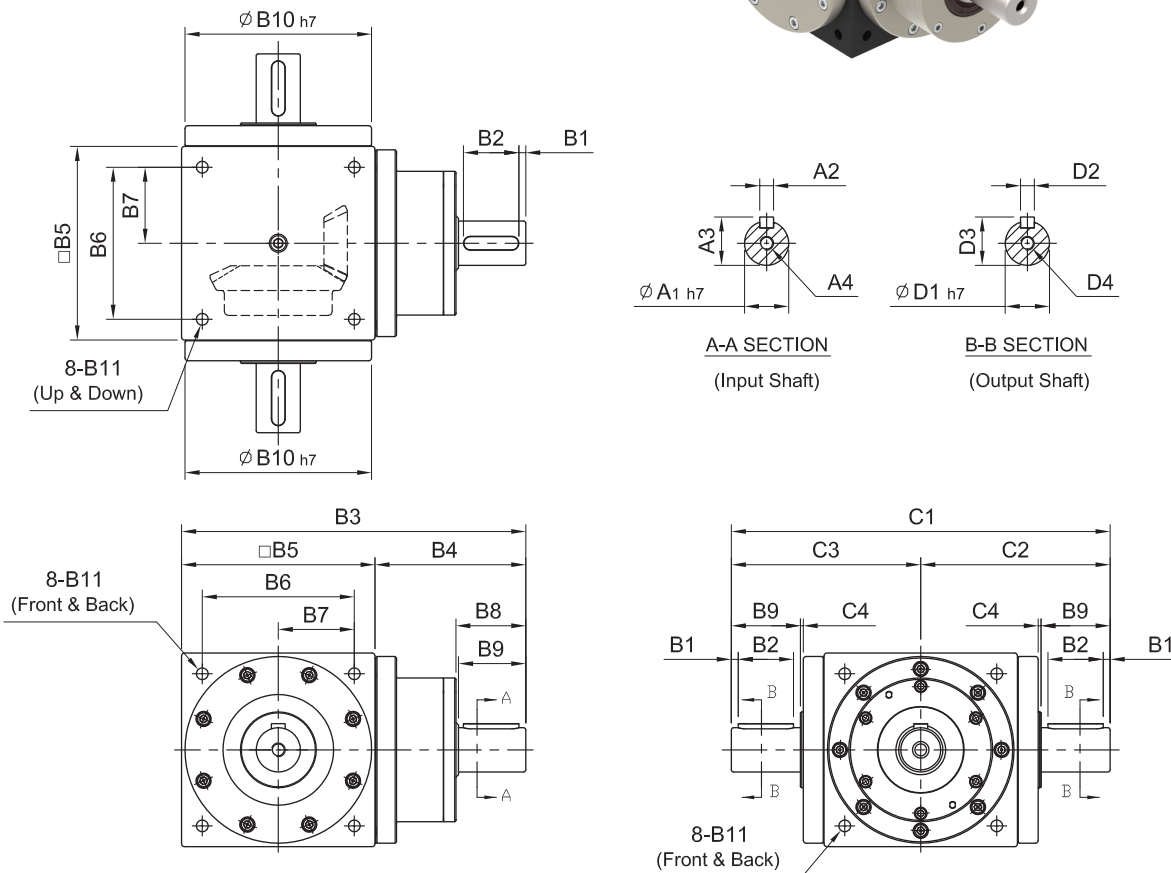

unit: mm

Model Code	65	65(1:1)	75	90	110	140	170	210	
A	A1	14	14	16	18	22	32	40	50
	A2	5	5	5	6	6	10	12	14
	A3	16	16	18	20.5	24.5	35	43	53.5
	A4	M5 x P0.8	M5 x P0.8	M5 x P0.8	M8 x P1.25	M8 x P1.25	M10 x P1.5	M12 x P1.75	M12 x P1.75
B	B1	2.5	2.5	2.5	5	5	5	5	5
	B2	15	15	25	25	30	40	50	65
	B3	127.5	127.5	143	168.5	207	250	300	375
	B4	62.5	62.5	67.5	78.5	97	110	130	165
	B5	65	65	75	90	110	140	170	210
	B6	52	52	60	72	88	110	134	170
	B7	26	26	30	36	44	55	67	85
	B8	22	22	32	38	43	53.5	64	77
	B9	20	20	30	35	40	50	60	75
	B10	62	64	73	88	106	135	164	205
	B11	M5 x P0.8	M5 x P0.8	M6 x P1.0	M6 x P1.0	M8 x P1.25	M10 x P1.5	M12 x P1.75	M16 x P2.0
C	C1	124	129	160	188	224	274	324	400
	C2	62	64.5	80	94	112	137	162	200
	C3	62	64.5	80	94	112	137	162	200
	C4	2	2	2	2	2	2	2	2
D	D1	14	14	16	18	22	32	40	50
	D2	5	5	5	6	6	10	12	14
	D3	16	16	18	20.5	24.5	35	43	53.5
	D4	M5 x P0.8	M5 x P0.8	M5 x P0.8	M5 x P0.8	M5 x P0.8	M10 x P1.5	M12 x P1.75	M12 x P1.75
Weight	重量	2.1	2.1	2.8	4.9	8.59	15.5	25	53

ST-YV series

RATIO : 1.2.3.4.5 (單段 1-Stage)

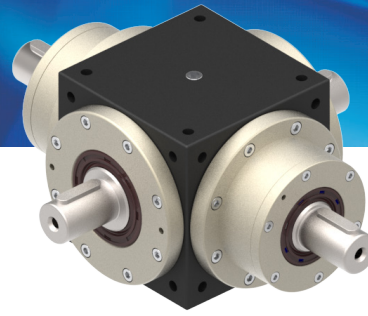

雙入力軸心 - 雙出力軸心

Double Input Shaft - Double Output Shaft

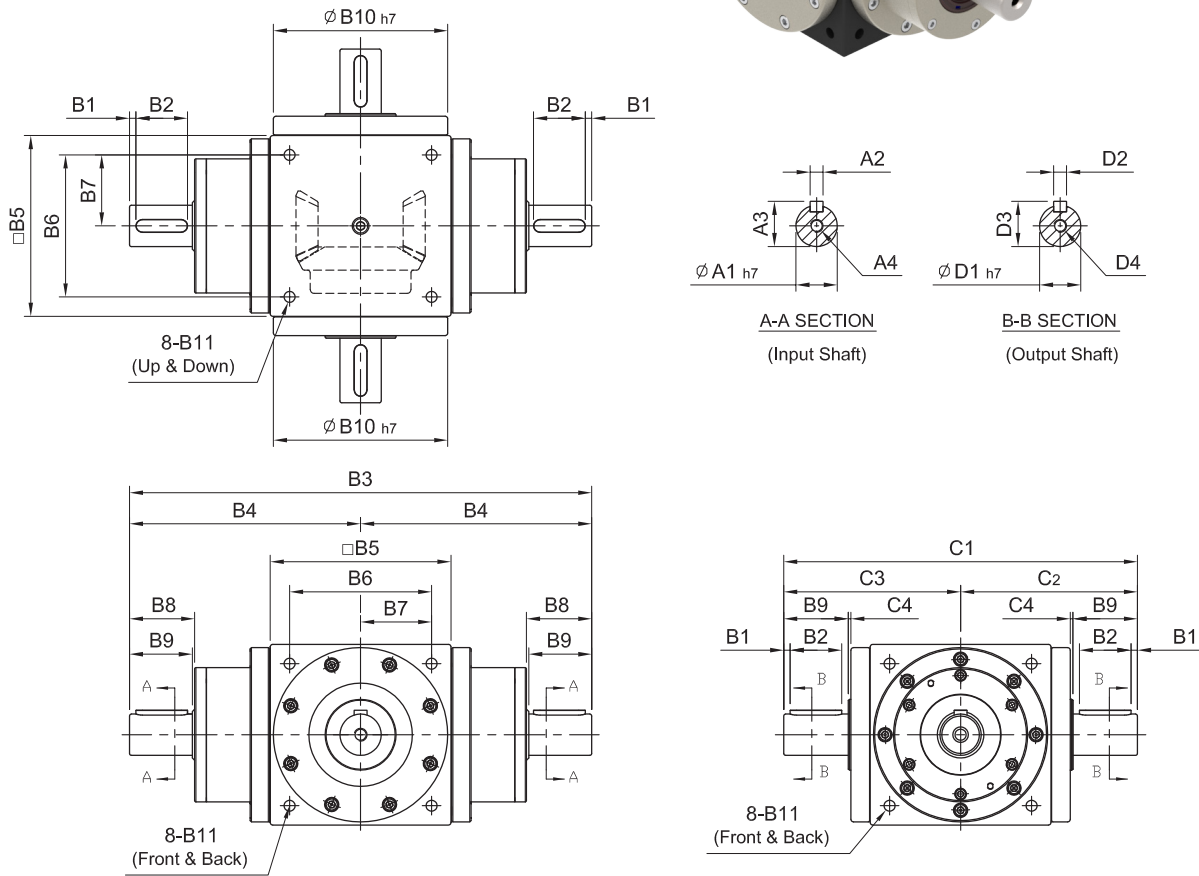

unit: mm

A	Model Code	65	65(1:1)	75	90	110	140	170	210
	A1	14	14	16	18	22	32	40	50
A2	5	5	5	6	6	10	12	14	
A3	16	16	18	20.5	24.5	35	43	53.5	
A4	M5 x P0.8	M5 x P0.8	M5 x P0.8	M8 x P1.25	M8 x P1.25	M10 x P1.5	M12 x P1.75	M12 x P1.75	
B	B1	2.5	2.5	2.5	5	5	5	5	5
	B2	15	15	25	25	30	40	50	65
	B3	190	190	210	247	304	360	430	540
	B4	95	95	105	123.5	152	180	215	270
	B5	65	65	75	90	110	140	170	210
	B6	52	52	60	72	88	110	134	170
	B7	26	26	30	36	44	55	67	85
	B8	22	22	32	38	43	53.5	64	77
	B9	20	20	30	35	40	50	60	75
	B10	62	64	73	88	106	135	164	205
C	B11	M5 x P0.8	M5 x P0.8	M6 x P1.0	M6 x P1.0	M8 x P1.25	M10 x P1.5	M12 x P1.75	M16 x P2.0
	C1	124	129	160	188	224	274	324	400
	C2	62	64.5	80	94	112	137	162	200
	C3	62	64.5	80	94	112	137	162	200
D	C4	2	2	2	2	2	2	2	2
	D1	14	14	16	18	22	32	40	50
	D2	5	5	5	6	6	10	12	14
	D3	16	16	18	20.5	24.5	35	43	53.5
Weight	D4	M5 x P0.8	M5 x P0.8	M5 x P0.8	M5 x P0.8	M5 x P0.8	M10 x P1.5	M12 x P1.75	M12 x P1.75
	重量	2.85	2.85	3.6	6.2	11.5	18	28	57

ST-FP series

RATIO : 2.3.4.5 (單段 1-Stage)

入力法蘭 - 螺桿式
Input Flange - Ball Screw

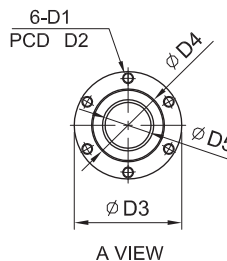
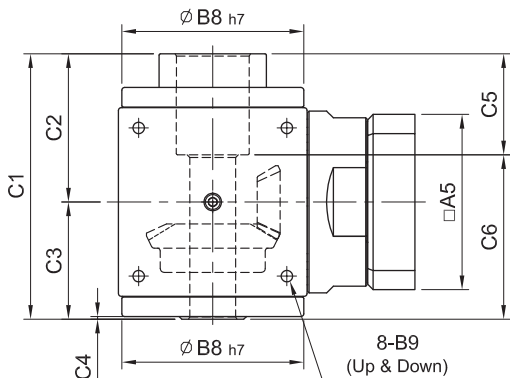
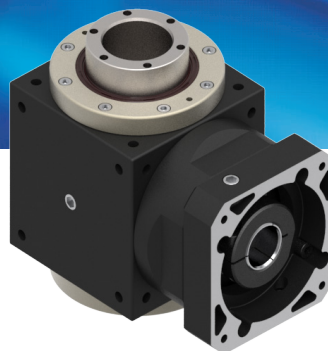

R 軸
Shaft Direction

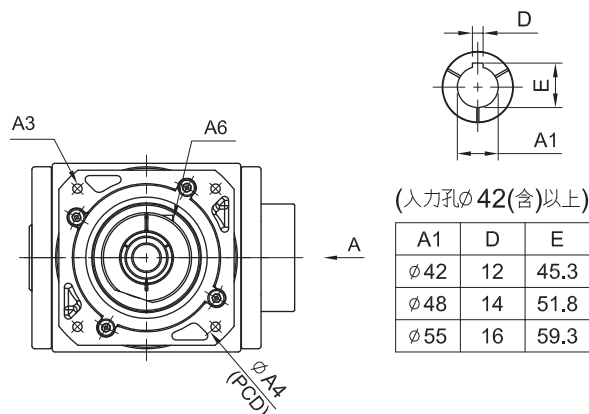
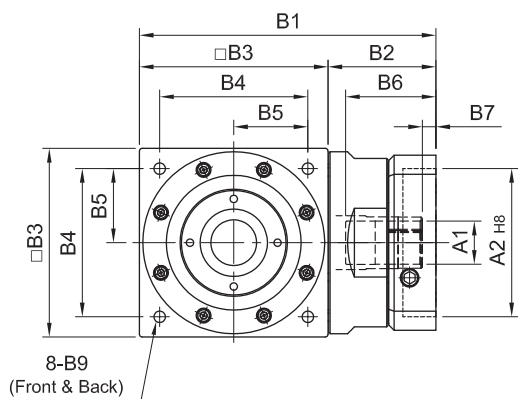

unit: mm

Model Code	75	90	110	140	170	210
	A					
A1	14	19 · 24	22 · 24	28 · 32	35	42 · 48 · 55
A2	50 · 60 · 70	70 · 80 · 95 · 110	70 · 80 · 95 · 110	95 · 110 · 130	110 · 130 · 180	114.3 · 180 · 230
A3	M4 · M5 · M6	M5 · M6 · M8	M5 · M6 · M8	M6 · M8 · M10	M8 · M10 · M120	M10 · M12 · M16
A4	70 · 75 · 90	90 · 100 · 115 · 145	90 · 100 · 115 · 145	115 · 145 · 165	145 · 165 · 200	200 · 215 · 265
A5	64 · 70 · 80	92 · 110 · 130	92 · 110 · 130	122 · 130 · 150	146 · 150 · 190	182 · 200 · 250
A6	M5 x P0.8	M6 x P1.0	M6 x P1.0	M8 x P1.25	M10 x P1.5	M10 x P1.5
B						
B1	115	148 · 162	177 · 191	224	274	357 · 359
B2	40	58 · 72	67 · 81	84	104	147
B3	75	90	110	140	170	210
B4	60	72	88	110	134	170
B5	30	36	44	55	67	85
B6	36	51 · 65.5	51 · 65.5	67	84.5	117
B7	7	9 · 23.5	9 · 23.5	10	9.5	14 · 16
B8	73	88	106	135	164	205
B9	M6 x P1.0	M6 x P1.0	M8 x P1.25	M10 x P1.5	M12 x P1.75	M16 x P2.0
C						
C1	106	127	156	197	223	267
C2	57	68	84	109	121	142
C3	49	59	72	88	102	125
C4	1.25	2	2	2	2.25	2.25
C5	33	44	55	75	72	82
C6	73	83	101	122	153	185
D						
D1	M4 x P0.7	M5 x P0.8	M5 x P0.8	M8 x P1.25	M10 x P1.5	M10 x P1.5
D2	36	40	45	70	77	84
D3	41.7	46.7	57.7	79.7	89.7	99.7
D4	26	30	36	54	58	64
D5	15	18	22	34	38	42
Weight	重量	4.3	7.1	14.9	24.5	46

ST-RP series

RATIO : 10.15.20.25.30.40.50 (雙段 2-Stage)

搭配行星減速機 - 螺桿式

Fitted with Planetary Reducer - Ball Screw

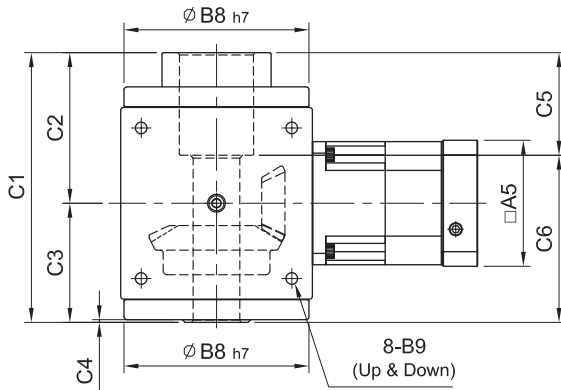
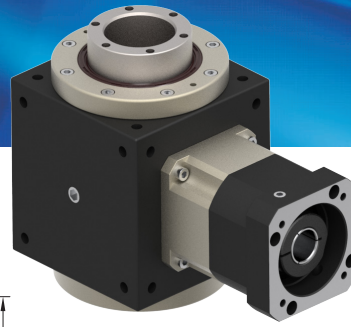

R 軸
Shaft Direction

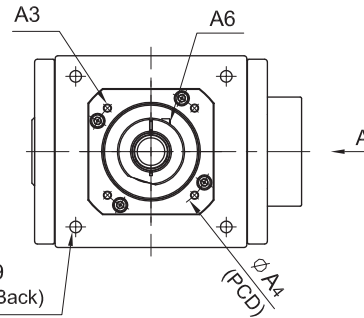
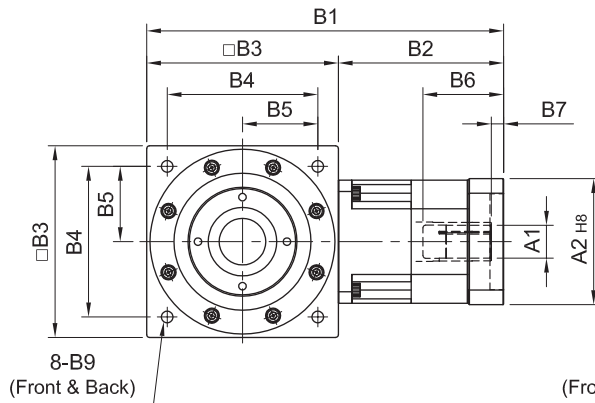
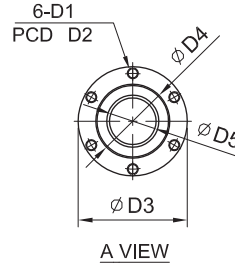

unit: mm

Model Code	75	90	110	140	170	210	
A	A1	8 · 11	14	14 · 19	19 · 24	28 · 32	35
	A2	30 · 40 · 50	50 · 60 · 70	50 · 70 · 80 · 95	70 · 80 · 95 · 110	95 · 110 · 130	110 · 130 · 180
	A3	M3 · M4 · M5	M4 · M5 · M6	M5 · M6	M5 · M6 · M8	M6 · M8 · M10	M8 · M10 · M12
	A4	46 · 60 · 63	70 · 75 · 90	70 · 90 · 100 · 115	90 · 100 · 115 · 145	115 · 145 · 165	145 · 165 · 200
	A5	46 · 55	64 · 70 · 80	80 · 92 · 110	92 · 110 · 130	122 · 130 · 150	146 · 150 · 190
	A6	M4 x P0.7	M5 x P0.8	M5 x P0.8	M6 x P1.0	M8 x P1.25	M10 x P1.5
B	B1	149	165	191	260	313	394
	B2	62	75	81	120	143	184
	B3	75	90	110	140	170	210
	B4	60	72	88	110	134	170
	B5	30	36	44	55	67	85
	B6	26	33.5	33.5	59	67	85
	B7	5	6	6	9	10	10
	B8	73	88	106	135	164	205
	B9	M6 x P1.0	M6 x P1.0	M8 x P1.25	M10 x P1.5	M12 x P1.75	M16 x P2.0
C	C1	106	127	156	197	223	267
	C2	57	68	84	109	121	142
	C3	49	59	72	88	102	125
	C4	1.25	2	2	2	2.25	2.25
	C5	33	44	55	75	72	82
	C6	73	83	101	122	153	185
D	D1	M4 x P0.7	M5 x P0.8	M5 x P0.8	M8 x P1.25	M10 x P1.5	M10 x P1.5
	D2	36	40	45	70	77	84
	D3	41.7	46.7	57.7	79.7	89.7	99.7
	D4	26	30	36	54	58	64
	D5	15	18	22	34	38	42
Weight	重量	3.6	4.8	8.5	14.2	24	52

ST-DP series

RATIO : 2.3.4.5 (單段 1-Stage)

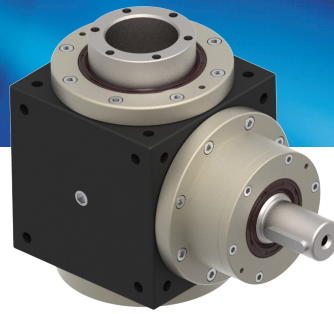

單入力軸心 - 螺桿式

Single Input Shaft - Ball Screw

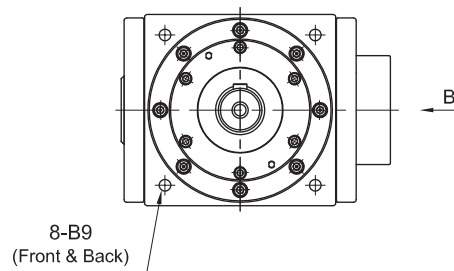
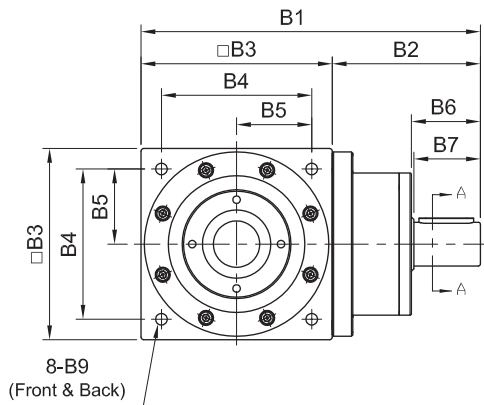
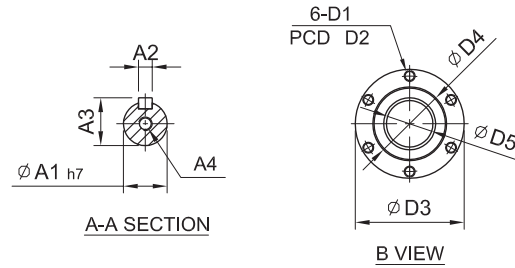
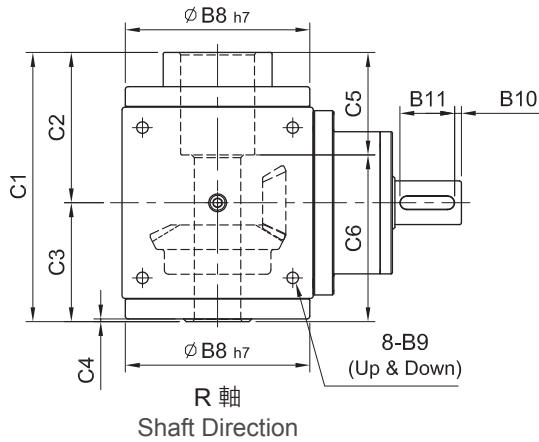

unit: mm

Model Code	75	90	110	140	170	210
A	A1	16	18	22	32	50
	A2	5	6	6	10	14
	A3	18	20.5	24.5	35	53.5
	A4	M5 x P0.8	M8 x P1.25	M8 x P1.25	M10 x P1.5	M12 x P1.75
B	B1	143	169	207	250	375
	B2	67.5	79	97	110	130
	B3	75	90	110	140	170
	B4	60	72	88	110	134
	B5	30	36	44	55	67
	B6	32	38	43	53.5	64
	B7	30	35	40	50	60
	B8	73	88	106	135	164
B9	M6 x P1.0	M6 x P1.0	M8 x P1.25	M10 x P1.5	M12 x P1.75	M16 x P2.0
B10	2.5	5	5	5	5	5
B11	25	25	30	40	50	65
C	C1	106	127	156	197	223
	C2	57	68	84	109	121
	C3	49	59	72	88	102
	C4	1.25	2	2	2	2.25
	C5	33	44	55	75	72
	C6	73	83	101	122	153
D	D1	M4 x P0.7	M5 x P0.8	M5 x P0.8	M8 x P1.25	M10 x P1.5
	D2	36	40	45	70	77
	D3	41.7	46.7	57.7	79.7	89.7
	D4	26	30	36	54	58
	D5	15	18	22	34	38
Weight	重量	2.8	4.9	8.59	15.5	25

ST-YP series

RATIO : 2.3.4.5 (單段 1-Stage)

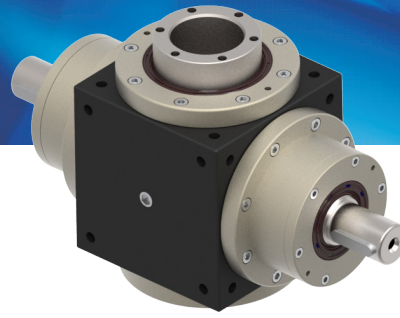

雙入力軸心 - 螺桿式

Double Input Shaft - Ball Screw

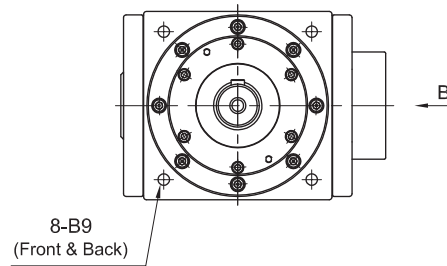
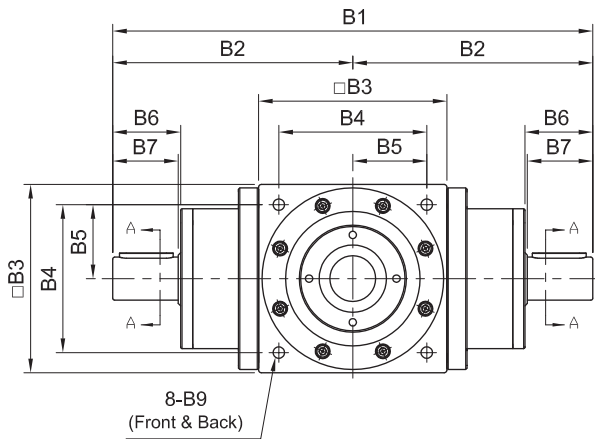
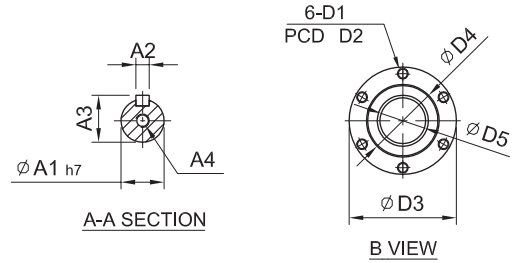
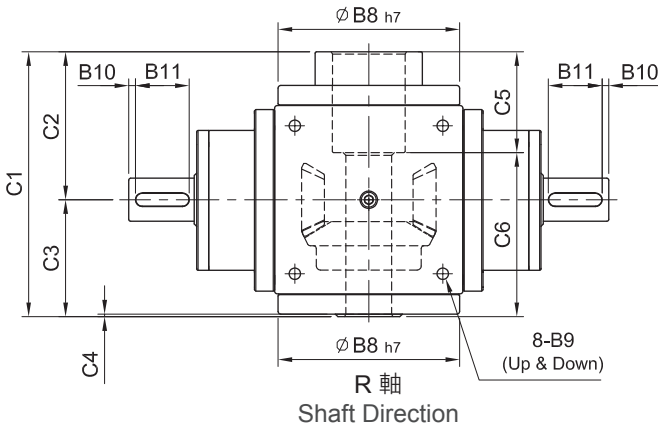

unit: mm

Model Code	75	90	110	140	170	210	
	A						
A1	16	18	22	32	40	50	
A2	5	6	6	10	12	14	
A3	18	20.5	24.5	35	43	53.5	
A4	M5 x P0.8	M8 x P1.25	M8 x P1.25	M10 x P1.5	M12 x P1.75	M12 x P1.75	
B							
B1	210	247	304	360	430	540	
B2	105	123.5	152	180	215	270	
B3	75	90	110	140	170	210	
B4	60	72	88	110	134	170	
B5	30	36	44	55	67	85	
B6	32	38	43	53.5	64	77	
B7	30	35	40	50	60	75	
B8	73	88	106	135	164	205	
B9	M6 x P1.0	M6 x P1.0	M8 x P1.25	M10 x P1.5	M12 x P1.75	M16 x P2.0	
B10	2.5	5	5	5	5	5	
B11	25	25	30	40	50	65	
C							
C1	106	127	156	197	223	267	
C2	57	68	84	109	121	142	
C3	49	59	72	88	102	125	
C4	1.25	2	2	2	2.25	2.25	
C5	33	44	55	75	72	82	
C6	73	83	101	122	153	185	
D							
D1	M4 x P0.7	M5 x P0.8	M5 x P0.8	M8 x P1.25	M10 x P1.5	M10 x P1.5	
D2	36	40	45	70	77	84	
D3	41.7	46.7	57.7	79.7	89.7	99.7	
D4	26	30	36	54	58	64	
D5	15	18	22	34	38	42	
Weight	重量	3.6	6.2	11.5	18	28	57

Reference Information of Ball Screw

滾珠螺桿參考資料

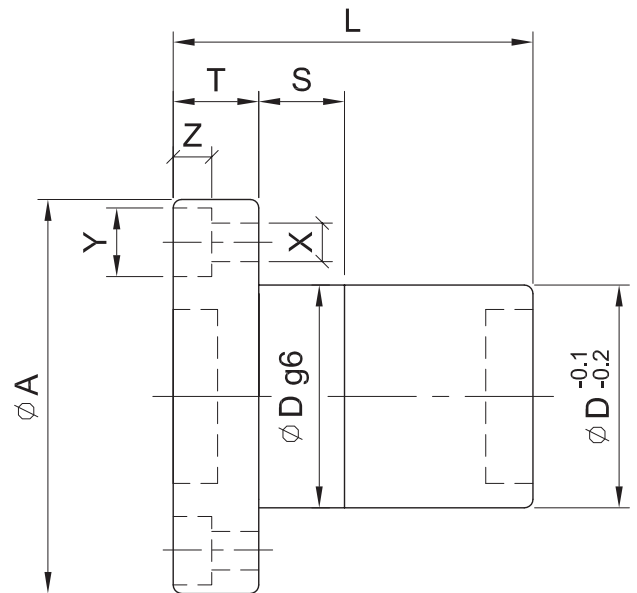
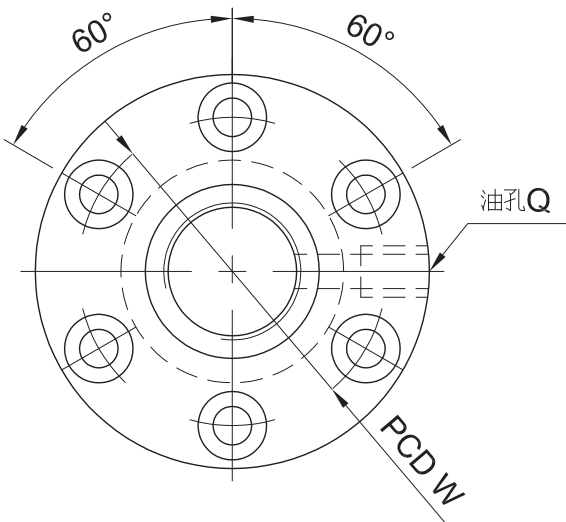
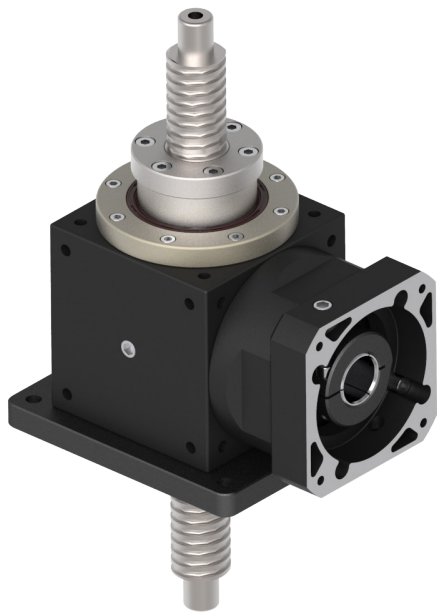

配合減速機 型號 Model of Reducer	螺桿尺寸 Screw Size		基本額定負荷 Basic Rate Load (kgf)		螺帽 Nut		法蘭 Flange			配合 FIT	螺絲孔 Screw Bolt			油孔 Oil Hole Q	螺桿 長度 Length
	外徑 O.D.	導程 Lead	動負荷 Dynamic	靜負荷 Static	Dg6	L	A	T	W		S	X	Y		
75	14	5	720	1010	26	42	46	10	36	10	4.5	8	4.5	M6 x P1.0	≤ 500
90	16	6	980	1650	30	55	54	12	40	12	5.5	9.5	5.5	M6 x P1.0	≤ 800
110	20	10	860	1710	36	66	57	12	45	12	5.5	9.5	5.5	M6 x P1.0	≤ 1000
140	32	10	3340	7080	54	90	88	16	70	15	9	14	8.5	M8 x P1	≤ 1200
170	36	10	3600	8280	58	89	98	18	77	20	11	17.5	11	M8 x P1	≤ 1500
210	40	10	4670	11830	64	99	106	18	84	20	11	17.5	11	M8 x P1	≤ 1500

FT series

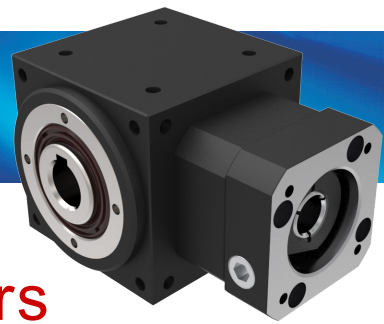

Indication of Model Numbers

機種型號表示

FT	60	F	O	B	5	MOTOR
減速機機型 Type	型號 Model	入力表示 Input	出力表示 Output	軸承形式 Bearing	速比 Ratio	馬達型號 Motor Type
FT	60 70	F: 入力法蘭 Input Flange R44: 減速機 Reducer 1-Stage: R44 · R62... 2-Stage: R44S · R62S... 2-Stage (A-Type): R62A...	O: 中空軸 Hollow Shaft P: 出力盤式 Fixing Flange C: 迫緊環 Set Collar	B: 滾珠軸承 Ball Bearing	2 3 4 5 10 15 20 25 30 40 50	

規格 Model No.	代號	單位 Unit	單段 1-Stage			雙段 2-Stage		
			速比 Ratio	60	70	速比 Ratio	60	70
額定輸出扭矩 / Rated Output Torque (Nominal output torque)	T_{2N}	Nm	2	15	22	10	15	22
			3	13	18	15	13	18
			4	13	18	20	13	18
			5	12	16	25	12	16
						30	13	18
						40	13	18
						50	12	16
最大加速扭矩 / Max. Acceleration Torque	T_{2B}	Nm	2~5 10~50	1.5 倍額定輸出扭矩		1.5 Times of Rated Output Torque		
額定輸入轉速 / Rated Input Speed	n_{1N}	rpm	2~5	3,000	3,000	10~50	3,000	3,000
最大輸入轉速 / Max. Input Speed	n_{1B}	rpm	2~5	7,000	7,000	10~50	7,000	7,000
背隙 / Backlash		arcmin	2~5	≤ 10	≤ 10	10~50	≤ 12	≤ 12
容許徑向力 / Max. Radial Force 滾珠軸承 Ball Bearing	F_{2rB}	N	2~5	600	800	10~50	600	800
容許軸向力 / Max. Axial Force 滾珠軸承 Ball Bearing	F_{2aB}	N	2~5	300	400	10~50	300	400
使用壽命 / Service Life	L_H	hr	2~5 10~50	S5 周期運轉: >20,000 (S1 連續運轉: >10,000 hrs) S5 Cycle Operation: >20,000 (S1 Continuous peration: >10,000 hrs)				
效率 / Efficiency	η	%	2~5	94% ~ 98%		10~50	90% ~ 94%	
使用溫度 / Operating Temperature		°C	2~5 10~50	-10°C ~ +90°C				
潤滑 / Lubrication			2~5 10~50	全合成潤滑油脂 Synthetic Grease				
噪音值 / Noise Level		dB	2~5	68	70	10~50	70	72

轉動慣量 Mass Moments of Inertia (kgcm²)

規格 Model No.	代號	單位 Unit	單段 1-Stage			雙段 2-Stage		
			速比 Ratio	60	70	速比 Ratio	60	70
轉動慣量 / Mass Moments of Inertia	kgcm ²	Nm	2	0.32	0.80	10	0.04	0.10
			3	0.30	0.75	15	0.04	0.10
			4	0.30	0.70	20	0.04	0.10
			5	0.29	0.68	25	0.04	0.10
						30	0.04	0.10
						40	0.04	0.10
						50	0.04	0.10

MODEL : FT-60

RATIO : 2.3.4.5 (單段 1-Stage)

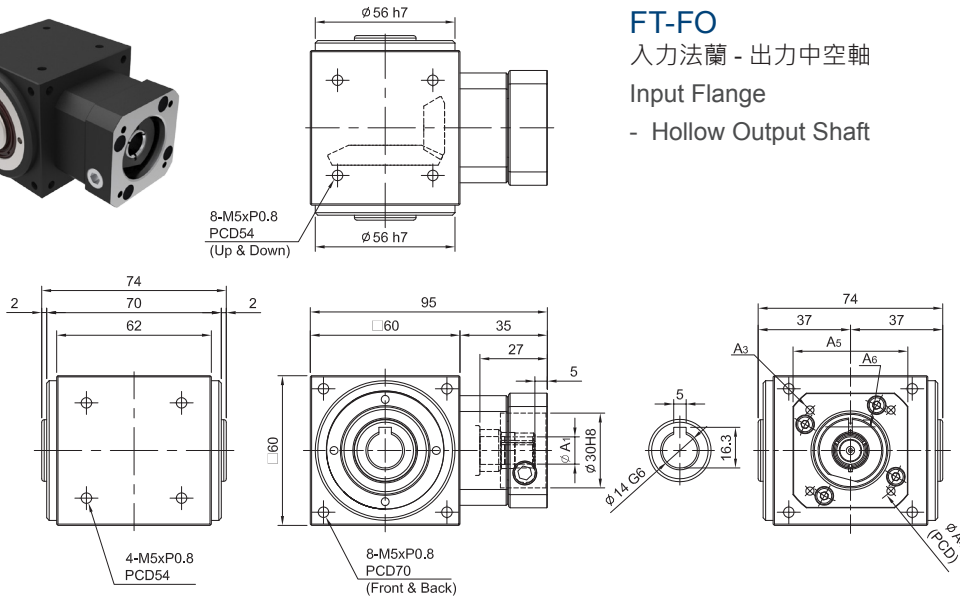
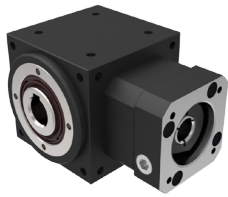

FT-FO

入力法蘭 - 出力中空軸
Input Flange
- Hollow Output Shaft

單位 unit:mm

Model Code	60
A1	11
A2	30、40、50
A3	M3、M4、M5
A4	46、60、63
A5	46、55
A6	M4 x P0.7

MODEL : FT-60

RATIO : 10.15.20.25.30.40.50 (雙段 2-Stage)

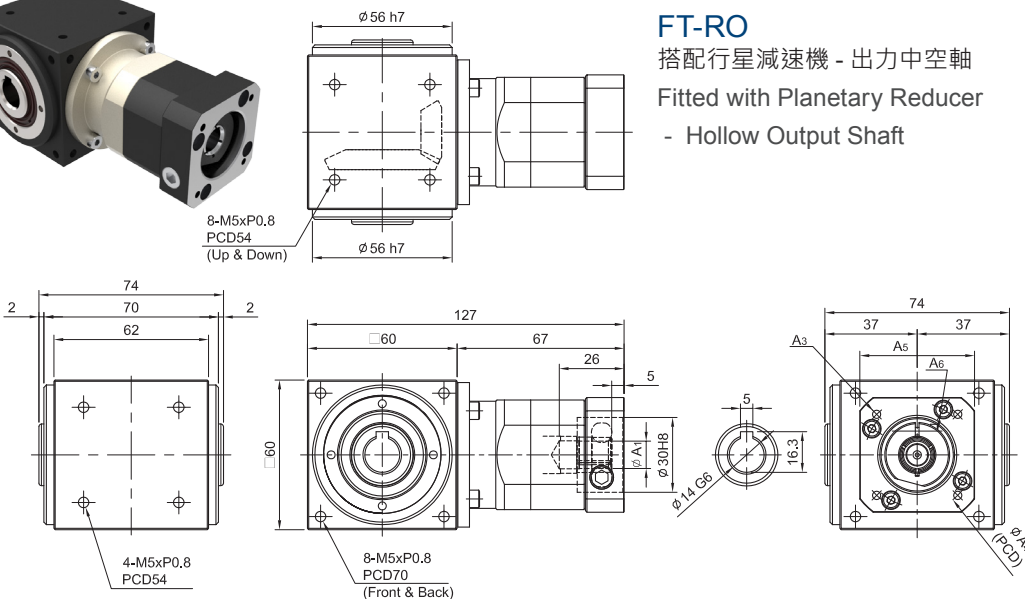
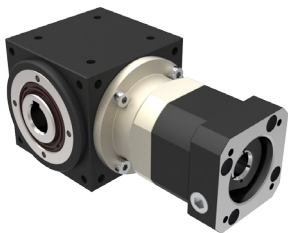

FT-RO

搭配行星減速機 - 出力中空軸
Fitted with Planetary Reducer
- Hollow Output Shaft

單位 unit:mm

Model Code	60
A1	8、11
A2	30、40、50
A3	M3、M4、M5
A4	46、60、63
A5	46、55
A6	M4 x P0.7

MODEL : FT-70

RATIO : 2.3.4.5 (單段 1-Stage)

FT

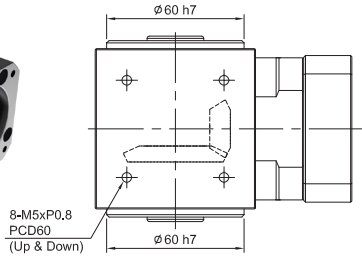
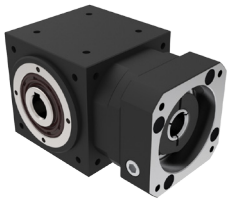

FT-FO

入力法蘭 - 出力中空軸
Input Flange
- Hollow Output Shaft

單位 unit:mm

Model Code	70
A1	14
A2	50 · 60 · 70
A3	M4 · M5 · M6
A4	70 · 75 · 90
A5	64 · 70 · 80
A6	M5 x P0.8

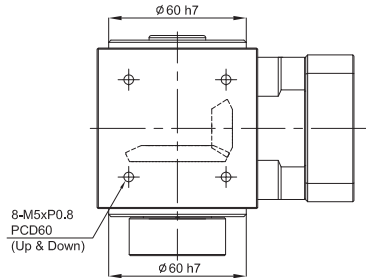
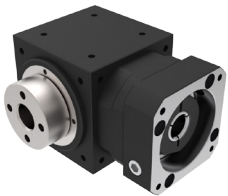
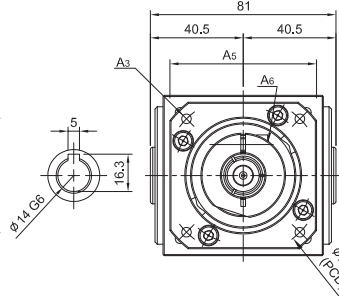
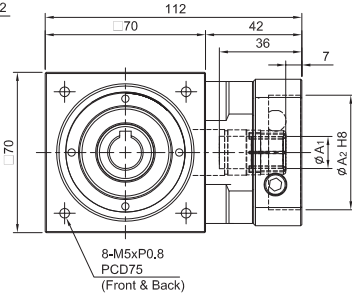
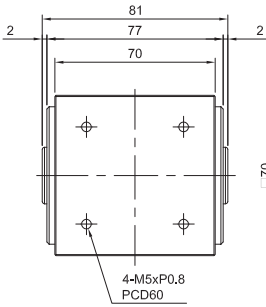

FT-FP

入力法蘭 - 出力盤式
Input Flange - Fixing Flange

單位 unit:mm

Model Code	70
A1	14
A2	50 · 60 · 70
A3	M4 · M5 · M6
A4	70 · 75 · 90
A5	64 · 70 · 80
A6	M5 x P0.8

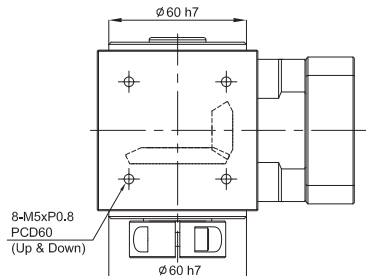
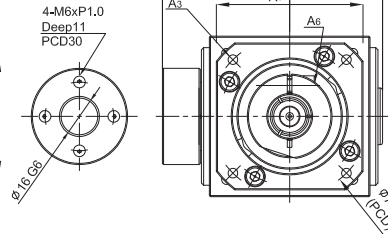
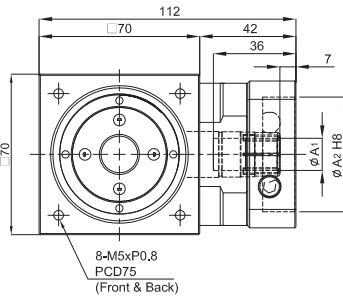
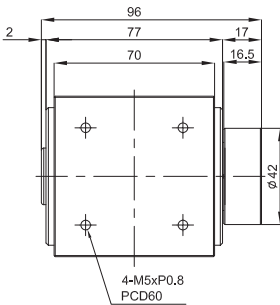

FT-FC

入力法蘭 - 出力迫緊環
Input Flange - Set Collar

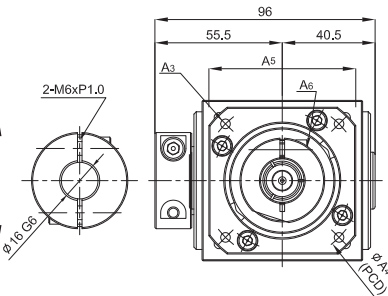
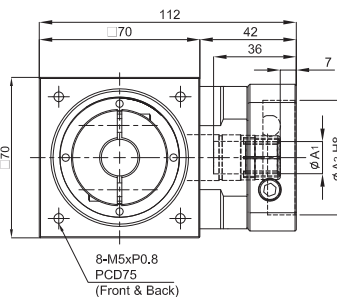
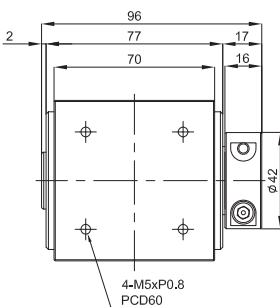

MODEL : FT-70

RATIO : 10.15.20.25.30.40.50 (雙段 2-Stage)

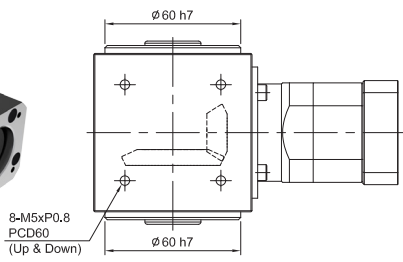
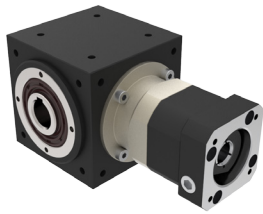

FT-RO

搭配行星減速機 - 出力中空軸
Fitted with Planetary Reducer
- Hollow Output Shaft

單位 unit:mm

Model Code	70	
A1	8 · 11	14
A2	30 · 40 · 50	50 · 60 · 70
A3	M3 · M4 · M5	M4 · M5 · M6
A4	46 · 60 · 63	70 · 75 · 90
A5	46 · 55	64 · 70 · 80
A6	M3 x P0.5	M5 x P0.8
B1	135	146
B2	65	76
B3	26	33.5
B4	5	6

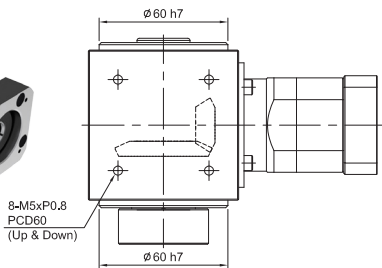
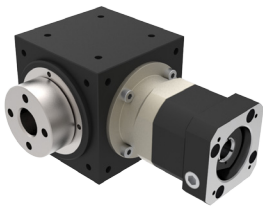
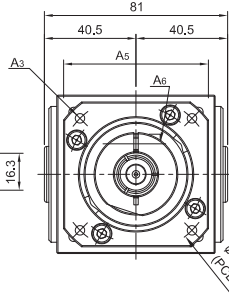
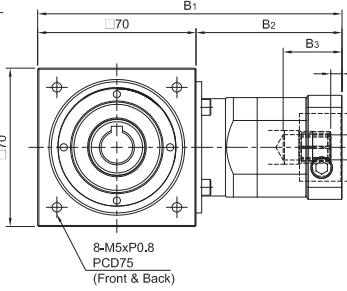
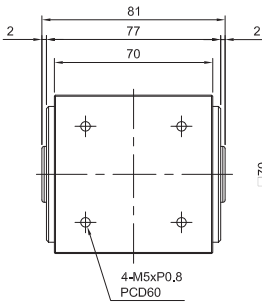

FT-RP

搭配行星減速機 - 出力盤式
Fitted with Planetary Reducer
- Fixing Flange

單位 unit:mm

Model Code	70	
A1	8 · 11	14
A2	30 · 40 · 50	50 · 60 · 70
A3	M3 · M4 · M5	M4 · M5 · M6
A4	46 · 60 · 63	70 · 75 · 90
A5	46 · 55	64 · 70 · 80
A6	M3 x P0.5	M5 x P0.8
B1	135	146
B2	65	76
B3	26	33.5
B4	5	6

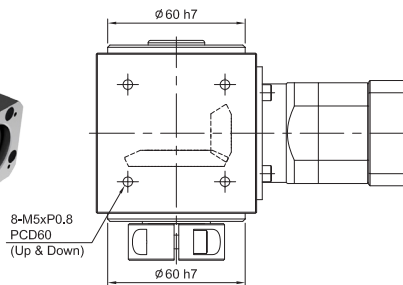
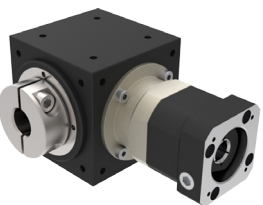
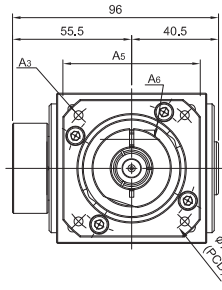
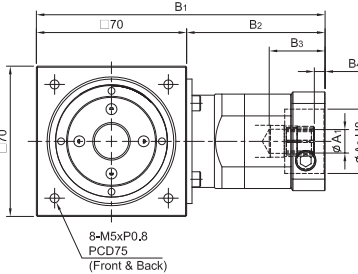
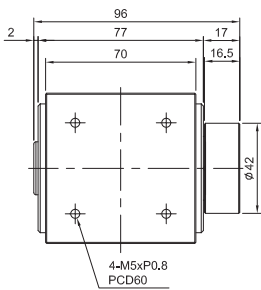

FT-RC

搭配行星減速機 - 出力迫緊環
Fitted with Planetary Reducer
- Set Collar

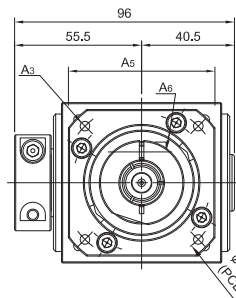
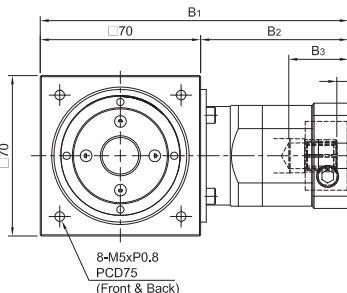
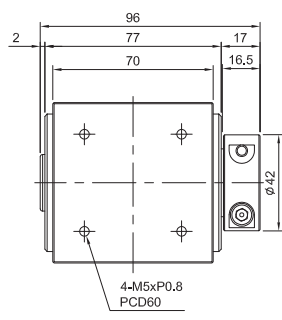

Fixing Plate

固定座

ST/FT

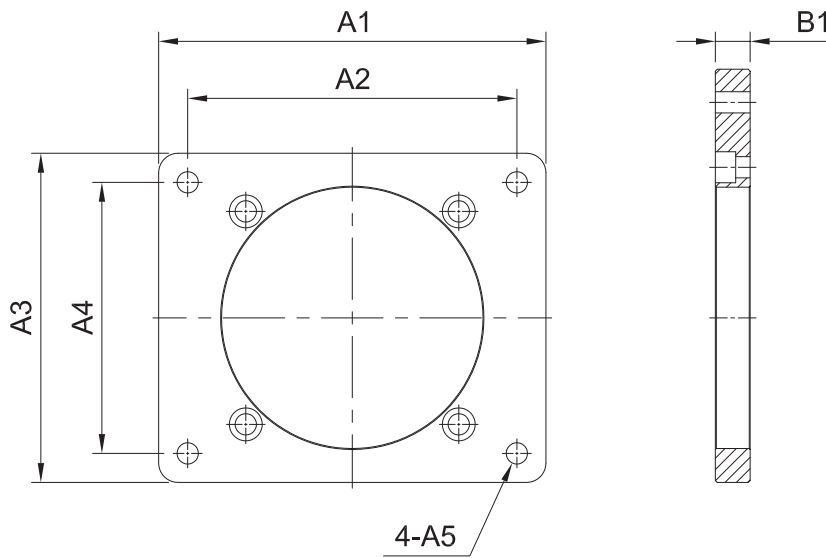

Indication of Fixing Plate

固定座料號表示

FP	75	A
型號 Model		安裝方式 Direction
65 · 75 · 90 · 110 · 140 · 170 · 210		A · B · C · D · E · F

unit:mm

Model Code	65	75	90	110	140	170	210
	A						
A1	100	110	130	160	200	230	280
A2	85	95	110	135	170	200	240
A3	85	90	110	135	170	200	250
A4	70	75	90	110	140	170	210
A5	7	7	7	9	11	13	17
B							
B1	10	12	13	16	18	18	25

Selection Direction of Fixing Plate

固定座安裝方式選擇

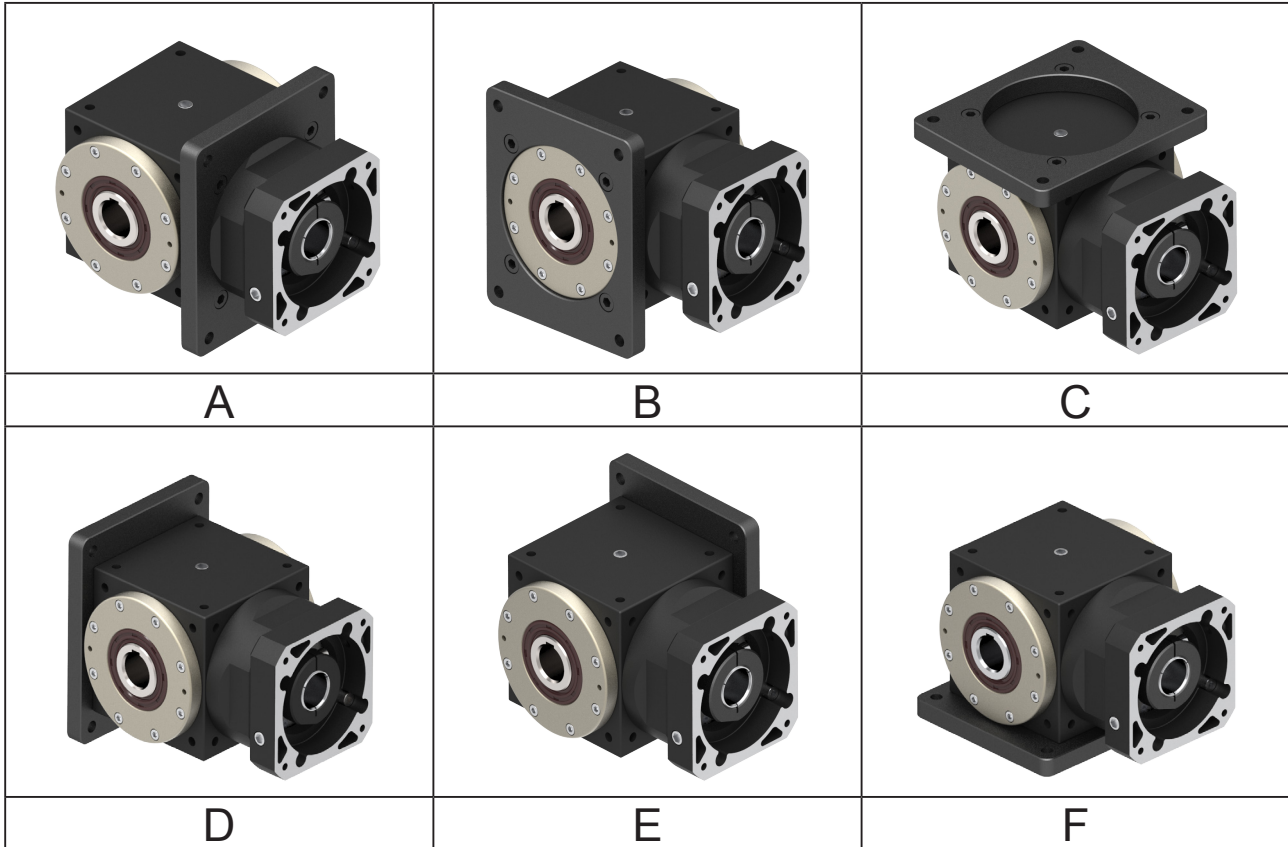

Installation Example of Fixing Plate

固定座安裝方式範例

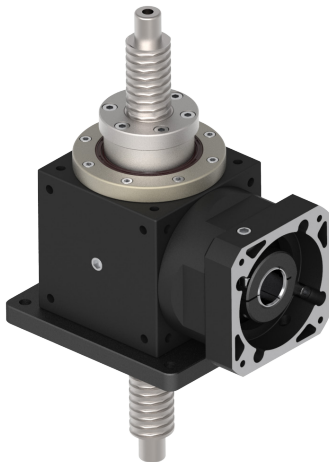

ST140-FPT-5 +
FP140-F

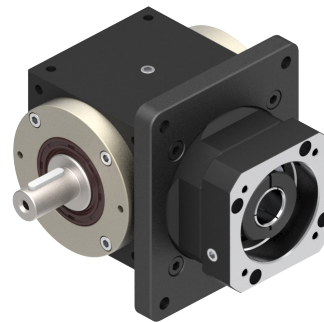

ST110-FSB-5 +
FP110-A

HY series

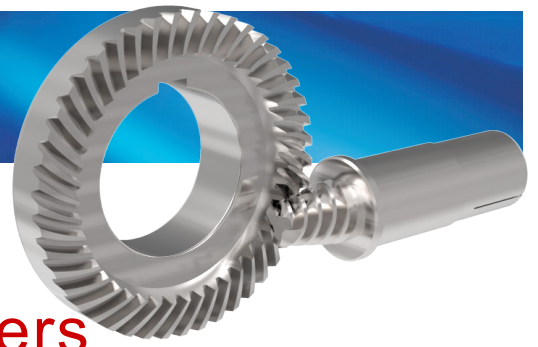

Indication of Model Numbers

機種型號表示

HY	55	F	O	B	5	L	P0
減速機機型 Type	型號 Model	入力表示 Input	出力表示 Output	軸承形式 Bearing	速比 Ratio	軸向 Shaft Direction	背隙等級 Backlash Class
HY	55 75 90 115 130 140 160 190	F: 入力法蘭 Input Flange R44: 減速機 Reducer 1-Stage: R44、R62... 2-Stage: R62S... 2-Stage (A-Type): R44A、R62A... D: 單入力軸心 (有鍵槽) Single Input Shaft (Keyway) D1: 單入力軸心 (無鍵槽) Single Input Shaft (No Keyway)	O: 出力中空軸 Hollow Output Shaft N: 單邊免鍵軸套 Single Clamping M: 雙邊免鍵軸套 Double Clamping S: 單出力軸心 (有鍵槽) Single Output Shaft (Keyway) S1: 單出力軸心 (無鍵槽) Single Output Shaft (No Keyway) V: 雙出力軸心 (有鍵槽) Double Output Shaft (Keyway) V1: 雙出力軸心 (無鍵槽) Double Output Shaft (No Keyway) P: 螺桿式 (75#~190#) Ball Screw 限用滾錐軸承 Taper Bearing Only	B: 滾珠軸承 Ball Bearing (55#~190#) T: 滾錐軸承 Taper Bearing (90#~190#)	單段 1-Stage 5, 10, 15 ----- 搭配單段 行星減速機 With 1-Stage Planetary Reducer 25 ~ 150 ----- 搭配雙段 行星減速機 With 2-Stage Planetary Reducer 250 ~ 1500	L: 左軸 Left Shaft R: 右軸 Right Shaft ----- 1. 出力形式 N、 S 可以選擇軸向 Shaft direction is optional for output type N, S. ----- 2. 出力形式 P 為 R 軸向 Output type P only for R shaft.	P0 P1 P2

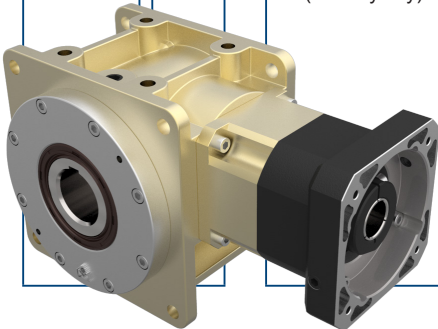

The Model & Ratio Table of Hypoid Gear Reducer Assembly Planetary Reducer 戟齒輪減速機搭配行星減速機型號及速比一覽表

型號 Model	減速比 Ratio	法蘭盤框號 Flange Model	減速機框號 Planetary Reducer Model	單段行星減速機減速比 Ratio of 1-Stage Planetary Reducer 5、10	雙段行星減速機減速比 Ratio of 2-Stage Planetary Reducer 25、50、100
55	5 10 15	44	44	搭配單段行星減速機減速比 Ratio of Bevel Gear Reducer with 1-Stage Planetary Reducer 25、50、75、100、150	搭配雙段行星減速機減速比 Ratio of Bevel Gear Reducer with 2-Stage Planetary Reducer 250、500、750、1000、1500
75		62	62		
90		90	80		
115		90	90		
130		120	120		
140		142	142		
160		142	142		
190		180	180		

Selection of Type

產品樣式選擇

入力形式 Input Type

F 入力法蘭
Input Flange

R 減速機
Reducer

D 單入力軸心
Single Input Shaft

O
出力中空軸
Hollow
Output
Shaft

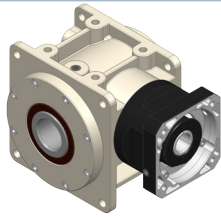

FO

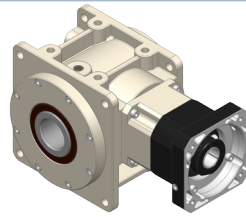

RO

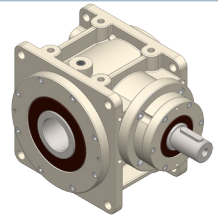

DO

N
單邊
免鍵軸套
Single
Clamping

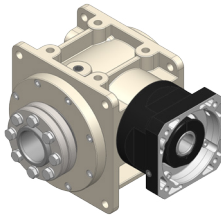

FN

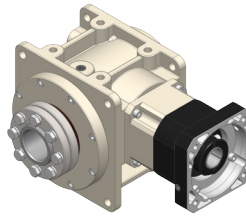

RN

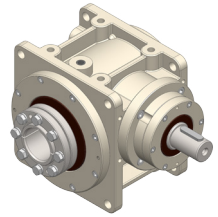

DN

M
雙邊
免鍵軸套
Double
Clamping

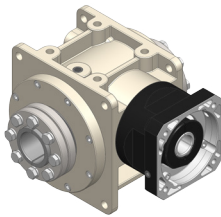

FM

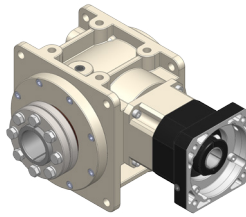

RM

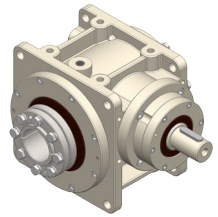

DM

S
單出力軸心
Single
Output Shaft

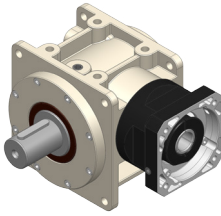

FS

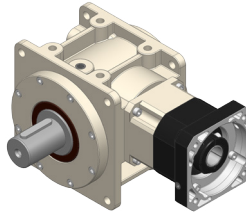

RS

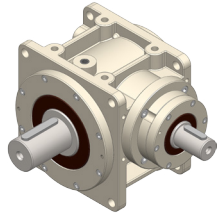

DS

V
雙出力軸心
Double
Output Shaft

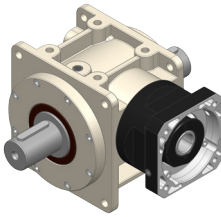

FV

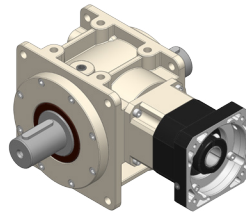

RV

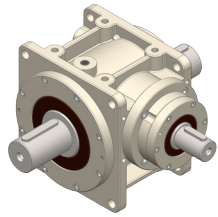

DV

P
螺桿式
Ball Screw

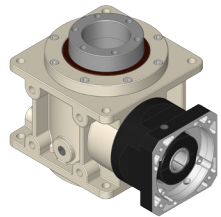

FP

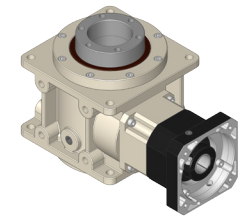

RP

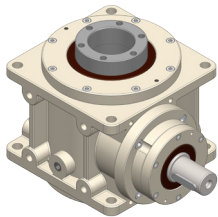

DP

出力形式
Output Type

- 出力形式 N、S 可以選擇軸向。Shaft direction is optional for output type N, S.
- 出力形式 P 為 R 軸向。Output type P only for R shaft.

Rotating Direction

旋轉方向說明

HY

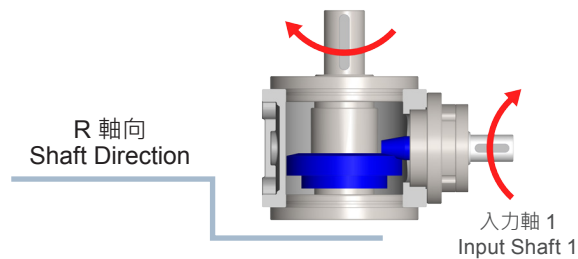
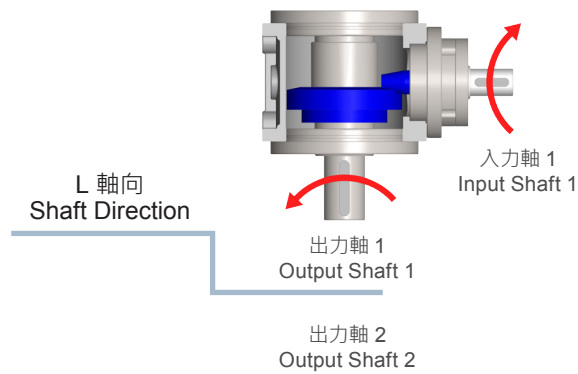
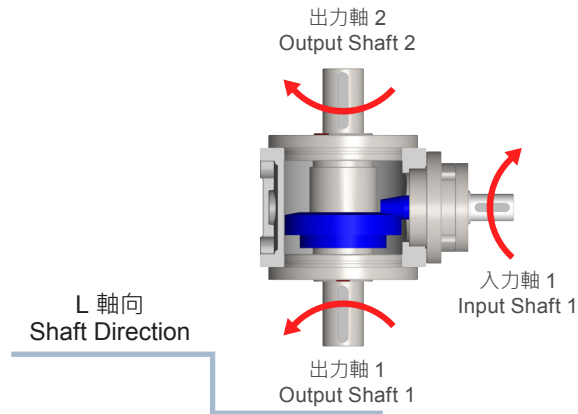
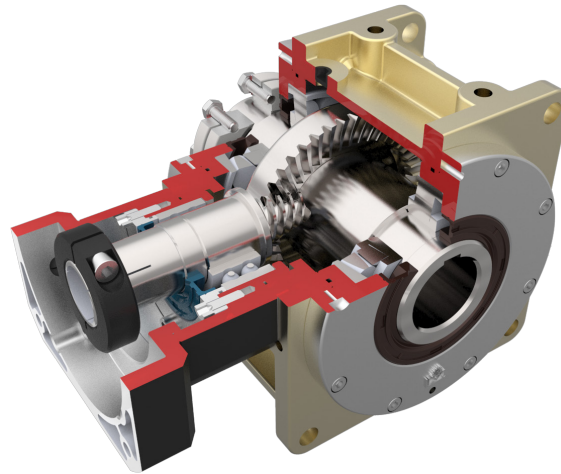

本公司出廠標準品使用「標準軸向」，R 軸向請於訂單上註明。
Standard product is L shaft direction, R shaft direction is optional.

Selection Direction of Installation

安裝方向選擇

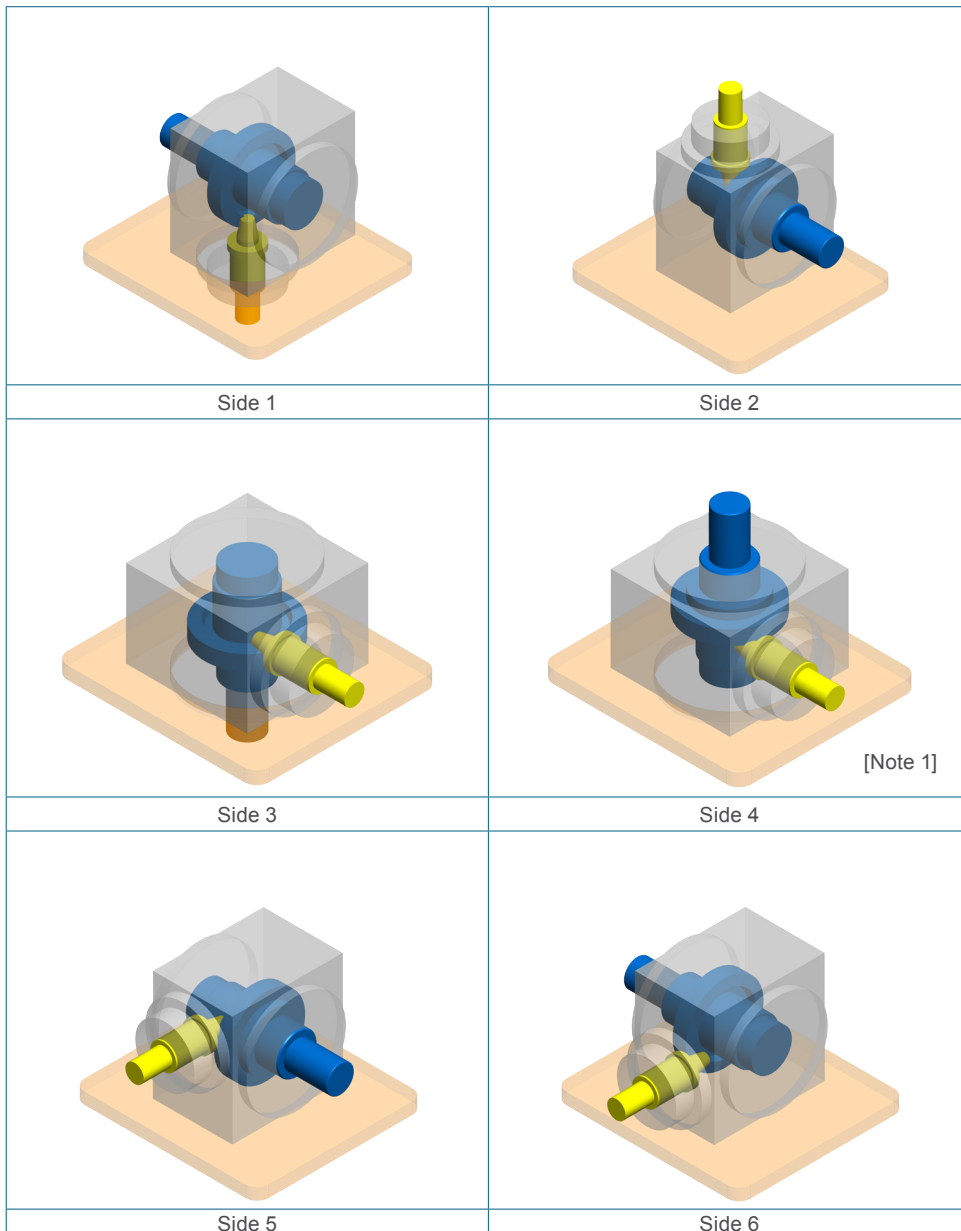
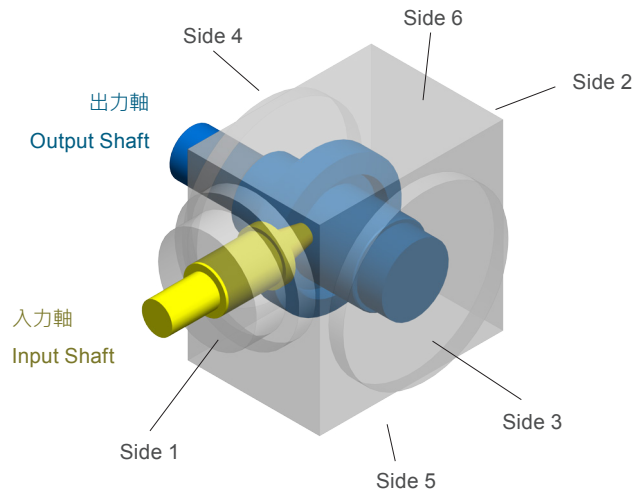

[Note 1] 出力軸端面基準線朝上時，需特別告知其使用方式。
Side 4 operation shall be avoided.

Features of HY Series

HY 系列產品特點

HY

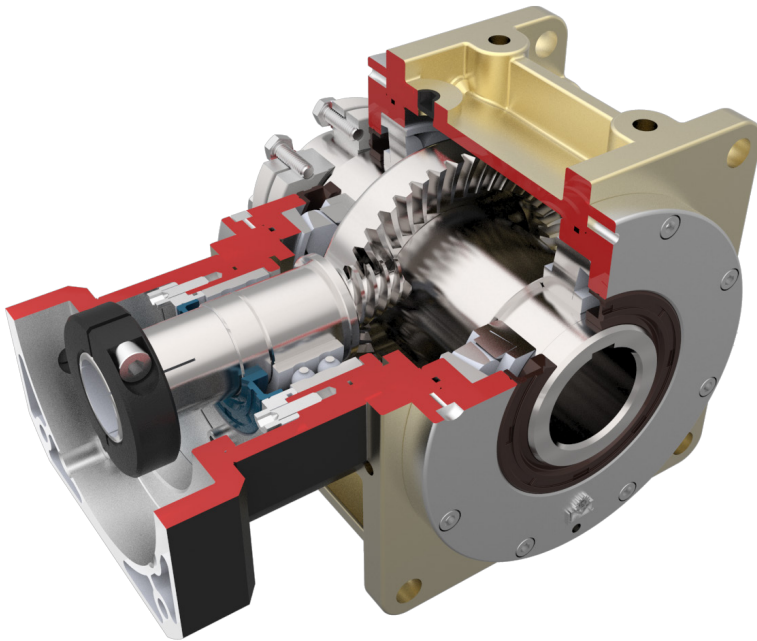

在設計 HYGear 時，已充分考慮到它將運用在及其廣泛的領域中。特別是在高動力伺服驅動應用中，將帶給用戶獨一無二的優勢。

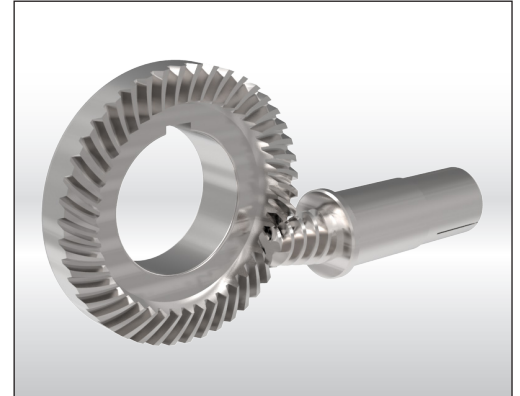

低背隙

- 格里森高減速比戟齒輪，標準品單級可達 1/15。
- 可訂製減速比單級 1/20~1/60。

Super-Reduction-Hypoid Gear

- Gleason super-reduction-hypoid gear tooth system, the max. single stage ratio is 1/15.
- Single stage ratio 1/20~1/60 is optional.

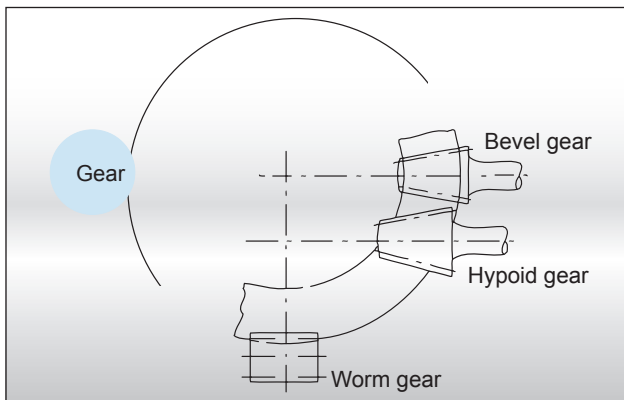

高扭矩密度

- 一體式齒箱本體確保最大剛性與耐蝕性。
- 結構緊湊，富有剛性的設計保證了在小體積，重量輕的情況下能夠達到最高扭矩及較大的減速比。

High Output Torque

- The gear box is one-piece constructed to ensure the high rigidity and corrosion-resistant capability.

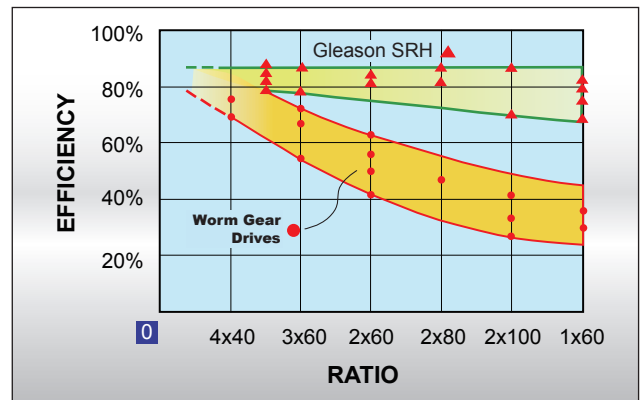

高扭矩密度

- 減速機的效率高達 90% 大大節省能源成本。

High Output Torque

- High running efficiency, the efficiency more than 90%.

Features of HY Series

HY 系列產品特點



低背隙

- 使用 Gleason 參數齒輪加工設備，加工研磨等級的螺旋傘齒輪，確保低背隙、低噪音。
- 背隙最小可達 2 弧分以內。

Low Backlash

- Using Gleason high precision CNC grinding machine to grinding the spiral bevel gears.
- Torsional backlash depending on design up to <2 arcmin

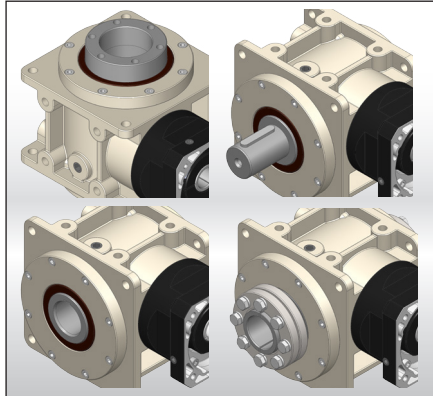

安裝位置

- 多重精密加工表面易於組裝，適用於任意安裝方向。
- 入出力軸的設計可以適用於各種工業上應用的需求。

Mounting Position

- Multiple precision machined surface is easy for assembly, suitable for any optional mounting orientation.
- Output shaft and input shaft are designed to suit for various industries applications.

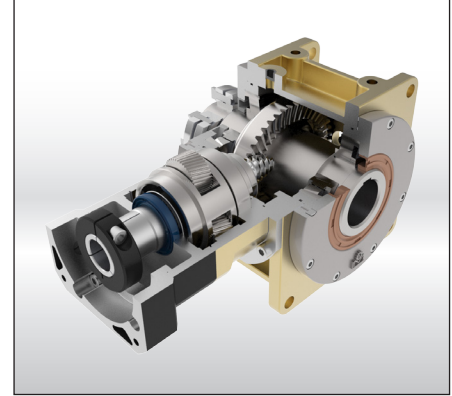

更高的減速比

- 高精密研磨的蝸線傘齒輪組結合最佳化設計的行星式齒輪組可以達到 1500:1 的減速比。

More High Gear Ratio

- High precision grinded and carburized spiral bevel gears with optimal designed planetary gear can do ratio 1500: 1.

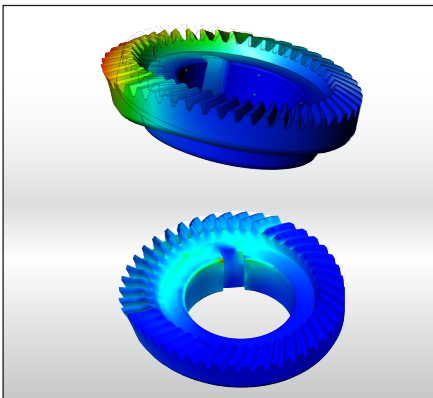

CAE 設計分析技術

- 利用 3D-CAE 軟體的設計分析技術，對減速機整體強度及螺旋傘齒輪進行分析，增加齒輪系及減速機的使用壽命。

CAE Design and Analysis

- Employs 3D-CAE software for analysis and design, the software allows for analyzing the strength of the entire gear reducer and helical teeth. Increasing the service life of gears and the gear reducer.

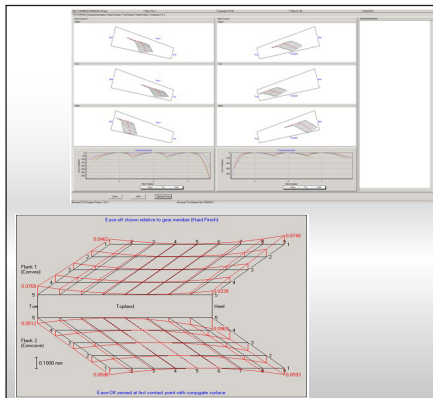

最優化的設計

- 採用 Gleason 參數齒輪設計軟件，得到最佳化接觸面積的齒印參數，保證了最高扭矩以及最小噪音。

Optimized Design

- Use Gleason's design software to design new spiral bevel gears. Through the ideal gear contact pattern for application, achieve high permissible output torque.

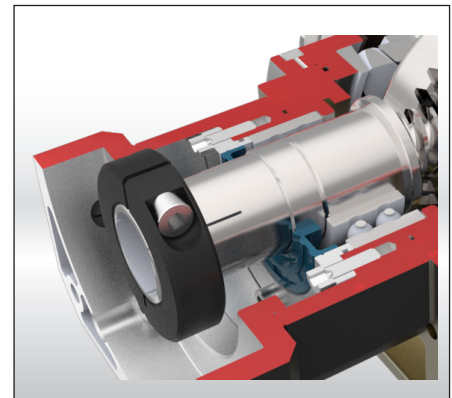

筒夾式連結機構

- 輸入端與馬達的連結採用筒夾式的鎖緊機構，並經動平衡分析，以確保在高輸入轉速下結合介面的同心度和平衡度，及零背隙的動力傳遞。

Collet Locking Mechanism

- The input-end and the motor are coupled through a collet locking mechanism. It has passed dynamical balance analysis to assure concentricity and balance on the connection and no backlash for power transmission while running at high speed.

Characteristic of HY Series

HY 系列產品特性

HY

單段減速機 1-Stage

規格 Model No.	代號	單位 Unit	速比 Ratio	55	75	90	115	130	140	160	190
額定輸出扭矩 / Rated Output Torque (Nominal output torque)	T_{2N}	Nm	5	35	70	140	260	430	720	1,100	1,440
			10	30	60	117	220	365	615	957	1,230
			15	25	50	95	180	300	510	815	1,020
最大加速扭矩 / Max. Acceleration Torque	T_{2B}	Nm	5~15	1.5 倍額定輸出扭矩 1.5 Times of Rated Output Torque							
最大輸出扭矩 / Max. Output Torque 急停扭矩 / Emergency Stop Torque	T_{2NOT}	Nm	5~15	3 倍額定輸出扭矩 3 Times of Rated Output Torque							
額定輸入轉速 / Rated Input Speed	n_{1N}	rpm	5~15	3,000	3,000	3,000	3,000	2,500	2,500	2,000	2,000
最大輸入轉速 / Max. Input Speed	n_{1B}	rpm	5~15	6,000	6,000	6,000	6,000	5,000	5,000	4,000	4,000
背隙 / Backlash	J_t	arcmin	P0	-	-	≤ 3	≤ 3	≤ 3	≤ 3	≤ 3	≤ 3
			P1	≤ 6	≤ 6	≤ 6	≤ 6	≤ 6	≤ 6	≤ 6	≤ 6
			P2	≤ 9	≤ 9	≤ 9	≤ 9	≤ 9	≤ 9	≤ 9	≤ 9
容許徑向力 / Max. Radial Force 滾珠軸承 Ball Bearing	F_{2rB}	N	5~15	1,495	2,366	2,691	4,797	5,837	7,020	9,490	12,337
容許軸向力 / Max. Axial Force 滾珠軸承 Ball Bearing	F_{2aB}	N	5~15	748	1,183	1,346	2,399	2,919	3,510	4,745	6,169
容許徑向力 / Max. Radial Force 滾錐軸承 Taper Bearing	F_{2rB}	N	5~15	-	-	5,523 6,545(P)	9,100	12,320	14,420	18,620	24,080
容許軸向力 / Max. Axial Force 滾錐軸承 Taper Bearing	F_{2aB}	N	5~15	-	-	2,762 3,273(P)	4,550	6,160	7,210	9,310	12,040
使用壽命 / Service Life	L_{H1}	hr	5~15	S5 周期運轉 : >30,000 (S1 連續運轉 : >15,000 hrs) S5 Cycle Operation: >30,000 (S1 Continuous Operation: >15,000 hrs)							
效 率 / Efficiency	η	%	5	≥ 96%							
			10~15	≥ 93%							
使用溫度 / Operating Temperature		°C	5~15	-10°C ~ +90°C							
潤 滑 / Lubrication			5~15	全合成潤滑油 Synthetic Oil							
噪 音 值 / Noise Level		dB	5~15	≤ 67	≤ 67	≤ 69	≤ 69	≤ 71	≤ 71	≤ 72	≤ 72

註 : (P) 螺桿式 NOTE: (P) Ball Screw

轉動慣量 Mass Moments of Inertia (kgcm²)

速比 Ratio	55	75	90	115	130	140	160	190
5	0.23	0.58	1.41	4.00	7.12	13.53	24.76	44.29
10	0.15	0.38	1.00	2.46	4.27	7.38	12.47	21.43
15	0.13	0.34	0.81	2.07	3.45	5.76	9.23	15.53

Characteristic of HY Series

HY 系列產品特性

雙段減速機 2-Stage

規格 Model No.	代號	單位 Unit	速比 Ratio	55	75	90	115	130	140	160	190
額定輸出扭矩 / Rated Output Torque (Nominal output torque)	T_{2N}	Nm	25, 50	35	70	140	260	430	720	1,100	1,440
			100	30	60	117	220	365	615	957	1,230
			75, 150	25	50	95	180	300	510	815	1,020
最大加速扭矩 / Max. Acceleration Torque	T_{2B}	Nm	25~150	1.5 倍額定輸出扭矩 1.5 Times of Rated Output Torque							
最大輸出扭矩 / Max. Output Torque 急停扭矩 / Emergency Stop Torque	T_{2NOT}	Nm	25~150	3 倍額定輸出扭矩 3 Times of Rated Output Torque							
額定輸入轉速 / Rated Input Speed	n_{1N}	rpm	25~150	3,000	3,000	3,000	3,000	3,000	3,000	2,000	3,000
最大輸入轉速 / Max. Input Speed	n_{1B}	rpm	25~150	6,000	6,000	6,000	6,000	5,000	5,000	4,000	4,000
背隙 / Backlash	J_t	arcmin	P0	-	-	≤ 4	≤ 4	≤ 4	≤ 4	≤ 4	≤ 4
			P1	≤ 7	≤ 7	≤ 7	≤ 7	≤ 7	≤ 7	≤ 7	≤ 7
			P2	≤ 10	≤ 10	≤ 10	≤ 10	≤ 10	≤ 10	≤ 10	≤ 10
容許徑向力 / Max. Radial Force 滾珠軸承 Ball Bearing	F_{2rB}	N	25~150	1,495	2,366	2,691	4,797	5,837	7,020	9,490	12,337
容許軸向力 / Max. Axial Force 滾珠軸承 Ball Bearing	F_{2aB}	N	25~150	748	1,183	1,346	2,399	2,919	3,510	4,745	61,69
容許徑向力 / Max. Radial Force 滾錐軸承 Taper Bearing	F_{2rB}	N	25~150	-	-	5,523 5,000(P)	9,100	12,320	14,420	18,620	24,080
容許軸向力 / Max. Axial Force 滾錐軸承 Taper Bearing	F_{2aB}	N	25~150	-	-	2,762 2,500(P)	4,550	6,160	7,210	9,310	12,040
使用壽命 / Service Life	L_H	hr	25~150	S5 周期運轉 : >30,000 (S1 連續運轉 : >15,000 hrs) S5 Cycle Operation: >30,000 (S1 Continuous Operation: >15,000 hrs)							
效 率 / Efficiency	η	%	25, 50	$\geq 92\%$							
			75, 100, 150	$\geq 90\%$							
使用溫度 / Operating Temperature		°C	25~150	-10°C ~ +90°C							
潤 滑 / Lubrication			25~150	全合成潤滑油 Synthetic Oil							
噪 音 值 / Noise Level		dB	25~150	≤ 67	≤ 67	≤ 69	≤ 69	≤ 71	≤ 71	≤ 72	≤ 72

註 : (P) 螺桿式 NOTE: (P) Ball Screw

轉動慣量 Mass Moments of Inertia (kgcm²)

速比 Ratio	55	75	90	115	130	140	160	190
25	0.39	1.15	1.18	4.9	4.99	7.99	8.27	8.75
50	0.36	1.05	1.06	4.07	4.09	6.31	6.36	6.45
75	0.35	0.94	0.96	3.17	3.24	4.04	4.23	4.56
100	0.34	0.93	0.94	3.12	3.14	3.87	3.92	4.01
150	0.33	0.92	0.93	3.08	3.06	3.73	3.68	3.59

HY-FO series

RATIO : 5.10.15 (單段 1-Stage)

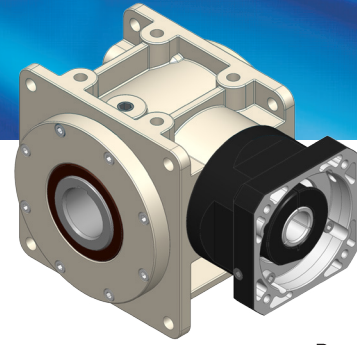

入力法蘭 - 出力中空軸

Input Flange - Hollow Output Shaft

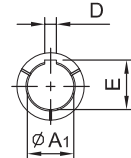
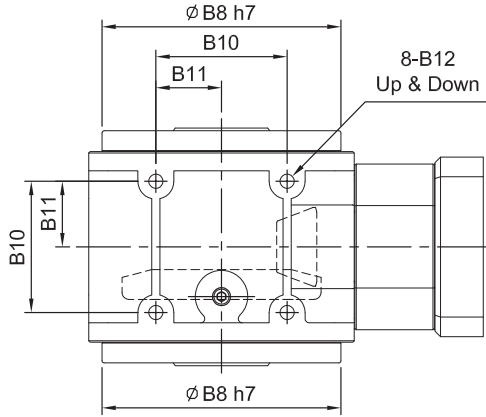

(入力孔$\phi 35$(含)以上)

$\phi A1$	D	E
$\phi 35$	10	38.3
$\phi 38$	10	41.3
$\phi 42$	12	45.3
$\phi 48$	14	51.8

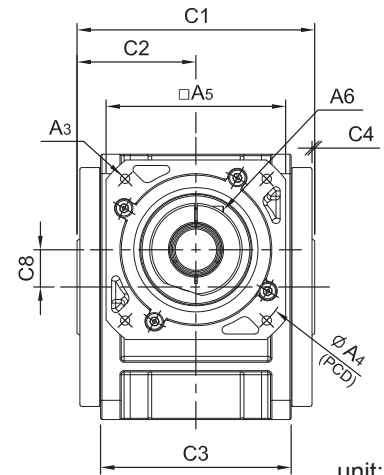
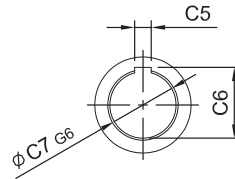
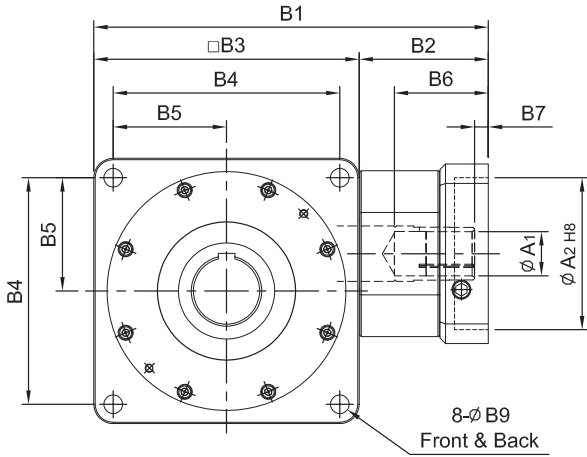

unit: mm

Model Code	55	75	90	115	130	140	160	190
A	A1 8・11	A1 14	A1 14・19	A1 19・24	A1 28・32	A1 35	A1 35・38	A1 42・48
	A2 30・40・50	A2 50・60・70	A2 50・70・80・95	A2 70・80・95・110	A2 95・110・130	A2 110・130・180	A2 110・130・180	A2 114.3・180・230・250
	A3 M3・M4・M5	A3 M4・M5・M6	A3 M5・M6	A3 M5・M6・M8	A3 M6・M8・M10	A3 M8・M10・M12	A3 M8・M10・M12	A3 M12・M16
	A4 46・60・63	A4 70・75・90	A4 70・90・100・115	A4 90・100・115・145	A4 115・145・165	A4 145・165・200	A4 145・165・200	A4 200・215・265・300
	A5 46・55	A5 64・70・80	A5 80・92・110	A5 92・110・130	A5 122・130・150	A5 146・150・190	A5 146・150・190	A5 182・200・250・265
	A6 M3 x P.05	A6 M5 x P0.8	A6 M5 x P0.8	A6 M6 x P1.0	A6 M8 x P1.25	A6 M10 x P1.5	A6 M10 x P1.5	A6 M10 x P1.5
B	B1 123	B1 158	B1 202	B1 241	B1 286	B1 333	B1 358	B1 417・419
	B2 33	B2 43	B2 62	B2 71	B2 94	B2 118	B2 118	B2 153・155
	B3 90	B3 115	B3 140	B3 170	B3 192	B3 215	B3 240	B3 264
	B4 78	B4 98	B4 118	B4 144	B4 164	B4 182	B4 206	B4 224
	B5 39	B5 49	B5 59	B5 72	B5 82	B5 91	B5 103	B5 112
	B6 26	B6 38	B6 49	B6 58	B6 69.5	B6 81.5	B6 81.5	B6 114.5・116.5
	B7 5	B7 6	B7 9	B7 8	B7 10	B7 10	B7 10	B7 11.5・13.5
	B8 84	B8 103	B8 128	B8 148	B8 173	B8 200	B8 227	B8 254
	B9 6.8	B9 9	B9 11	B9 11	B9 13.5	B9 15	B9 17.5	B9 17.5
	B10 44	B10 54	B10 66	B10 80	B10 95	B10 104	B10 120	B10 140
	B11 22	B11 27	B11 33	B11 40	B11 47.5	B11 52	B11 60	B11 70
	B12 M6 x P1.0	B12 M8 x P1.25	B12 M10 x P1.5	B12 M12 x P1.75	B12 M12 x P1.75	B12 M14 x P2.0	B12 M16 x P2.0	B12 M16 x P2.0
C	C1 88	C1 108	C1 132	C1 156	C1 172	C1 187	C1 212	C1 242
	C2 44	C2 54	C2 66	C2 78	C2 86	C2 93.5	C2 106	C2 121
	C3 60	C3 80	C3 100	C3 120	C3 138	C3 146	C3 166	C3 196
	C4 2	C4 2	C4 2	C4 2	C4 2	C4 2	C4 2	C4 2
	C5 6	C5 7	C5 8	C5 10	C5 12	C5 14	C5 14	C5 18
	C6 22.8	C6 28.3	C6 33.3	C6 43.3	C6 51.3	C6 58.8	C6 63.8	C6 74.3
	C7 20	C7 25	C7 30	C7 40	C7 48	C7 55	C7 60	C7 70
	C8 9	C8 14	C8 18	C8 23	C8 27	C8 32	C8 38	C8 42
Weight	重量 3.0	重量 4.6	重量 8.3	重量 12.3	重量 18.2	重量 26.6	重量 37.6	重量 59.5

HY-RO series

RATIO : 25.50.75.100.150 (雙段 2-Stage)

搭配行星減速機 - 出力中空軸

Fitted with Planetary Reducer - Hollow Output Shaft

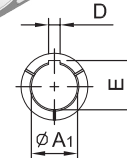
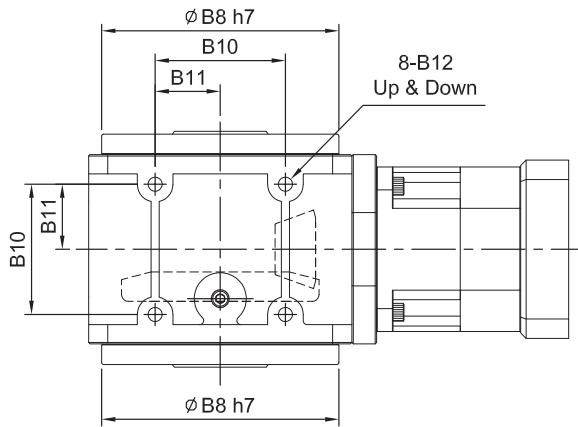
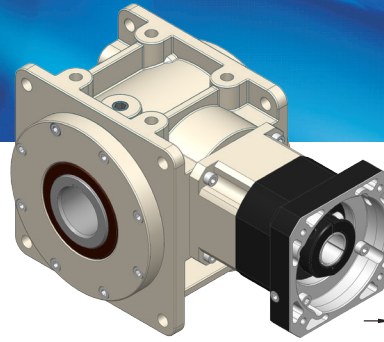

(入力孔 $\phi 38$ (含)以上)

$\phi A1$	D	E
$\phi 38$	10	41.3
$\phi 42$	12	45.3
$\phi 48$	14	51.8
$\phi 55$	16	59.3

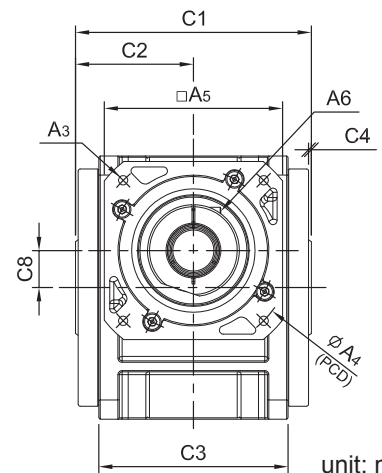
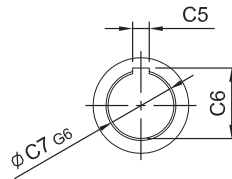
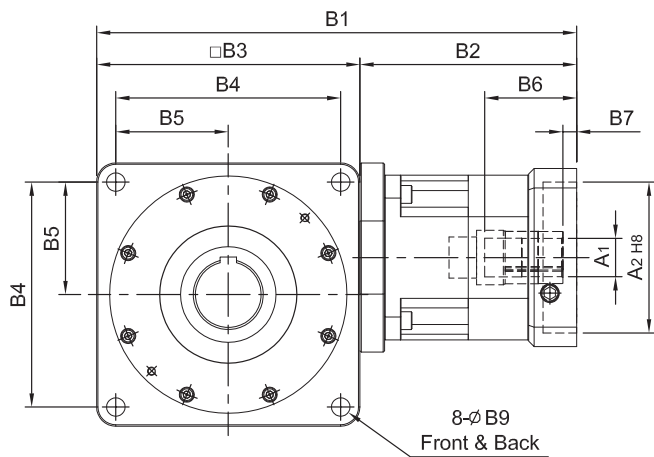

unit: mm

Model Code	55	75	90	115	130	140	160	190	
A	A1	8 · 11	14	(14) · 19	19 · 24	28 · 32	32 · 35	38 · 42 · 48 · 55	
	A2	30 · 40 · 50	50 · 60 · 70	50 · 70 · 80 · 95	70 · 80 · 95 · 110	95 · 110 · 130	110 · 130 · 180	114.3 · 180 · 230 · 250	
	A3	M3 · M4 · M5	M4 · M5 · M6	M5 · M6	M5 · M6 · M8	M6 · M8 · M10	M8 · M10 · M12	M8 · M10 · M12	M12 · M16
	A4	46 · 60 · 63	70 · 75 · 90	70 · 90 · 100 · 115	90 · 100 · 115 · 145	115 · 145 · 165	145 · 165 · 200	145 · 165 · 200	200 · 215 · 265 · 300
	A5	46 · 55	64 · 70 · 80	80 · 92 · 110	92 · 110 · 130	122 · 130 · 150	146 · 150 · 190	146 · 150 · 190	182 · 200 · 250 · 265
	A6	M3 x P.05	M5 x P0.8	M5 x P0.8	M6 x P1.0	M8 x P1.25	M10 x P1.5	M10 x P1.5	M10 x P1.5
B	B1	157	201	(224.5) · 237	287	340	405	508 · 510	
	B2	67	86	(84.5) · 97	117	148	190	244 · 246	
	B3	90	115	140	170	192	215	264	
	B4	78	98	118	144	164	182	224	
	B5	39	49	59	72	82	91	112	
	B6	26	32	(33.5) · 45.5	59	67	84.5	114.5 · 116.5	
	B7	5	6	(6) · 10	9	10	10	11.5 · 13.5	
	B8	84	103	128	148	173	200	254	
	B9	6.8	9	11	11	13.5	15	17.5	
	B10	44	54	66	80	95	104	140	
	B11	22	27	33	40	47.5	52	70	
	B12	M6 x P1.0	M8 x P1.25	M10 x P1.5	M12 x P1.75	M12 x P1.75	M14 x P2.0	M16 x P2.0	M16 x P2.0
C	C1	88	108	132	156	172	212	242	
	C2	44	54	66	78	86	93.5	121	
	C3	60	80	100	120	138	146	196	
	C4	2	2	2	2	2	2	2	
	C5	6	7	8	10	12	14	18	
	C6	22.8	28.3	33.3	43.3	51.3	58.8	74.3	
	C7	20	25	30	40	48	55	70	
	C8	9	14	18	23	27	32	42	
Weight	重量	3.5	5.8	10.0	16.0	26.8	41.2	86.1	

HY-DO series

RATIO : 5.10.15 (單段 1-Stage)

單入力軸心 - 出力中空軸

Single Input Shaft - Hollow Output Shaft

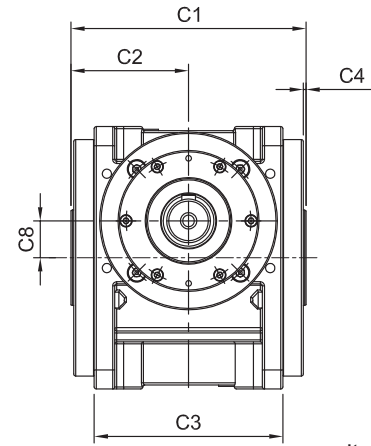
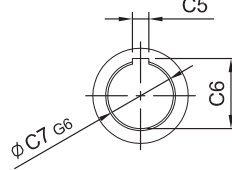
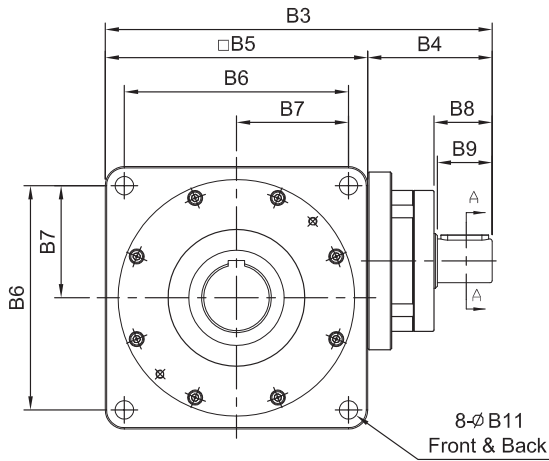
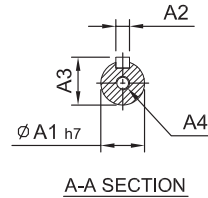
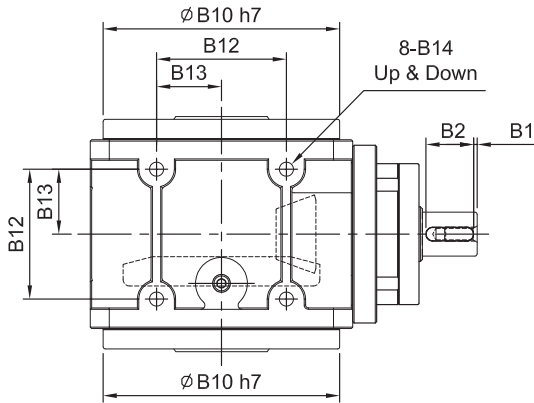
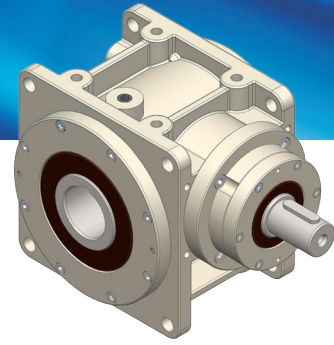

unit: mm

Model Code	55	75	90	115	130	140	160	190																																																																																																																						
	A	A1: 14	A2: 5	A3: 16	A4: M5 x P0.8	A1: 14	A2: 6	A3: 21.5	A4: M6 x P1.0	A1: 19	A2: 8	A3: 27	A4: M8 x P1.25	A1: 28	A2: 8	A3: 31	A4: M10 x P1.5	A1: 32	A2: 10	A3: 35	A4: M10 x P1.5	A1: 32	A2: 10	A3: 35	A4: M10 x P1.5	A1: 38	A2: 12	A3: 41	A4: M12 x P1.75	A1: 40	A2: 12	A3: 43	A4: M12 x P1.75																																																																																													
B	B1: 2.5	B2: 20	B3: 147	B4: 57	B5: 90	B6: 78	B7: 39	B8: 27	B9: 25	B10: 84	B11: 6.8	B12: 44	B13: 22	B14: M6 x P1.0	B1: 2.5	B2: 25	B3: 181	B4: 66	B5: 115	B6: 98	B7: 49	B8: 32	B9: 30	B10: 103	B11: 9	B12: 54	B13: 27	B14: M8 x P1.25	B1: 2.5	B2: 35	B3: 218	B4: 78	B5: 140	B6: 118	B7: 59	B8: 42.5	B9: 40	B10: 128	B11: 11	B12: 66	B13: 33	B14: M10 x P1.5	B1: 2.5	B2: 35	B3: 260	B4: 90	B5: 170	B6: 144	B7: 72	B8: 42.5	B9: 40	B10: 148	B11: 11	B12: 80	B13: 40	B14: M12 x P1.75	B1: 5	B2: 40	B3: 293	B4: 101	B5: 192	B6: 164	B7: 82	B8: 52.5	B9: 50	B10: 173	B11: 13.5	B12: 95	B13: 47.5	B14: M12 x P1.75	B1: 5	B2: 40	B3: 315	B4: 100	B5: 215	B6: 182	B7: 91	B8: 51.5	B9: 50	B10: 200	B11: 15	B12: 104	B13: 52	B14: M14 x P2.0	B1: 5	B2: 40	B3: 367	B4: 127	B5: 240	B6: 206	B7: 103	B8: 63	B9: 60	B10: 227	B11: 17.5	B12: 120	B13: 60	B14: M16 x P2.0	B1: 5	B2: 50	B3: 403	B4: 139	B5: 264	B6: 224	B7: 112	B8: 63.5	B9: 60	B10: 254	B11: 17.5	B12: 140	B13: 70	B14: M16 x P2.0	B1: 5	B2: 50	B3: 403	B4: 139	B5: 264	B6: 224	B7: 112	B8: 63.5	B9: 60	B10: 254	B11: 17.5	B12: 140	B13: 70	B14: M16 x P2.0
C	C1: 88	C2: 44	C3: 60	C4: 2	C5: 6	C6: 22.8	C7: 20	C8: 9	C1: 108	C2: 54	C3: 80	C4: 2	C5: 7	C6: 28.3	C7: 25	C8: 14	C1: 132	C2: 66	C3: 100	C4: 2	C5: 8	C6: 33.3	C7: 30	C8: 18	C1: 156	C2: 78	C3: 120	C4: 2	C5: 10	C6: 43.3	C7: 40	C8: 23	C1: 172	C2: 86	C3: 138	C4: 2	C5: 12	C6: 51.3	C7: 48	C8: 27	C1: 187	C2: 93.5	C3: 146	C4: 2	C5: 14	C6: 58.8	C7: 55	C8: 32	C1: 212	C2: 106	C3: 166	C4: 2	C5: 14	C6: 63.8	C7: 60	C8: 38	C1: 242	C2: 121	C3: 196	C4: 2	C5: 18	C6: 74.3	C7: 70	C8: 42	C1: 242	C2: 121	C3: 196	C4: 2	C5: 18	C6: 74.3	C7: 70	C8: 42	C1: 242	C2: 121	C3: 196	C4: 2	C5: 18	C6: 74.3	C7: 70	C8: 42																																														
Weight	2.9	4.6	8.1	11.0	18.7	25.9	36.8	56.1	2.9	4.6	8.1	11.0	18.7	25.9	36.8	56.1	2.9	4.6	8.1	11.0	18.7	25.9	36.8	56.1	2.9	4.6	8.1	11.0	18.7	25.9	36.8	56.1	2.9	4.6	8.1	11.0	18.7	25.9	36.8	56.1	2.9	4.6	8.1	11.0	18.7	25.9	36.8	56.1	2.9	4.6	8.1	11.0	18.7	25.9	36.8	56.1																																																																						

HY-FN series

RATIO : 5.10.15 (單段 1-Stage)

入力法蘭 - 單邊免鍵軸套

Input Flange - Single Clamping

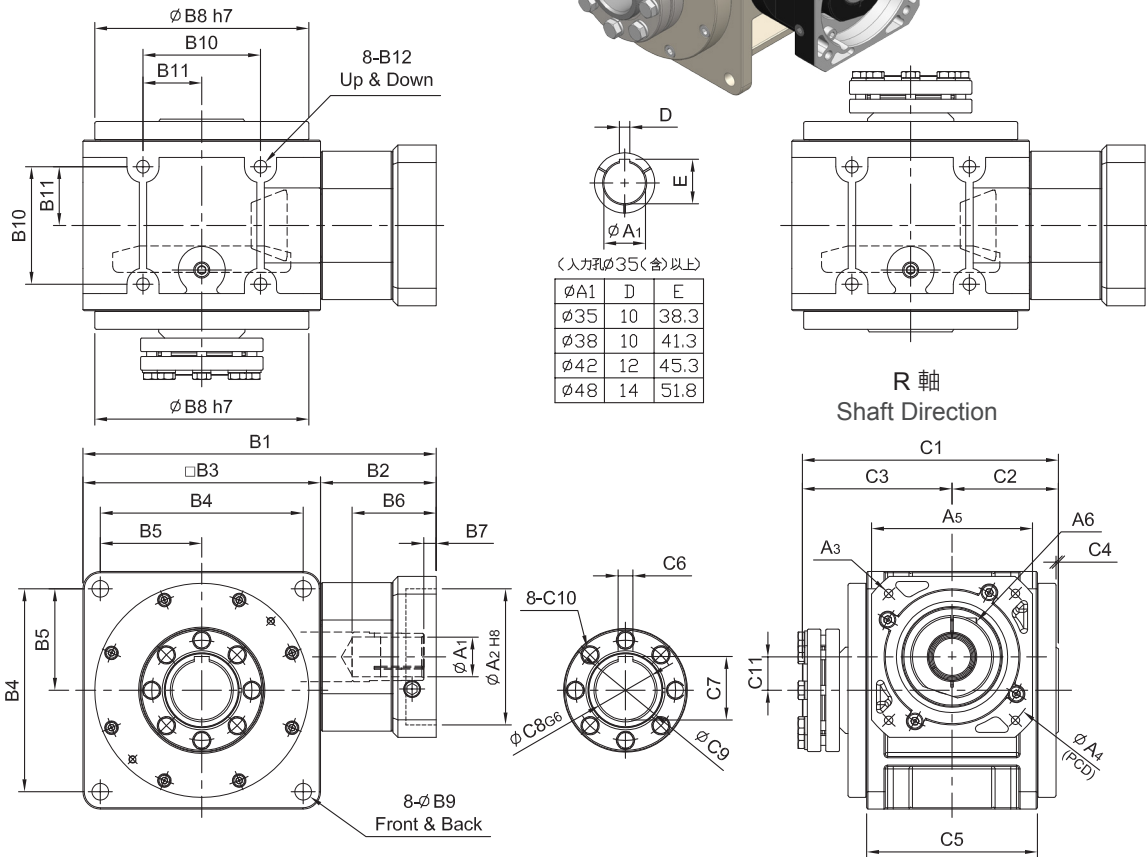
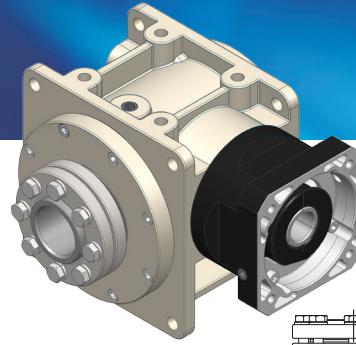

unit: mm

Model Code	55	75	90	115	130	140	160	190	
A	A1	8 · 11	14	14 · 19	19 · 24	28 · 32	35	35 · 38	42 · 48
	A2	30 · 40 · 50	50 · 60 · 70	50 · 70 · 80 · 95	70 · 80 · 95 · 110	95 · 110 · 130	110 · 130 · 180	110 · 130 · 180	114.3 · 180 · 230 · 250
	A3	M3 · M4 · M5	M4 · M5 · M6	M5 · M6	M5 · M6 · M8	M6 · M8 · M10	M8 · M10 · M12	M8 · M10 · M12	M12 · M16
	A4	46 · 60 · 63	70 · 75 · 90	70 · 90 · 100 · 115	90 · 100 · 115 · 145	115 · 145 · 165	145 · 165 · 200	145 · 165 · 200	200 · 215 · 265 · 300
	A5	46 · 55	64 · 70 · 80	80 · 92 · 110	92 · 110 · 130	122 · 130 · 150	146 · 150 · 190	146 · 150 · 190	182 · 200 · 250 · 265
	A6	M3 x P.05	M5 x P0.8	M5 x P0.8	M6 x P1.0	M8 x P1.25	M10 x P1.5	M10 x P1.5	M10 x P1.5
B	B1	123	158	202	241	286	333	358	417 · 419
	B2	33	43	62	71	94	118	118	153 · 155
	B3	90	115	140	170	192	215	240	264
	B4	78	98	118	144	164	182	206	224
	B5	39	49	59	72	82	91	103	112
	B6	26	38	49	58	69.5	81.5	81.5	114.5 · 116.5
	B7	5	6	9	8	10	10	10	11.5 · 13.5
	B8	84	103	128	148	173	200	227	254
	B9	6.8	9	11	11	13.5	15	17.5	17.5
	B10	44	54	66	80	95	104	120	140
	B11	22	27	33	40	47.5	52	60	70
	B12	M6 x P1.0	M8 x P1.25	M10 x P1.5	M12 x P1.75	M12 x P1.75	M14 x P2.0	M16 x P2.0	M16 x P2.0
C	C1	109	134	160	189	207	224	249	281
	C2	44	54	66	78	86	93.5	106	121
	C3	65	80	94	111	121	130.5	143	160
	C4	2	2	2	2	2	2	2	2
	C5	60	80	100	120	138	146	166	196
	C6	6	7	8	10	12	14	14	18
	C7	22.8	28.3	33.3	43.3	51.3	58.8	63.8	74.3
	C8	20	25	30	40	48	55	60	70
	C9	28	34	44	52	60	65	73	83
	C10	M6	M6	M6	M8	M8	M8	M8	M10
	C11	9	14	18	23	27	32	38	42
Weight	重量	3.2	5.0	8.7	13.0	19.3	27.4	39.4	61.7

HY-RN series

RATIO : 25.50.75.100.150 (雙段 2-Stage)

搭配行星減速機 - 單邊免鍵軸套

Fitted with Planetary Reducer - Single Clamping

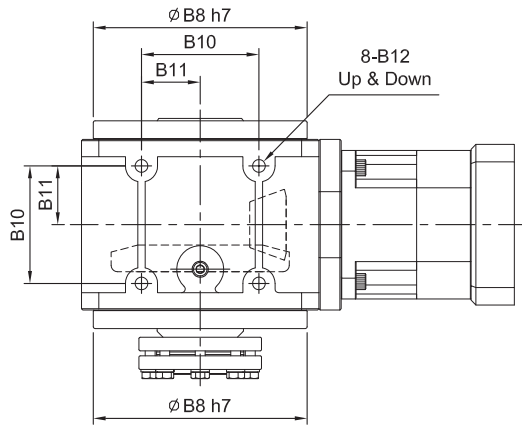
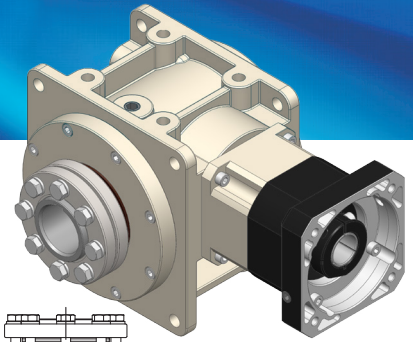

(入力孔φ38(含)以上)

φA1	D	E
φ38	10	41.3
φ42	12	45.3
φ48	14	51.8
φ55	16	59.3

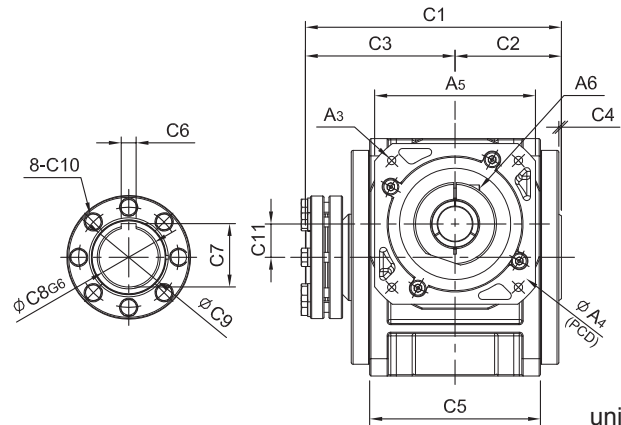
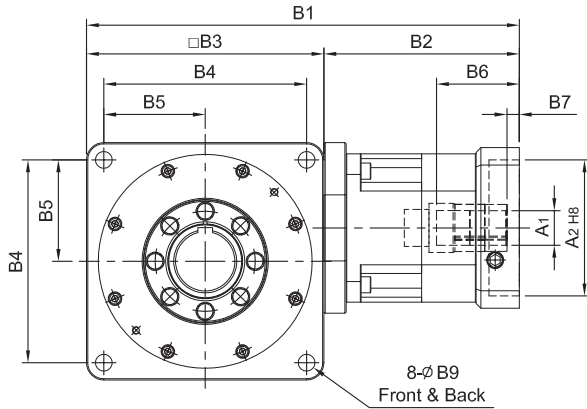
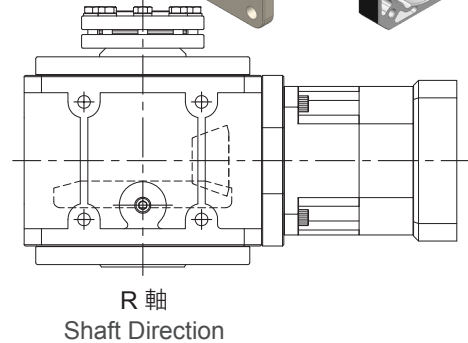

unit: mm

Model Code	55	75	90	115	130	140	160	190	
A	A1	8 · 11	14	(14) · 19	19 · 24	28 · 32	32 · 35	32 · 35	38 · 42 · 48 · 55
	A2	30 · 40 · 50	50 · 60 · 70	50 · 70 · 80 · 95	70 · 80 · 95 · 110	95 · 110 · 130	110 · 130 · 180	110 · 130 · 180	114.3 · 180 · 230 · 250
	A3	M3 · M4 · M5	M4 · M5 · M6	M5 · M6	M5 · M6 · M8	M6 · M8 · M10	M8 · M10 · M12	M8 · M10 · M12	M12 · M16
	A4	46 · 60 · 63	70 · 75 · 90	70 · 90 · 100 · 115	90 · 100 · 115 · 145	115 · 145 · 165	145 · 165 · 200	145 · 165 · 200	200 · 215 · 265 · 300
	A5	46 · 55	64 · 70 · 80	80 · 92 · 110	92 · 110 · 130	122 · 130 · 150	146 · 150 · 190	146 · 150 · 190	182 · 200 · 250 · 265
	A6	M3 x P.05	M5 x P0.8	M5 x P0.8	M6 x P1.0	M8 x P1.25	M10 x P1.5	M10 x P1.5	M10 x P1.5
B	B1	157	201	(224.5) · 237	287	340	405	430	508 · 510
	B2	67	86	(84.5) · 97	117	148	190	190	244 · 246
	B3	90	115	140	170	192	215	240	264
	B4	78	98	118	144	164	182	206	224
	B5	39	49	59	72	82	91	103	112
	B6	26	32	(33.5) · 45.5	59	67	84.5	84.5	114.5 · 116.5
	B7	5	6	(6) · 10	9	10	10	10	11.5 · 13.5
	B8	84	103	128	148	173	200	227	254
	B9	6.8	9	11	11	13.5	15	17.5	17.5
	B10	44	54	66	80	95	104	120	140
	B11	22	27	33	40	47.5	52	60	70
	B12	M6 x P1.0	M8 x P1.25	M10 x P1.5	M12 x P1.75	M12 x P1.75	M14 x P2.0	M16 x P2.0	M16 x P2.0
C	C1	109	134	160	189	207	224	249	281
	C2	44	54	66	78	86	93.5	106	121
	C3	65	80	94	111	121	130.5	143	160
	C4	2	2	2	2	2	2	2	2
	C5	60	80	100	120	138	146	166	196
	C6	6	7	8	10	12	14	14	18
	C7	22.8	28.3	33.3	43.3	51.3	58.8	63.8	74.3
	C8	20	25	30	40	48	55	60	70
	C9	28	34	44	52	60	65	73	83
	C10	M6	M6	M6	M8	M8	M8	M8	M10
	C11	9	14	18	23	27	32	38	42
Weight	重量	3.8	6.2	10.5	16.7	28.0	41.9	53.9	88.4

HY-DN series

RATIO : 5.10.15 (單段 1-Stage)

單入力軸心 - 單邊免鍵軸套

Single Input Shaft - Single Clamping

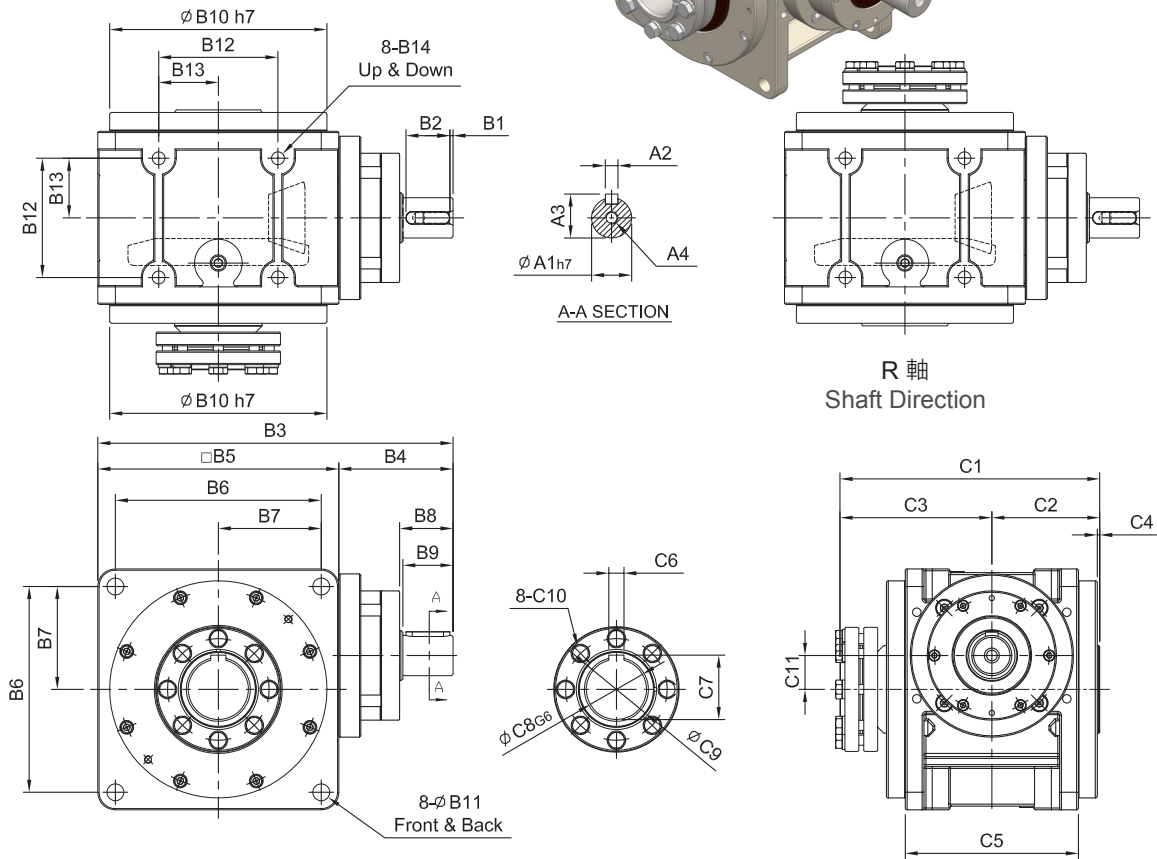
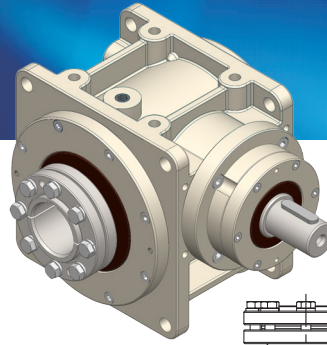

unit: mm

Model Code	55	75	90	115	130	140	160	190	
	A	A1	14	19	24	28	32	32	38
	A2	5	6	8	8	10	10	12	12
	A3	16	21.5	27	31	35	35	41	43
	A4	M5 x P0.8	M6 x P1.0	M8 x P1.25	M10 x P1.5	M10 x P1.5	M10 x P1.5	M12 x P1.75	M12 x P1.75
B	B1	2.5	2.5	2.5	2.5	5	5	5	5
	B2	20	25	35	35	40	40	50	50
	B3	147	181	218	260	293	315	367	403
	B4	57	66	78	90	101	100	127	139
	B5	90	115	140	170	192	215	240	264
	B6	78	98	118	144	164	182	206	224
	B7	39	49	59	72	82	91	103	112
	B8	27	32	42.5	42.5	52.5	51.5	63	63.5
	B9	25	30	40	40	50	50	60	60
	B10	84	103	128	148	173	200	227	254
	B11	6.8	9	11	11	13.5	15	17.5	17.5
	B12	44	54	66	80	95	104	120	140
	B13	22	27	33	40	47.5	52	60	70
	B14	M6 x P1.0	M8 x P1.25	M10 x P1.5	M12 x P1.75	M12 x P1.75	M14 x P2.0	M16 x P2.0	M16 x P2.0
C	C1	109	134	160	189	207	224	249	281
	C2	44	54	66	78	86	93.5	106	121
	C3	65	80	94	111	121	130.5	143	160
	C4	2	2	2	2	2	2	2	2
	C5	60	80	100	120	138	146	166	196
	C6	6	7	8	10	12	14	14	18
	C7	22.8	28.3	33.3	43.3	51.3	58.8	63.8	74.3
	C8	20	25	30	40	48	55	60	70
	C9	28	34	44	52	60	65	73	83
	C10	M6	M6	M6	M8	M8	M8	M8	M10
	C11	9	14	18	23	27	32	38	42
Weight	重量	3.1	5.0	8.6	11.6	19.9	27.8	38.6	58.4

HY-FM series

RATIO : 5.10.15 (單段 1-Stage)

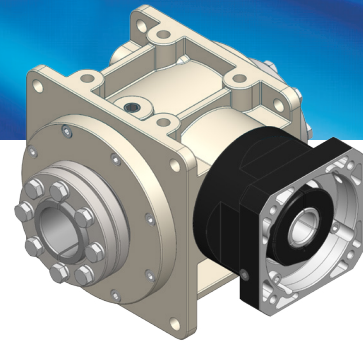

入力法蘭 - 雙邊免鍵軸套

Input Flange - Double Clamping

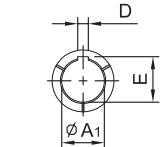
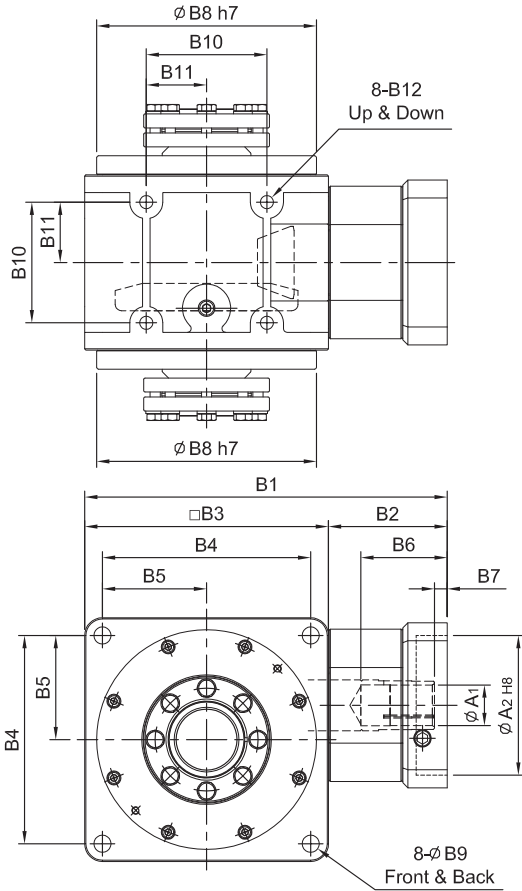

(入力孔φ35(含)以上)

φA1	D	E
φ35	10	38.3
φ38	10	41.3
φ42	12	45.3
φ48	14	51.8

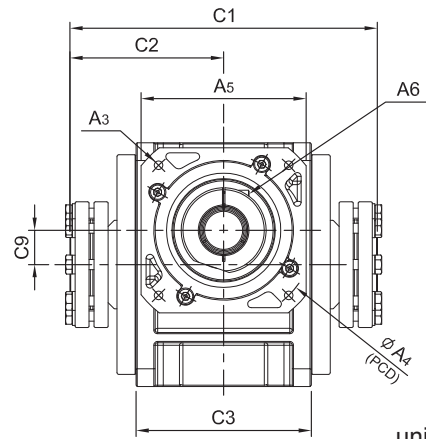
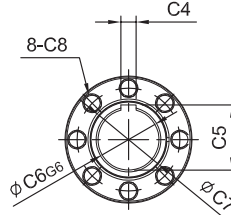

unit: mm

Model Code	55	75	90	115	130	140	160	190	
A	A1	8 · 11	14	14 · 19	19 · 24	28 · 32	35	35 · 38	42 · 48
	A2	30 · 40 · 50	50 · 60 · 70	50 · 70 · 80 · 95	70 · 80 · 95 · 110	95 · 110 · 130	110 · 130 · 180	110,130,180	114.3 · 180 · 230 · 250
	A3	M3 · M4 · M5	M4 · M5 · M6	M5 · M6	M5 · M6 · M8	M6 · M8 · M10	M8 · M10 · M12	M8 · M10 · M12	M12 · M16
	A4	46 · 60 · 63	70 · 75 · 90	70 · 90 · 100 · 115	90 · 100 · 115 · 145	115 · 145 · 165	145 · 165 · 200	145 · 165 · 200	200 · 215 · 265 · 300
	A5	46 · 55	64 · 70 · 80	80 · 92 · 110	92 · 110 · 130	122 · 130 · 150	146 · 150 · 190	146 · 150 · 190	182 · 200 · 250 · 265
	A6	M3 x P.05	M5 x P0.8	M5 x P0.8	M6 x P1.0	M8 x P1.25	M10 x P1.5	M10 x P1.5	M10 x P1.5
B	B1	123	158	202	241	286	333	358	417 · 419
	B2	33	43	62	71	94	118	118	153 · 155
	B3	90	115	140	170	192	215	240	264
	B4	78	98	118	144	164	182	206	224
	B5	39	49	59	72	82	91	103	112
	B6	26	38	49	58	69.5	81.5	81.5	114.5 · 116.5
	B7	5	6	9	8	10	10	10	11.5 · 13.5
	B8	84	103	128	148	173	200	227	254
	B9	6.8	9	11	11	13.5	15	17.5	17.5
	B10	44	54	66	80	95	104	120	140
	B11	22	27	33	40	47.5	52	60	70
	B12	M6 x P1.0	M8 x P1.25	M10 x P1.5	M12 x P1.75	M12 x P1.75	M14 x P2.0	M16 x P2.0	M16 x P2.0
C	C1	130	160	188	222	242	261	286	320
	C2	65	80	94	111	121	130.5	143	160
	C3	60	80	100	120	138	146	166	196
	C4	-	-	-	-	12	14	14	18
	C5	-	-	-	-	51.3	58.8	63.8	74.3
	C6	20	25	30	40	48	55	60	70
	C7	28	34	44	52	60	65	73	83
	C8	M6	M6	M6	M8	M8	M8	M8	M10
	C9	9	14	18	23	27	32	38	42
Weight	重量	3.5	5.3	9.2	13.7	20.5	28.6	41.0	64.0

HY-RM series

RATIO : 25.50.75.100.150 (雙段 2-Stage)

搭配行星減速機 - 雙邊免鍵軸套

Fitted with Planetary Reducer - Double Clamping

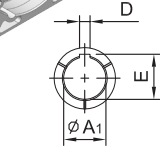
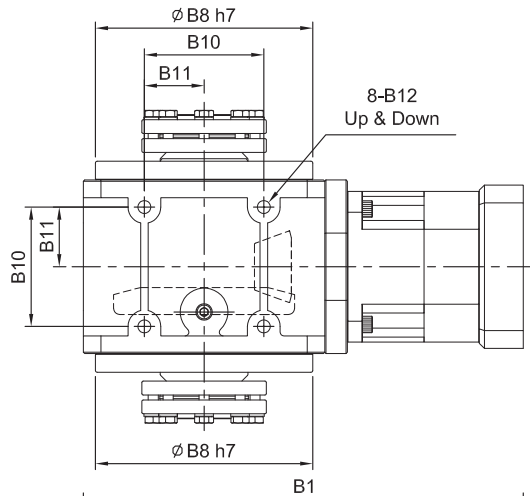
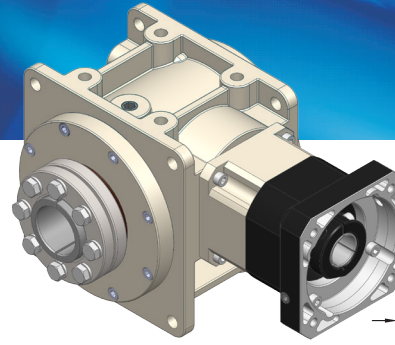

(入力径φ38(含)以上)

φA1	D	E
φ38	10	41.3
φ42	12	45.3
φ48	14	51.8
φ55	16	59.3

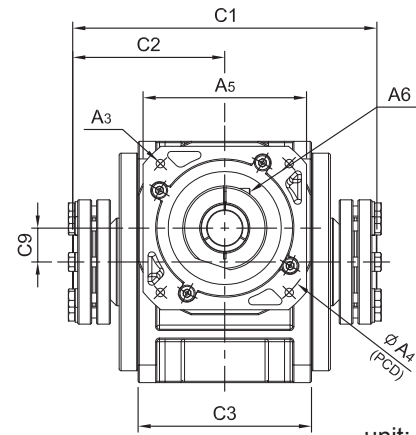
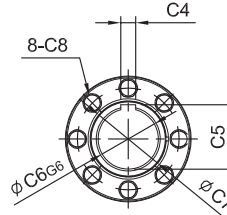
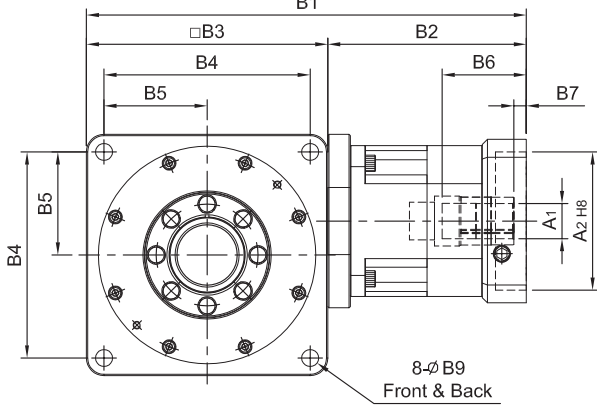

unit: mm

Model Code	55	75	90	115	130	140	160	190	
A	A1	8 · 11	14	(14) · 19	19 · 24	28 · 32	32 · 35	32 · 35	38 · 42 · 48 · 55
	A2	30 · 40 · 50	50 · 60 · 70	50 · 70 · 80 · 95	70 · 80 · 95 · 110	95 · 110 · 130	110 · 130 · 180	110 · 130 · 180	114.3 · 180 · 230 · 250
	A3	M3 · M4 · M5	M4 · M5 · M6	M5 · M6	M5 · M6 · M8	M6 · M8 · M10	M8 · M10 · M12	M8 · M10 · M12	M12 · M16
	A4	46 · 60 · 63	70 · 75 · 90	70 · 90 · 100 · 115	90 · 100 · 115 · 145	115 · 145 · 165	145 · 165 · 200	145 · 165 · 200	200 · 215 · 265 · 300
	A5	46 · 55	64 · 70 · 80	80 · 92 · 110	92 · 110 · 130	122 · 130 · 150	146 · 150 · 190	146 · 150 · 190	182 · 200 · 250 · 265
	A6	M3 x P.05	M5 x P.0.8	M5 x P.0.8	M6 x P1.0	M8 x P1.25	M10 x P1.5	M10 x P1.5	M10 x P1.5
B	B1	157	201	(224.5) · 237	287	340	405	430	508 · 510
	B2	67	86	(84.5) · 97	117	148	190	190	244 · 246
	B3	90	115	140	170	192	215	240	264
	B4	78	98	118	144	164	182	206	224
	B5	39	49	59	72	82	91	103	112
	B6	26	32	(33.5) · 45.5	59	67	84.5	84.5	114.5 · 116.5
	B7	5	6	(6) · 10	9	10	10	10	11.5 · 13.5
	B8	84	103	128	148	173	200	227	254
	B9	6.8	9	11	11	13.5	15	17.5	17.5
	B10	44	54	66	80	95	104	120	140
	B11	22	27	33	40	47.5	52	60	70
	B12	M6 x P1.0	M8 x P1.25	M10 x P1.5	M12 x P1.75	M12 x P1.75	M14 x P2.0	M16 x P2.0	M16 x P2.0
C	C1	130	160	188	222	242	261	286	320
	C2	65	80	94	111	121	130.5	143	160
	C3	60	80	100	120	138	146	166	196
	C4	-	-	-	-	12	14	14	18
	C5	-	-	-	-	51.3	58.8	63.8	74.3
	C6	20	25	30	40	48	55	60	70
	C7	28	34	44	52	60	65	73	83
	C8	M6	M6	M6	M8	M8	M8	M8	M10
	C9	9	14	18	23	27	32	38	42
Weight	重量	4.1	6.6	11.0	17.4	29.1	43.1	55.6	90.7

HY-DM series

RATIO : 5.10.15 (單段 1-Stage)

單入力軸心 - 雙邊免鍵軸套

Single Input Shaft - Double Clamping

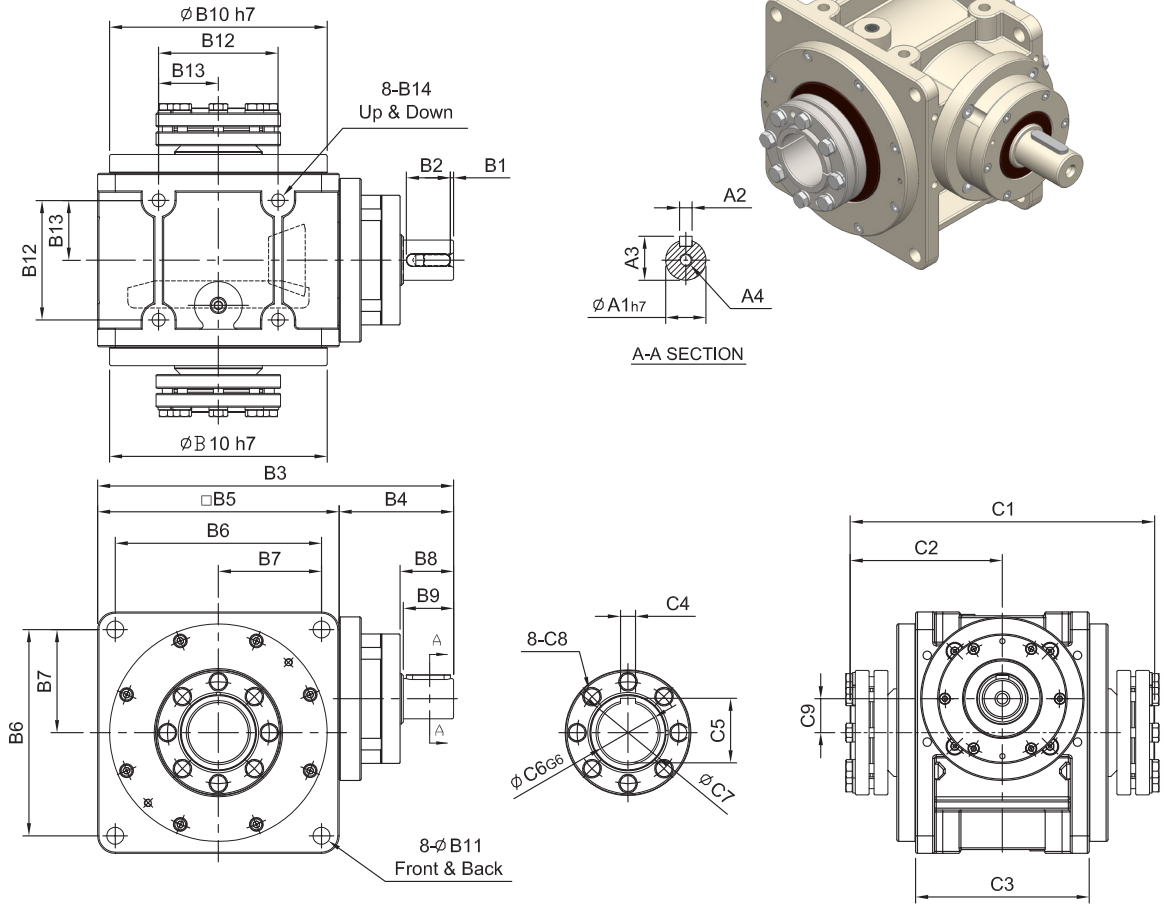

unit: mm

Model Code	55	75	90	115	130	140	160	190	
	A								
A1	14	19	24	28	32	32	38	40	
A2	5	6	8	8	10	10	12	12	
A3	16	21.5	27	31	35	35	41	43	
A4	M5 x P0.8	M6 x P1.0	M8 x P1.25	M10 x P1.5	M10 x P1.5	M10 x P1.5	M12 x P1.75	M12 x P1.75	
B									
B1	2.5	2.5	2.5	2.5	5	5	5	5	
B2	20	25	35	35	40	40	50	50	
B3	147	181	218	260	293	315	367	403	
B4	57	66	78	90	101	100	127	139	
B5	90	115	140	170	192	215	240	264	
B6	78	98	118	144	164	182	206	224	
B7	39	49	59	72	82	91	103	112	
B8	27	32	42.5	42.5	52.5	51.5	63	63.5	
B9	25	30	40	40	50	50	60	60	
B10	84	103	128	148	173	200	227	254	
B11	6.8	9	11	11	13.5	15	17.5	17.5	
B12	44	54	66	80	95	104	120	140	
B13	22	27	33	40	47.5	52	60	70	
B14	M6 x P1.0	M8 x P1.25	M10 x P1.5	M12 x P1.75	M12 x P1.75	M14 x P2.0	M16 x P2.0	M16 x P2.0	
C									
C1	130	160	188	222	242	261	286	320	
C2	65	80	94	111	121	130.5	143	160	
C3	60	80	100	120	138	146	166	196	
C4	-	-	-	-	12	14	14	18	
C5	-	-	-	-	51.3	58.8	63.8	74.3	
C6	20	25	30	40	48	55	60	70	
C7	28	34	44	52	60	65	73	83	
C8	M6	M6	M6	M8	M8	M8	M8	M10	
C9	9	14	18	23	27	32	38	42	
Weight	重量	3.4	5.3	8.9	11.9	20.7	29.7	41	60.7

HY-FS series

RATIO : 5.10.15 (單段 1-Stage)

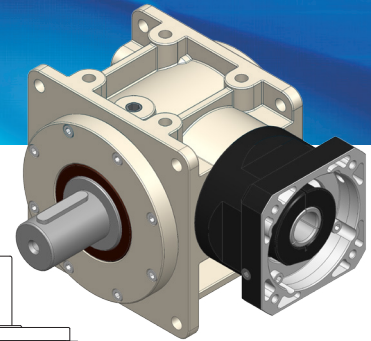

入力法蘭 - 單出力軸心

Input Flange - Single Output Shaft

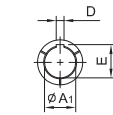
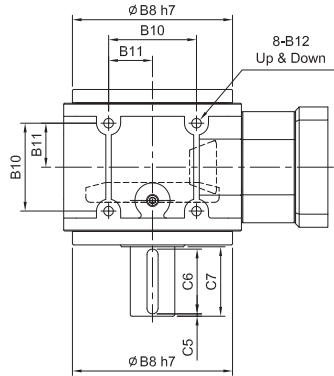

(入力径φ35(含)以上)

φA1	D	E
φ35	10	38.3
φ38	10	41.3
φ42	12	45.3
φ48	14	51.8

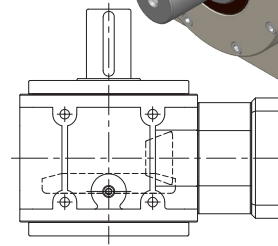

R 軸
Shaft Direction

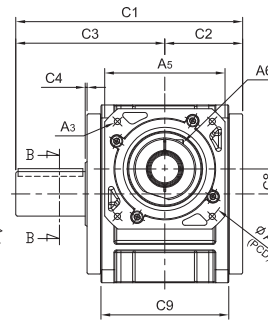
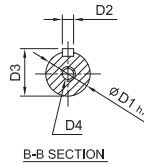
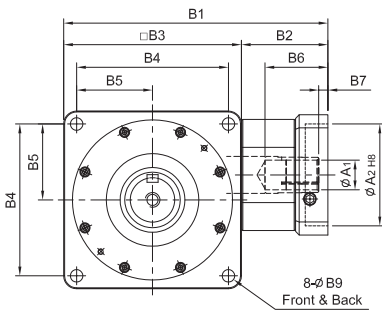

unit: mm

Model Code	55	75	90	115	130	140	160	190
	A	A1 8 · 11 A2 30 · 40 · 50 A3 M3 · M4 · M5 A4 46 · 60 · 63 A5 46 · 55 A6 M3 x P.05	A1 14 A2 50 · 60 · 70 A3 M4 · M5 · M6 A4 70 · 75 · 90 A5 64 · 70 · 80 A6 M5 x P0.8	A1 14 · 19 A2 50 · 70 · 80 · 95 A3 M5 · M6 A4 70 · 90 · 100 · 115 A5 80 · 92 · 110 A6 M5 x P0.8	A1 19 · 24 A2 70 · 80 · 95 · 110 A3 M5 · M6 · M8 A4 90 · 100 · 115 · 145 A5 92 · 110 · 130 A6 M6 x P1.0	A1 28 · 32 A2 95 · 110 · 130 A3 M6 · M8 · M10 A4 115 · 145 · 165 A5 122 · 130 · 150 A6 M8 x P1.25	A1 35 A2 110 · 130 · 180 A3 M8 · M10 · M12 A4 145 · 165 · 200 A5 146 · 150 · 190 A6 M10 x P1.5	A1 35 · 38 A2 110 · 130 · 180 A3 M8 · M10 · M12 A4 145 · 165 · 200 A5 146 · 150 · 190 A6 M10 x P1.5
B	B1 123 B2 33 B3 90 B4 78 B5 39 B6 26 B7 5 B8 84 B9 6.8 B10 44 B11 22 B12 M6 x P1.0	B1 158 B2 43 B3 115 B4 98 B5 49 B6 38 B7 6 B8 103 B9 9 B10 54 B11 27 B12 M8 x P1.25	B1 202 B2 62 B3 140 B4 118 B5 59 B6 49 B7 9 B8 128 B9 11 B10 66 B11 33 B12 M10 x P1.5	B1 241 B2 71 B3 170 B4 144 B5 72 B6 58 B7 8 B8 148 B9 11 B10 80 B11 40 B12 M12 x P1.75	B1 286 B2 94 B3 192 B4 164 B5 82 B6 69.5 B7 10 B8 173 B9 13.5 B10 95 B11 47.5 B12 M12 x P1.75	B1 333 B2 118 B3 215 B4 182 B5 91 B6 81.5 B7 10 B8 200 B9 15 B10 104 B11 52 B12 M14 x P2.0	B1 358 B2 118 B3 240 B4 206 B5 103 B6 81.5 B7 10 B8 227 B9 17.5 B10 120 B11 60 B12 M16 x P2.0	B1 417 · 419 B2 153 · 155 B3 264 B4 224 B5 112 B6 114.5 · 116.5 B7 11.5 · 13.5 B8 254 B9 17.5 B10 140 B11 70 B12 M16 x P2.0
C	C1 121 C2 42 C3 79 C4 2 C5 5 C6 25 C7 35 C8 9 C9 60	C1 146 C2 52 C3 94 C4 2 C5 5 C6 30 C7 40 C8 14 C9 80	C1 180 C2 64 C3 120 C4 2 C5 5 C6 40 C7 50 C8 18 C9 100	C1 214 C2 76 C3 138 C4 2 C5 5 C6 50 C7 60 C8 23 C9 120	C1 245 C2 84 C3 161 C4 2 C5 5 C6 65 C7 75 C8 27 C9 138	C1 275 C2 91.5 C3 183.5 C4 2 C5 5 C6 80 C7 90 C8 32 C9 146	C1 310 C2 103 C3 206 C4 2 C5 5 C6 90 C7 100 C8 38 C9 166	C1 350 C2 118 C3 231 C4 2 C5 5 C6 100 C7 110 C8 42 C9 196
D	D1 20 D2 6 D3 22.5 D4 M6 x P1.0	D1 24 D2 8 D3 27 D4 M8 x P1.25	D1 32 D2 10 D3 35 D4 M10 x P1.5	D1 40 D2 12 D3 43 D4 M10 x P1.5	D1 48 D2 12 D3 51 D4 M12 x P1.75	D1 55 D2 14 D3 58.5 D4 M16 x P2.0	D1 60 D2 14 D3 63.5 D4 M20 x P2.5	D1 70 D2 16 D3 74 D4 M20 x P2.5
Weight	重量 3.2	5.0	9.1	14.0	21.0	30.6	42.8	67.9

HY-RS series

RATIO : 25.50.75.100.150 (雙段 2-Stage)

搭配行星減速機 - 單出力軸心

Fitted with Planetary Reducer - Single Output Shaft

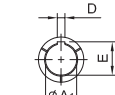
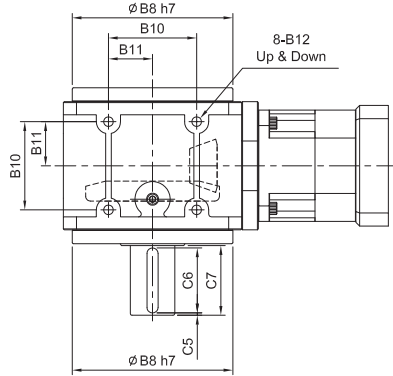
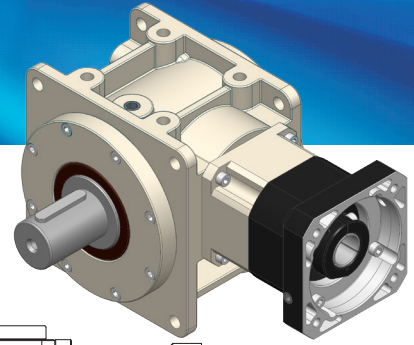

(入力 ϕ 38(φ)以上)

$\phi A1$	D	E
$\phi 38$	10	41.3
$\phi 42$	12	45.3
$\phi 48$	14	51.8
$\phi 55$	16	59.3

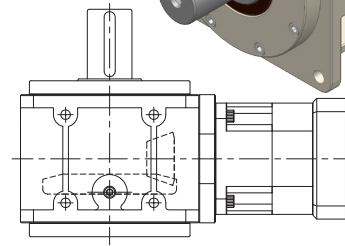

R 軸
Shaft Direction

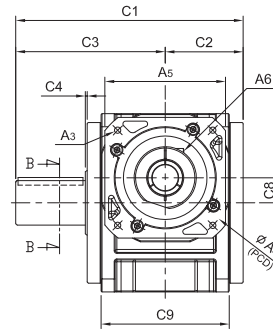
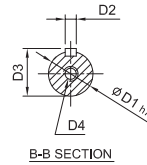
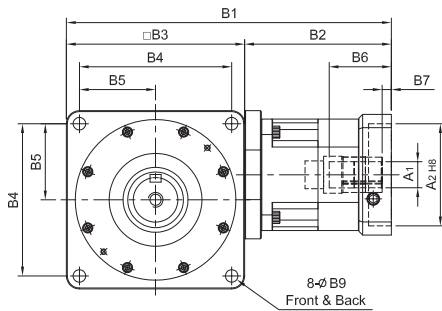

unit: mm

Model Code	55	75	90	115	130	140	160	190	
A	A1	8 · 11	14	(14) · 19	19 · 24	28 · 32	32 · 35	32 · 35	38 · 42 · 48 · 55
	A2	30 · 40 · 50	50 · 60 · 70	50 · 70 · 80 · 95	70 · 80 · 95 · 110	95 · 110 · 130	110 · 130 · 180	110 · 130 · 180	114.3 · 180 · 230 · 250
	A3	M3 · M4 · M5	M4 · M5 · M6	M5 · M6	M5 · M6 · M8	M6 · M8 · M10	M8 · M10 · M12	M8 · M10 · M12	M12 · M16
	A4	46 · 60 · 63	70 · 75 · 90	70 · 90 · 100 · 115	90 · 100 · 115 · 145	115 · 145 · 165	145 · 165 · 200	145 · 165 · 200	200 · 215 · 265 · 300
	A5	46 · 55	64 · 70 · 80	80 · 92 · 110	92 · 110 · 130	122 · 130 · 150	146 · 150 · 190	146 · 150 · 190	182 · 200 · 250 · 265
	A6	M3 x P.05	M5 x P0.8	M5 x P0.8	M6 x P1.0	M8 x P1.25	M10 x P1.5	M10 x P1.5	M10 x P1.5
B	B1	157	201	(224.5) · 237	287	340	405	430	508 · 510
	B2	67	86	(84.5) · 97	117	148	190	190	244 · 246
	B3	90	115	140	170	192	215	240	264
	B4	78	98	118	144	164	182	206	224
	B5	39	49	59	72	82	91	103	112
	B6	26	32	(33.5) · 45.5	59	67	84.5	84.5	114.5 · 116.5
	B7	5	6	(6) · 10	9	10	10	10	11.5 · 13.5
	B8	84	103	128	148	173	200	227	254
	B9	6.8	9	11	11	13.5	15	17.5	17.5
	B10	44	54	66	80	95	104	120	140
	B11	22	27	33	40	47.5	52	60	70
	B12	M6 x P1.0	M8 x P1.25	M10 x P1.5	M12 x P1.75	M12 x P1.75	M14 x P2.0	M16 x P2.0	M16 x P2.0
C	C1	121	146	180	214	245	275	310	350
	C2	42	52	64	76	84	91.5	103	118
	C3	79	94	120	138	161	183.5	206	231
	C4	2	2	2	2	2	2	2	2
	C5	5	5	5	5	5	5	5	5
	C6	25	30	40	50	65	80	90	100
	C7	35	40	50	60	75	90	100	110
	C8	9	14	18	23	27	32	38	42
	C9	60	80	100	120	138	146	166	196
D	D1	20	24	32	40	48	55	60	70
	D2	6	8	10	12	12	14	14	16
	D3	22.5	27	35	43	51	58.5	63.5	74
	D4	M6 x P1.0	M8 x P1.25	M10 x P1.5	M10 x P1.5	M12 x P1.75	M16 x P2.0	M20 x P2.5	M20 x P2.5
Weight	重量	3.8	6.3	10.9	17.7	29.6	45.2	57.4	94.6

HY-DS series

RATIO : 5.10.15 (單段 1-Stage)

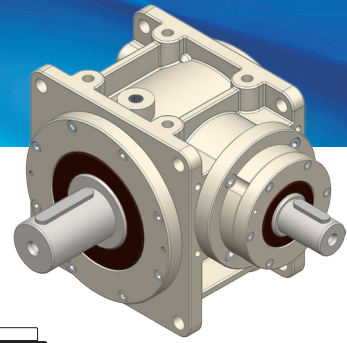

單入力軸心 - 單出力軸心

Single Input Shaft - Single Output Shaft

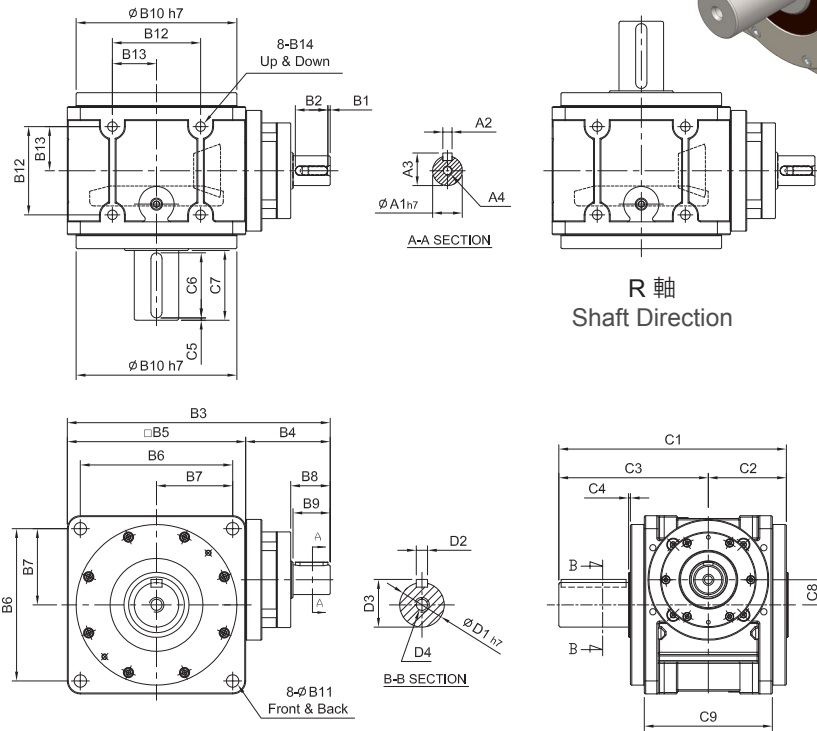

R 軸
Shaft Direction

unit: mm

Model Code	55	75	90	115	130	140	160	190	
	A	A1	14	19	24	28	32	32	38
	A2	5	6	8	8	10	10	12	12
	A3	16	21.5	27	31	35	35	41	43
	A4	M5 x P0.8	M6 x P1.0	M8 x P1.25	M10 x P1.5	M10 x P1.5	M10 x P1.5	M12 x P1.75	M12 x P1.75
B	B1	2.5	2.5	2.5	2.5	5	5	5	5
	B2	20	25	35	35	40	40	50	50
	B3	147	180.5	218	260	293	315	367	402.5
	B4	57	65.5	78	90	101	100	127	138.5
	B5	90	115	140	170	192	215	240	264
	B6	78	98	118	144	164	182	206	224
	B7	39	49	59	72	82	91	103	112
	B8	27	32	42.5	42.5	52.5	51.5	63	63.5
	B9	25	30	40	40	50	50	60	60
	B10	84	103	128	148	173	200	227	254
	B11	6.8	9	11	11	13.5	15	17.5	17.5
	B12	44	54	66	80	95	104	120	140
	B13	22	27	33	40	47.5	52	60	70
	B14	M6 x P1.0	M8 x P1.25	M10 x P1.5	M12 x P1.75	M12 x P1.75	M14 x P2.0	M16 x P2.0	M16 x P2.0
C	C1	121	146	180	214	245	275	310	350
	C2	42	52	64	76	84	91.5	103	118
	C3	79	94	120	138	161	183.5	206	231
	C4	2	2	2	2	2	2	2	2
	C5	5	5	5	5	5	5	5	5
	C6	25	30	40	50	65	80	90	100
	C7	35	40	50	60	75	90	100	110
	C8	9	14	18	23	27	32	38	42
	C9	60	80	100	120	138	146	166	196
D	D1	20	24	32	40	48	55	60	70
	D2	6	8	10	12	12	14	14	16
	D3	22.5	27	35	43	51	58.5	63.5	74
	D4	M6 x P1.0	M8 x P1.25	M10 x P1.5	M10 x P1.5	M12 x P1.75	M16 x P2.0	M20 x P2.5	M20 x P2.5
Weight	重量	2.9	5.0	8.7	12.0	21.1	32.8	42.0	64.6

HY-FV series

RATIO : 5.10.15 (單段 1-Stage)

入力法蘭 - 雙出力軸心

Input Flange - Double Output Shaft

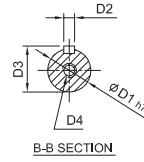
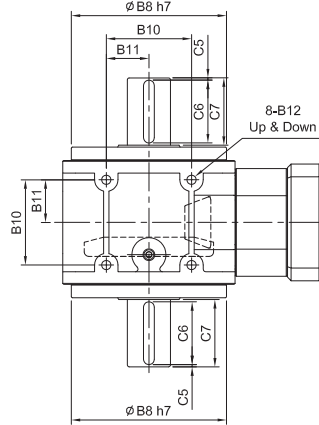
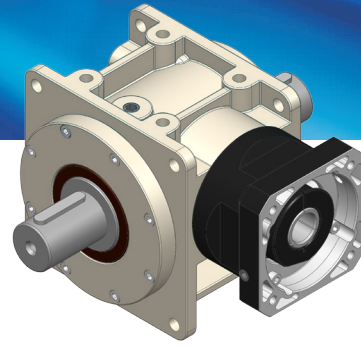

$\phi A1$	D	E
$\phi 35$	10	38.3
$\phi 38$	10	41.3
$\phi 42$	12	45.3
$\phi 48$	14	51.8

(入力径 $\phi 35$ (含)以上)

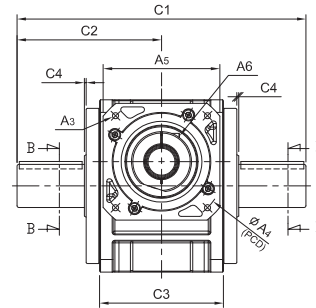
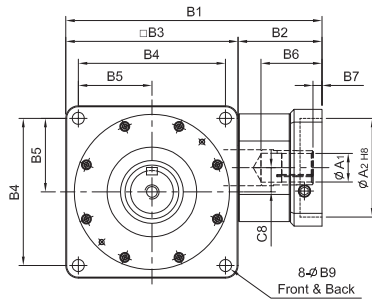

unit: mm

Model Code	55	75	90	115	130	140	160	190	
A	A1	8 · 11	14	14 · 19	19 · 24	28 · 32	35	35 · 38	42 · 48
	A2	30 · 40 · 50	50 · 60 · 70	50 · 70 · 80 · 95	70 · 80 · 95 · 110	95 · 110 · 130	110 · 130 · 180	110 · 130 · 180	114.3 · 180 · 230 · 250
	A3	M3 · M4 · M5	M4 · M5 · M6	M5 · M6	M5 · M6 · M8	M6 · M8 · M10	M8 · M10 · M12	M8 · M10 · M12	M12 · M16
	A4	46 · 60 · 63	70 · 75 · 90	70 · 90 · 100 · 115	90 · 100 · 115 · 145	115 · 145 · 165	145 · 165 · 200	145 · 165 · 200	200 · 215 · 265 · 300
	A5	46 · 55	64 · 70 · 80	80 · 92 · 110	92 · 110 · 130	122 · 130 · 150	146 · 150 · 190	146 · 150 · 190	182 · 200 · 250 · 265
	A6	M3 x P.05	M5 x P0.8	M5 x P0.8	M6 x P1.0	M8 x P1.25	M10 x P1.5	M10 x P1.5	M10 x P1.5
B	B1	123	158	202	241	286	333	358	417 · 419
	B2	33	43	62	71	94	118	118	153 · 155
	B3	90	115	140	170	192	215	240	264
	B4	78	98	118	144	164	182	206	224
	B5	39	49	59	72	82	91	103	112
	B6	26	38	49	58	69.5	81.5	81.5	114.5 · 116.5
	B7	5	6	9	8	10	10	10	11.5 · 13.5
	B8	84	103	128	148	173	200	227	254
	B9	6.8	9	11	11	13.5	15	17.5	17.5
	B10	44	54	66	80	95	104	120	140
	B11	22	27	33	40	47.5	52	60	70
B12	M6 x P1.0	M8 x P1.25	M10 x P1.5	M12 x P1.75	M12 x P1.75	M14 x P2.0	M16 x P2.0	M16 x P2.0	
C	C1	158	188	232	276	322	367	412	462
	C2	79	94	116	138	161	183.5	206	231
	C3	60	80	100	120	138	146	166	196
	C4	2	2	2	2	2	2	2	2
	C5	5	5	5	5	5	5	5	5
	C6	25	30	40	50	65	80	90	100
	C7	35	40	50	60	75	90	100	110
	C8	9	14	18	23	27	32	38	42
D	D1	20	24	32	40	48	55	60	70
	D2	6	8	10	12	12	14	14	16
	D3	22.5	27	35	43	51	58.5	63.5	74
	D4	M6 x P1.0	M8 x P1.25	M10 x P1.5	M10 x P1.5	M12 x P1.75	M16 x P2.0	M20 x P2.5	M20 x P2.5
Weight	重量	3.4	5.4	9.7	15.3	23.1	34.7	47.1	74.0

HY-RV series

RATIO : 25.50.75.100.150 (雙段 2-Stage)

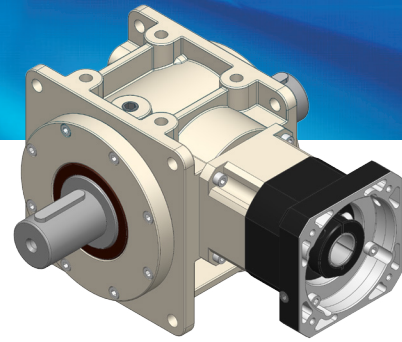

搭配行星減速機 - 雙出力軸心

Fitted with Planetary Reducer - Double Output Shaft

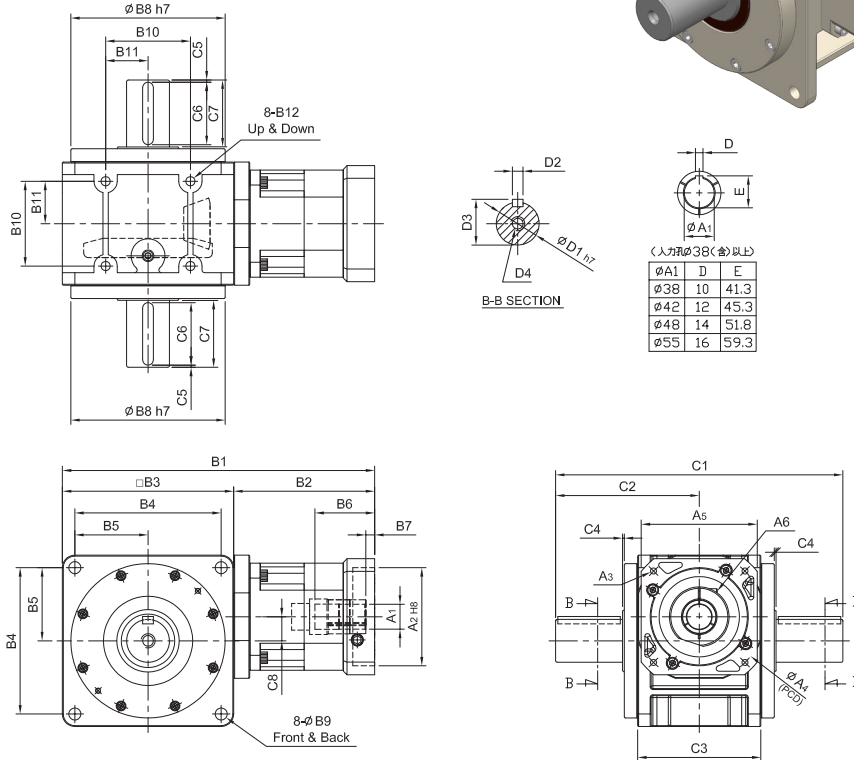

unit: mm

Model Code	55	75	90	115	130	140	160	190
	A	A1: 8·11 A2: 30·40·50 A3: M3·M4·M5 A4: 46·60·63 A5: 46·55 A6: M3 x P.05	A1: 14 A2: 50·60·70 A3: M4·M5·M6 A4: 70·75·90 A5: 64·70·80 A6: M5 x P0.8	A1: (14)·19 A2: 50·70·80·95 A3: M5·M6 A4: 70·90·100·115 A5: 80·92·110 A6: M5 x P0.8	A1: 19·24 A2: 70·80·95·110 A3: M5·M6·M8 A4: 90·100·115·145 A5: 92·110·130 A6: M6 x P1.0	A1: 28·32 A2: 95·110·130 A3: M6·M8·M10 A4: 115·145·165 A5: 122·130·150 A6: M8 x P1.25	A1: 32·35 A2: 110·130·180 A3: M8·M10·M12 A4: 145·165·200 A5: 146·150·190 A6: M10 x P1.5	A1: 32·35 A2: 110·130·180 A3: M8·M10·M12 A4: 145·165·200 A5: 146·150·190 A6: M10 x P1.5
B	B1: 157 B2: 67 B3: 90 B4: 78 B5: 39 B6: 26 B7: 5 B8: 84 B9: 6.8 B10: 44 B11: 22 B12: M6 x P1.0	B1: 201 B2: 86 B3: 115 B4: 98 B5: 49 B6: 32 B7: 6 B8: 103 B9: 9 B10: 54 B11: 27 B12: M8 x P1.25	B1: (224.5)·237 B2: (84.5)·97 B3: 140 B4: 118 B5: 59 B6: (33.5)·45.5 B7: (6)·10 B8: 128 B9: 11 B10: 66 B11: 33 B12: M10 x P1.5	B1: 287 B2: 117 B3: 170 B4: 144 B5: 72 B6: 59 B7: 9 B8: 148 B9: 11 B10: 80 B11: 40 B12: M12 x P1.75	B1: 340 B2: 148 B3: 192 B4: 164 B5: 82 B6: 67 B7: 10 B8: 173 B9: 13.5 B10: 95 B11: 47.5 B12: M12 x P1.75	B1: 405 B2: 190 B3: 215 B4: 182 B5: 91 B6: 84.5 B7: 10 B8: 200 B9: 15 B10: 104 B11: 52 B12: M14 x P2.0	B1: 430 B2: 190 B3: 240 B4: 206 B5: 103 B6: 84.5 B7: 10 B8: 227 B9: 17.5 B10: 120 B11: 60 B12: M16 x P2.0	B1: 508·510 B2: 244·246 B3: 264 B4: 224 B5: 112 B6: 114.5·116.5 B7: 11.5·13.5 B8: 254 B9: 17.5 B10: 140 B11: 70 B12: M16 x P2.0
C	C1: 158 C2: 79 C3: 60 C4: 2 C5: 5 C6: 25 C7: 35 C8: 9	C1: 188 C2: 94 C3: 80 C4: 2 C5: 5 C6: 30 C7: 40 C8: 14	C1: 232 C2: 116 C3: 100 C4: 2 C5: 5 C6: 40 C7: 50 C8: 18	C1: 276 C2: 138 C3: 120 C4: 2 C5: 5 C6: 50 C7: 60 C8: 23	C1: 322 C2: 161 C3: 138 C4: 2 C5: 5 C6: 65 C7: 75 C8: 27	C1: 367 C2: 183.5 C3: 146 C4: 2 C5: 5 C6: 80 C7: 90 C8: 32	C1: 412 C2: 206 C3: 166 C4: 2 C5: 5 C6: 90 C7: 100 C8: 38	C1: 462 C2: 231 C3: 196 C4: 2 C5: 5 C6: 100 C7: 110 C8: 42
D	D1: 20 D2: 6 D3: 22.5 D4: M6 x P1.0	D1: 24 D2: 8 D3: 27 D4: M8 x P1.25	D1: 32 D2: 10 D3: 35 D4: M10 x P1.5	D1: 40 D2: 12 D3: 43 D4: M10 x P1.5	D1: 48 D2: 12 D3: 51 D4: M12 x P1.75	D1: 55 D2: 14 D3: 58.5 D4: M16 x P2.0	D1: 60 D2: 14 D3: 63.5 D4: M20 x P2.5	D1: 70 D2: 16 D3: 74 D4: M20 x P2.5
Weight	重量: 4.0	6.6	11.5	18.9	31.7	41.2	61.6	100.6

HY-DV series

RATIO : 5.10.15 (單段 1-Stage)

單入力軸心 - 雙出力軸心

Single Input Shaft - Double Output Shaft

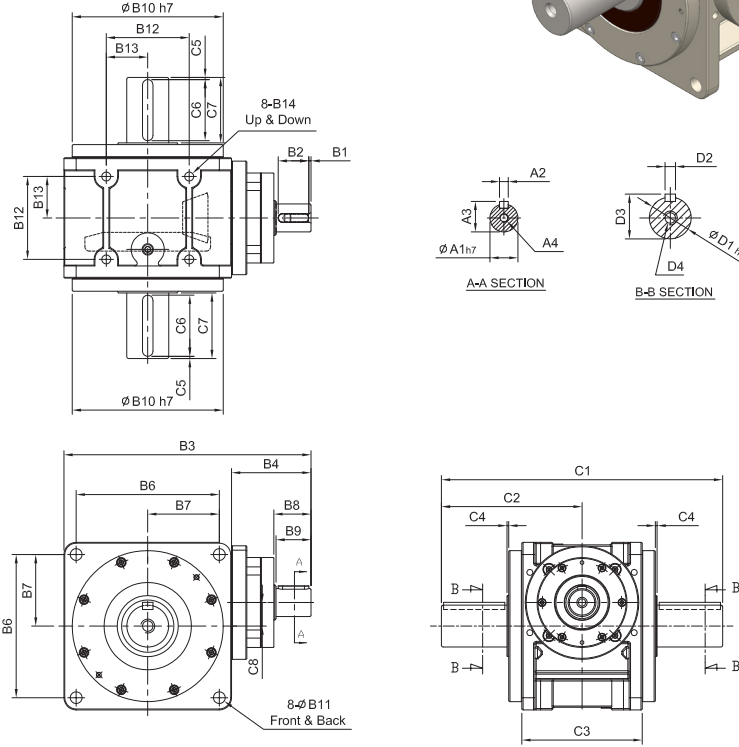
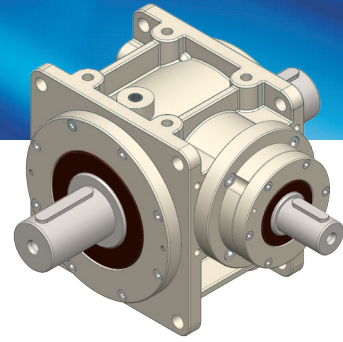

unit: mm

Model Code	55	75	90	115	130	140	160	190	
A	A1	14	19	24	28	32	38	40	
	A2	5	6	8	8	10	12	12	
	A3	16	21.5	27	31	35	41	43	
	A4	M5 x P0.8	M6 x P1.0	M8 x P1.25	M10 x P1.5	M10 x P1.5	M10 x P1.5	M12 x P1.75	M12 x P1.75
B	B1	2.5	2.5	2.5	2.5	5	5	5	
	B2	20	25	35	35	40	40	50	
	B3	147	181	218	260	293	315	367	
	B4	57	66	78	90	101	100	127	
	B5	90	115	140	170	192	215	240	
	B6	78	98	118	144	164	182	206	
	B7	39	49	59	72	82	91	103	
	B8	27	32	42.5	42.5	52.5	51.5	63	
	B9	25	30	40	40	50	50	60	
	B10	84	103	128	148	173	200	227	
	B11	6.8	9	11	11	13.5	15	17.5	
	B12	44	54	66	80	95	104	120	
	B13	22	27	33	40	47.5	52	60	
	B14	M6 x P1.0	M8 x P1.25	M10 x P1.5	M12 x P1.75	M12 x P1.75	M14 x P2.0	M16 x P2.0	M16 x P2.0
C	C1	158	188	232	276	322	412	462	
	C2	79	94	116	138	161	183.5	206	
	C3	60	80	100	120	138	146	166	
	C4	2	2	2	2	2	2	2	
	C5	5	5	5	5	5	5	5	
	C6	25	30	40	50	65	80	90	
	C7	35	40	50	60	75	90	100	
	C8	9	14	18	23	27	32	38	
D	D1	20	24	32	40	48	55	60	
	D2	6	8	10	12	12	14	14	
	D3	22.5	27	35	43	51	58.5	63.5	
	D4	M6 x P1.0	M8 x P1.25	M10 x P1.5	M10 x P1.5	M12 x P1.75	M16 x P2.0	M20 x P2.5	M20 x P2.5
Weight	重量	3.1	5.3	9.2	14.7	23.6	37.7	47.8	70.6

HY-FP series

RATIO : 5.10.15 (單段 1-Stage)

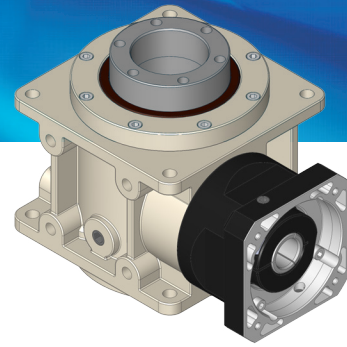

入力法蘭 - 螺桿式

Input Flange - Ball Screw

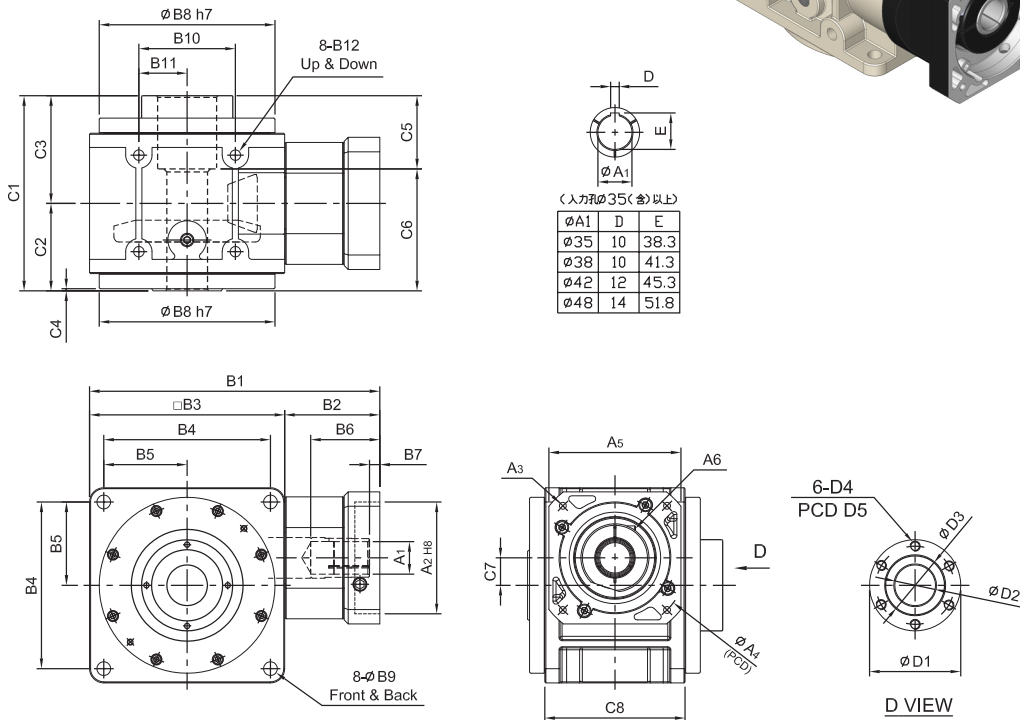

unit: mm

Model Code	75	90	115	130	140	160	190
	A	A1: 14 A2: 50·60·70 A3: M4·M5·M6 A4: 70·75·90 A5: 64·70·80 A6: M5 x P0.8	A1: 14·19 A2: 50·70·80·95 A3: M5·M6 A4: 70·90·100·115 A5: 80·92·110 A6: M5 x P0.8	A1: 19·24 A2: 70·80·95·110 A3: M5·M6·M8 A4: 90·100·115·145 A5: 92·110·130 A6: M6 x P1.0	A1: 28·32 A2: 95·110·130 A3: M6·M8·M10 A4: 115·145·165 A5: 122·130·150 A6: M8 x P1.25	A1: 35 A2: 110·130·180 A3: M8·M10·M12 A4: 145·165·200 A5: 146·150·190 A6: M10 x P1.5	A1: 35·38 A2: 110·130·180 A3: M8·M10·M12 A4: 145·165·200 A5: 146·150·190 A6: M10 x P1.5
B	B1: 158 B2: 43 B3: 115 B4: 98 B5: 49 B6: 38 B7: 6 B8: 103 B9: 9 B10: 54 B11: 27 B12: M8 x P1.25	B1: 202 B2: 62 B3: 140 B4: 118 B5: 59 B6: 49 B7: 9 B8: 128 B9: 11 B10: 66 B11: 33 B12: M10 x P1.5	B1: 241 B2: 71 B3: 170 B4: 144 B5: 72 B6: 58 B7: 8 B8: 148 B9: 11 B10: 80 B11: 40 B12: M12 x P1.75	B1: 286 B2: 94 B3: 192 B4: 164 B5: 82 B6: 69.5 B7: 10 B8: 173 B9: 13.5 B10: 95 B11: 47.5 B12: M12 x P1.75	B1: 333 B2: 118 B3: 215 B4: 182 B5: 91 B6: 81.5 B7: 10 B8: 200 B9: 15 B10: 104 B11: 52 B12: M14 x P2.0	B1: 358 B2: 118 B3: 240 B4: 206 B5: 103 B6: 81.5 B7: 10 B8: 227 B9: 17.5 B10: 120 B11: 60 B12: M16 x P2.0	B1: 417·419 B2: 153·155 B3: 264 B4: 224 B5: 112 B6: 114.5·116.5 B7: 11.5·13.5 B8: 254 B9: 17.5 B10: 140 B11: 70 B12: M16 x P2.0
C	C1: 125 C2: 58 C3: 67 C4: 3.25 C5: 50 C6: 75 C7: 14 C8: 80	C1: 140 C2: 66 C3: 74 C4: 2 C5: 58 C6: 82 C7: 18 C8: 100	C1: 177 C2: 78.5 C3: 98.5 C4: 2.5 C5: 72 C6: 105 C7: 23 C8: 120	C1: 193 C2: 87 C3: 106 C4: 2 C5: 72 C6: 121 C7: 27 C8: 138	C1: 205 C2: 94 C3: 111 C4: 2.5 C5: 82 C6: 123 C7: 32 C8: 146	C1: 230 C2: 107 C3: 123 C4: 2.5 C5: 92 C6: 138 C7: 38 C8: 166	C1: 260 C2: 123 C3: 137 C4: 3 C5: 117 C6: 143 C7: 42 C8: 196
D	D1: 54.7 D2: 22 D3: 34 D4: M5 x P0.8 D5: 45	D1: 64.7 D2: 30 D3: 40 D4: M5 x P0.8 D5: 51	D1: 89.7 D2: 38 D3: 58 D4: M10 x P1.5 D5: 77	D1: 89.7 D2: 40 D3: 58 D4: M10 x P1.5 D5: 77	D1: 99.7 D2: 44 D3: 64 D4: M10 x P1.5 D5: 84	D1: 117.7 D2: 54 D3: 75 D4: M12 x P1.75 D5: 97	D1: 129.7 D2: 65 D3: 90 D4: M12 x P1.75 D5: 112
Weight	重量: 4.3	重量: 8.3	重量: 12.7	重量: 18.7	重量: 26.9	重量: 37.9	重量: 58.9

HY

HY-RP series

RATIO : 25.50.75.100.150 (雙段 2-Stage)

搭配行星減速機 - 螺桿式

Fitted with Planetary Reducer - Ball Screw

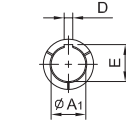
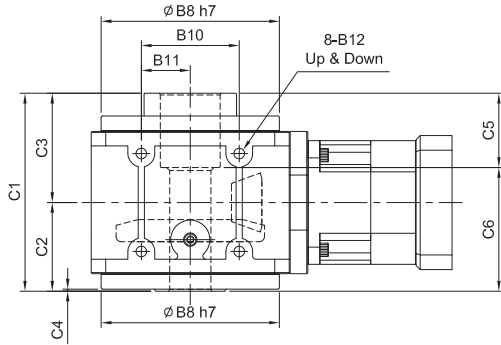
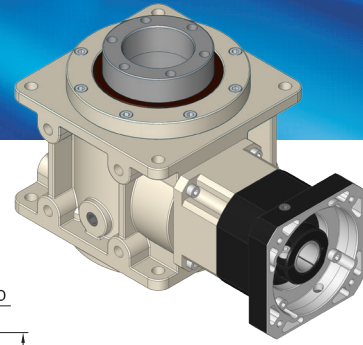

(入力径φ38(含)以上)

φA1	D	E
φ38	10	41.3
φ42	12	45.3
φ48	14	51.8
φ55	16	59.3

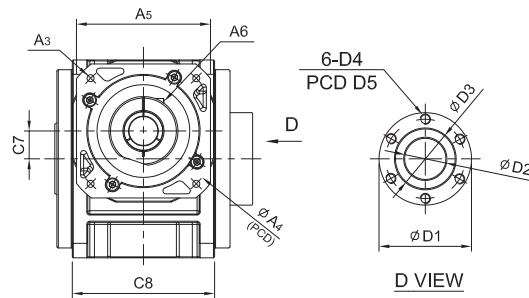
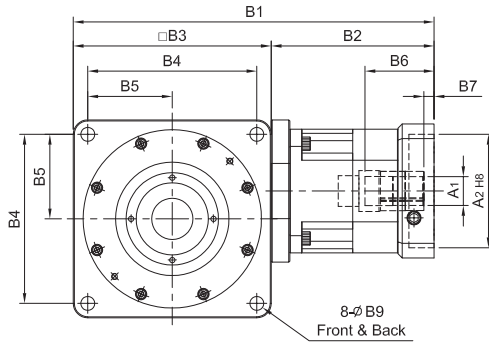

unit: mm

Model Code	75	90	115	130	140	160	190	
A	A1	14	(14) · 19	19 · 24	28 · 32	32 · 35	32 · 35	38 · 42 · 48 · 55
	A2	50 · 60 · 70	50 · 70 · 80 · 95	70 · 80 · 95 · 110	95 · 110 · 130	110 · 130 · 180	110 · 130 · 180	114.3 · 180 · 230 · 250
	A3	M4 · M5 · M6	M5 · M6	M5 · M6 · M8	M6 · M8 · M10	M8 · M10 · M12	M8 · M10 · M12	M12 · M16
	A4	70 · 75 · 90	70 · 90 · 100 · 115	90 · 100 · 115 · 145	115 · 145 · 165	145 · 165 · 200	145 · 165 · 200	200 · 215 · 265 · 300
	A5	64 · 70 · 80	80 · 92 · 110	92 · 110 · 130	122 · 130 · 150	146 · 150 · 190	146 · 150 · 190	182 · 200 · 250 · 265
	A6	M5 x P0.8	M5 x P0.8	M6 x P1.0	M8 x P1.25	M10 x P1.5	M10 x P1.5	M10 x P1.5
B	B1	201	(224.5) · 237	287	340	405	430	508 · 510
	B2	86	(84.5) · 97	117	148	190	190	244 · 246
	B3	115	140	170	192	215	240	264
	B4	98	118	144	164	182	206	224
	B5	49	59	72	82	91	103	112
	B6	32	(33.5) · 45.5	59	67	84.5	84.5	114.5 · 116.5
	B7	6	(6) · 10	9	10	10	10	11.5 · 13.5
	B8	103	128	148	173	200	227	254
	B9	9	11	11	13.5	15	17.5	17.5
	B10	54	66	80	95	104	120	140
	B11	27	33	40	47.5	52	60	70
	B12	M8 x P1.25	M10 x P1.5	M12 x P1.75	M12 x P1.75	M14 x P2.0	M16 x P2.0	M16 x P2.0
C	C1	125	140	177	193	205	230	260
	C2	58	66	78.5	87	94	107	123
	C3	67	74	98.5	106	111	123	137
	C4	3.25	2	2.5	2	2.5	2.5	3
	C5	50	58	72	72	82	92	117
	C6	75	82	105	121	123	138	143
	C7	14	18	23	27	32	38	42
	C8	80	100	120	138	146	166	196
D	D1	54.7	64.7	89.7	89.7	99.7	117.7	129.7
	D2	22	30	38	40	44	54	65
	D3	34	40	58	58	64	75	90
	D4	M5 x P0.8	M5 x P0.8	M10 x P1.5	M10 x P1.5	M10 x P1.5	M12 x P1.75	M12 x P1.75
	D5	45	51	77	77	84	97	112
Weight	重量	5.5	10.1	16.4	27.3	41.5	52.5	85.5

HY-DP series

RATIO : 5.10.15 (單段 1-Stage)

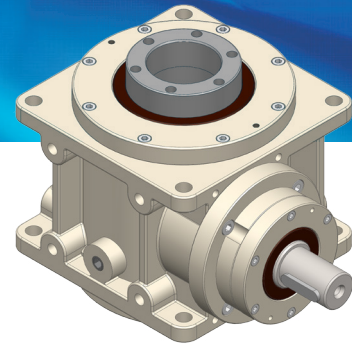

單入力軸心 - 螺桿式

Single Input Shaft - Ball Screw

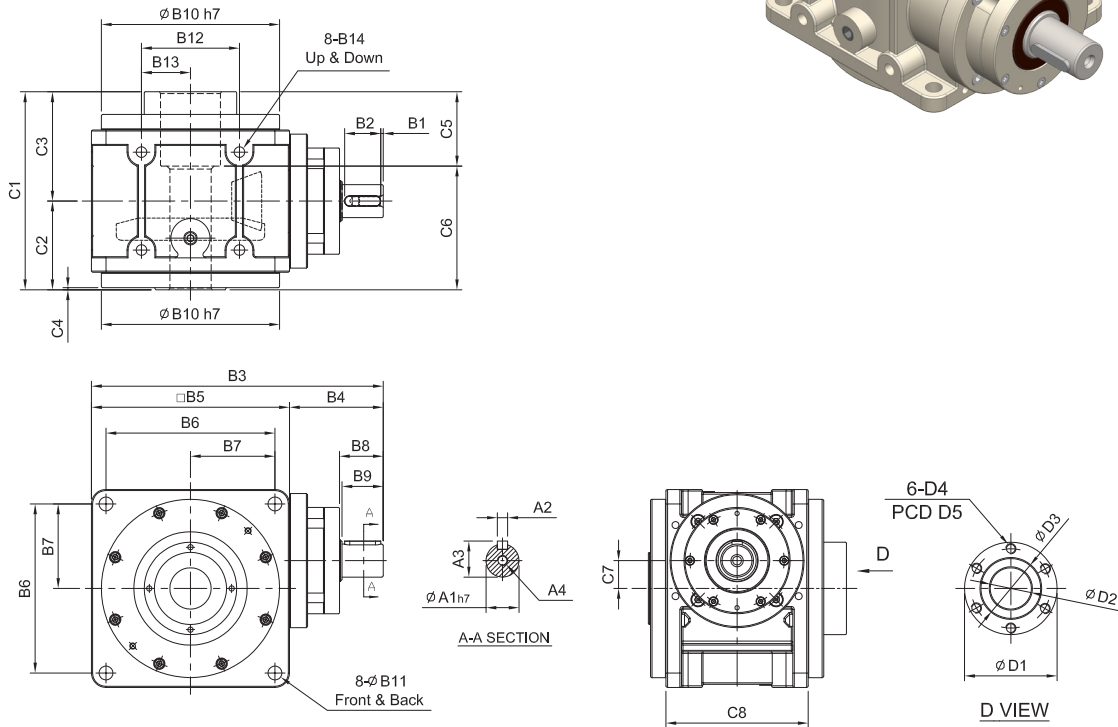

unit: mm

Model Code	75	90	115	130	140	160	190	
	A							
A1	19	24	28	32	32	38	40	
A2	6	8	8	10	10	12	12	
A3	21.5	27	31	35	35	41	43	
A4	M6 x P1.0	M8 x P1.25	M10 x P1.5	M10 x P1.5	M10 x P1.5	M12 x P1.75	M12 x P1.75	
B								
B1	2.5	2.5	2.5	5	5	5	5	
B2	25	35	35	40	40	50	50	
B3	181	218	260	293	315	367	403	
B4	66	78	90	101	100	127	139	
B5	115	140	170	192	215	240	264	
B6	98	118	144	164	182	206	224	
B7	49	59	72	82	91	103	112	
B8	32	42.5	42.5	52.5	51.5	63	63.5	
B9	30	40	40	50	50	60	60	
B10	103	128	148	173	200	227	254	
B11	9	11	11	13.5	15	17.5	17.5	
B12	54	66	80	95	104	120	140	
B13	27	33	40	47.5	52	60	70	
B14	M8 x P1.25	M10 x P1.5	M12 x P1.75	M12 x P1.75	M14 x P2.0	M16 x P2.0	M16 x P2.0	
C								
C1	125	140	177	193	205	230	260	
C2	58	66	78.5	87	94	107	123	
C3	67	74	98.5	106	111	123	137	
C4	3.25	2	2.5	2	2.5	2.5	3	
C5	50	58	72	72	82	92	117	
C6	75	82	105	121	123	138	143	
C7	14	18	23	27	32	38	42	
C8	80	100	120	138	146	166	196	
D								
D1	54.7	64.7	89.7	89.7	99.7	117.7	129.7	
D2	22	30	38	40	44	54	65	
D3	34	40	58	58	64	75	90	
D4	M5 x P0.8	M5 x P0.8	M10 x P1.5	M10 x P1.5	M10 x P1.5	M12 x P1.75	M12 x P1.75	
D5	45	51	77	77	84	97	112	
Weight	重量							
		4.2	7.8	12.2	19.2	29.6	38.7	55.5

Reference Information of Ball Screw

滾珠螺桿參考資料

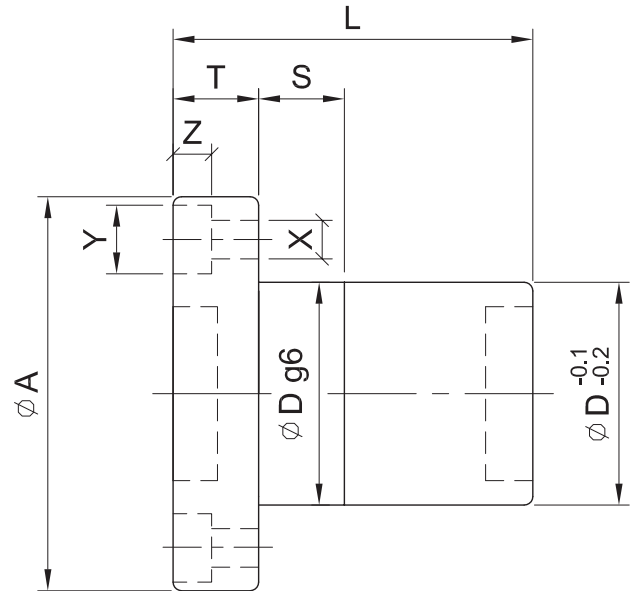
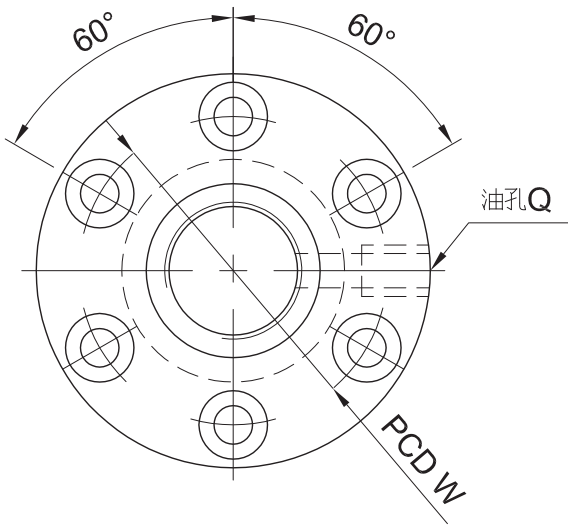
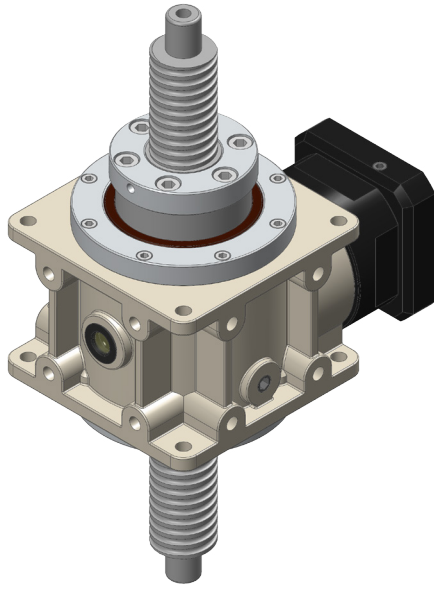

配合 減速機 型號 Model of Reducer	螺桿尺寸 Screw Size		基本額定負荷 Basic Rate Load (kgf)		螺帽 Nut		法蘭 Flange			配合 FIT	螺絲孔 Screw Bolt			油孔 Oil Hole	螺桿 長度 Length
	外徑 O.D.	導程 Lead	動負荷 Dynamic	靜負荷 Static	Dg6	L	A	T	W		S	X	Y		
55	-	-	-	-	-	-	-	-	-	-	-	-	-	-	-
75	20	6	1,380	2,730	34	61	57	12	45	12	5.5	9.5	5.5	M6 x P1	≤ 1500
90	25	8	1,630	3,650	40	69	63.5	12	51	15	5.5	9.5	5.5	M8 x P1	≤ 1500
115	36	10	3,600	8,280	58	89	98	18	77	20	11	17.5	11	M8 x P1	≤ 1500
130	36	10	3,600	8,280	58	89	98	18	77	20	11	17.5	11	M8 x P1	≤ 1500
140	40	10	4,670	11,830	64	99	106	18	84	20	11	17.5	11	M8 x P1	≤ 1500
160	50	12	5,770	14,870	75	111	121	22	97	20	14	20	13	1/8"PT	≤ 1500
190	63	12	9,320	29,150	90	136	136	22	112	20	14	20	13	1/8"PT	≤ 1500

Flange (B)

旋盤 (B)

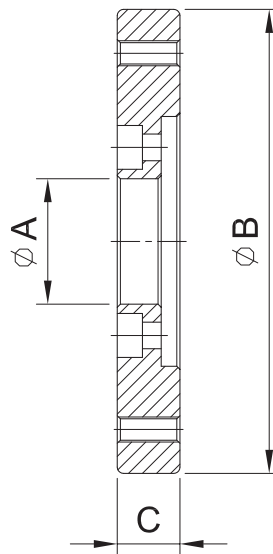
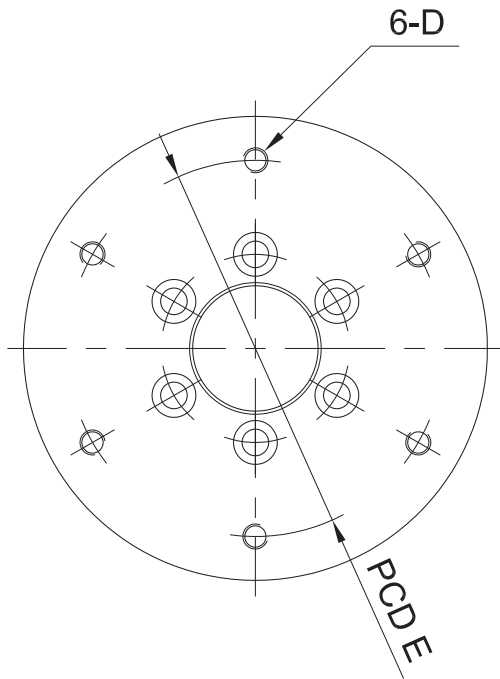
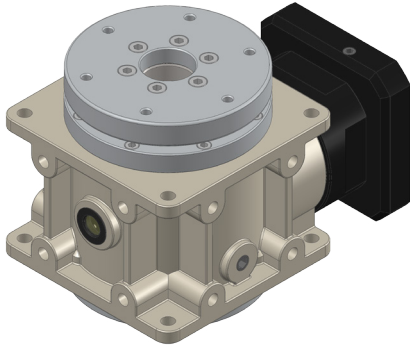

Model / Code	55	75	90	115	130	140	160	190
A	-	25	30	40	45	50	55	60
B	-	102	128	148	168	198	228	248
C	-	15	16	20	23	24	23	27
D	-	M6 x P1.0	M8 x P1.25	M8 x P1.25	M10 x P1.5	M10 x P1.5	M10 x P1.5	M12 x P1.25
E	-	80	100	120	140	160	180	200

HK series

HK

Indication of Model Numbers

機種型號表示

HK	64		B	5	P0	
減速機機型 Type	型號 Model	出力表示 Output	軸承形式 Bearing	速比 Ratio	背隙等級 Backlash Class	馬達型號 Motor Type
HK	64 90 110 140 200		B : 滾珠軸承 Ball Bearing (64#~140#) T : 滾錐軸承 Taper Bearing (200#)	5 10 15	P0 ≤ 3 P1 ≤ 6 P2 ≤ 9	

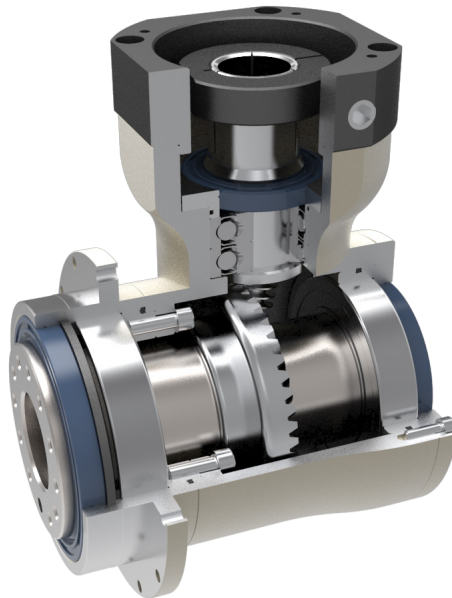

Characteristic of HK Series

HK 系列產品特性

單段減速機 1-Stage

規格 Model No.	代號	單位 Unit	速比 Ratio	64	90	110	140	200
額定輸出扭矩 / Rated Output Torque (Nominal output torque)	T_{2N}	Nm	5	30	70	140	260	720
			10	25	60	117	220	615
			15	20	50	95	180	510
最大加速扭矩 / Max. Acceleration Torque	T_{2B}	Nm	5~15	1.5 倍額定輸出扭矩 1.5 Times of Rated Output Torque				
最大輸出扭矩 / Max. Output Torque 急停扭矩 / Emergency Stop Torque	T_{2NOT}	Nm	5~15	3 倍額定輸出扭矩 3 Times of Rated Output Torque				
額定輸入轉速 / Rated Input Speed	n_{1N}	rpm	5	2,200	1,800	1,500	1,150	700
			10	3,300	2,700	2,200	1,800	1,200
			15	4,000	3,300	2,800	2,300	1,600
最大輸入轉速 / Max. Input Speed	n_{1B}	rpm	5~15	6,000	5,000	4,000	3,000	3,000
背隙 / Backlash	J_t	arcmin	P0	≤ 3	≤ 3	≤ 3	≤ 3	≤ 3
			P1	≤ 6	≤ 6	≤ 6	≤ 6	≤ 6
			P2	≤ 9	≤ 9	≤ 9	≤ 9	≤ 9
容許徑向力 / Max. Radial Force 滾珠軸承 Ball Bearing	F_{2rB}	N	5~15	1,040	2,366	3,900	5,837	-
容許軸向力 / Max. Axial Force 滾珠軸承 Ball Bearing	F_{2aB}	N	5~15	520	1183	1950	2919	-
容許徑向力 / Max. Radial Force 滾錐軸承 Taper Bearing	F_{2rB}	N	5~15	-	-	-	-	14,420
容許軸向力 / Max. Axial Force 滾錐軸承 Taper Bearing	F_{2aB}	N	5~15	-	-	-	-	7,210
使用壽命 / Service Life	L_{H1}	hr	5~15	S5 周期運轉 : >30,000 (S1 連續運轉 : >15,000 hrs) S5 Cycle Operation: >30,000 (S1 Continuous Operation: >15,000 hrs)				
效 率 / Efficiency	η	%	5	≥ 96%				
			10~15	≥ 93%				
使用溫度 / Operating Temperature		°C	5~15	-10°C ~ +90°C				
潤 滑 / Lubrication			5~15	全合成潤滑油 Synthetic Oil				
噪 音 值 / Noise Level		dB	5~15	≤ 66	≤ 67	≤ 68	≤ 69	≤ 70

轉動慣量 Mass Moments of Inertia (kgcm²)

速比 Ratio	64	90	110	140	200
5	0.23	0.58	1.41	4.00	13.53
10	0.15	0.38	1.00	2.46	7.38
15	0.13	0.34	0.81	2.07	5.76

HK series

RATIO : 5.10.15 (單段 1-Stage)

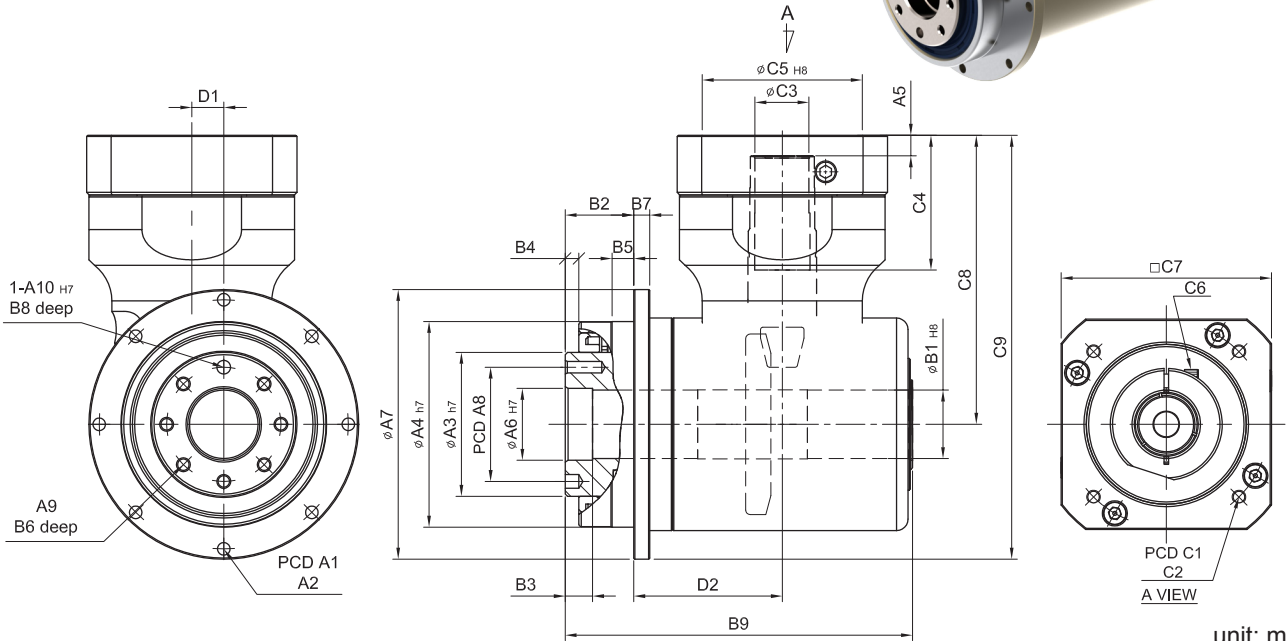

unit: mm

Model Code	64	90	110	140	200	
A	A1	79	109	135	168	233
	A2	8-4.5	8-5.5	8-5.5	12-6.6	12-9.0
	A3 h7	40	63	80	100	160
	A4 h7	64	90	110	140	200
	A5	5	6	9	10	10
	A6 H7	20	31.5	40	50	80
	A7	86	118	146	179	248
	A8	31.5	50	63	80	125
	A9	7-M5 x P0.8	7-M6 x P1.0	11-M6 x P1.0	11-M8 x P1.25	11-M10 x P1.5
	A10 H7	5	6	6	8	10
B	B1 H8	15	30	30	40	55
	B2	19.5	30	29	38	50
	B3	7	12	12	12	16
	B4	4	6	6	6	8
	B5	6	10	10	15	15
	B6	10	12	12	16	22
	B7	5	7	8	10	12
	B8	6	6	7	7	10
	B9	104.5	152	168	200	260
C	C1	46 · 60 · 63	90 · 110 · 115 · 145	115 · 145 · 165	115 · 145 · 165	145 · 165 · 200
	C2	M3 · M4 · M5	M5 · M6 · M8	M6 · M8 · M10	M6 · M8 · M10	M8 · M10 · M12
	C3	11	24	32	35	42
	C4	26	59	67	82	84.5
	C5 H8	30 · 40 · 50	70 · 80 · 95 · 110	95 · 110 · 130	95 · 110 · 130	110 · 130 · 180
	C6	M3 x P0.5	M6 x P1.0	M8 x P1.25	M8 x P1.25	M10 x P1.5
	C7	46 · 55	92 · 110 · 130	122 · 130 · 150	122 · 130 · 150	146 · 150 · 190
	C8	69	126.5	149	179	228
	C9	112	185.5	222.5	268.5	352.5
	C10	1/8"PT	1/8"PT	1/4"PT	1/4"PT	1/4"PT
D	D1	9	14	18	23	32
	D2	43	65	77	90	117
Weight	重量					

HF series

HF

Indication of Model Numbers

機種型號表示

HF	60	O	B	3	P0	
減速機機型 Type	型號 Model	出力表示 Output	軸承形式 Bearing	速比 Ratio	背隙等級 Backlash Class	馬達型號 Motor Type
HF	60	O: 出力中空軸 Hollow Output Shaft	B : 滾珠軸承 Ball Bearing	5	P0 ≤ 3	
	75	N: 單邊免鍵軸套 (有鍵槽) Single Clamping (Keyway)		10	P1 ≤ 6	
	100	N1: 單邊免鍵軸套 (無鍵槽) Single Clamping (No Keyway)		15	P2 ≤ 9	
	140	M: 雙邊免鍵軸套 Double Clamping				
	180	S: 單出力軸心 (有鍵槽) Single Output Shaft (Keyway)				
		S1: 單出力軸心 (無鍵槽) Single Output Shaft (No Keyway)				

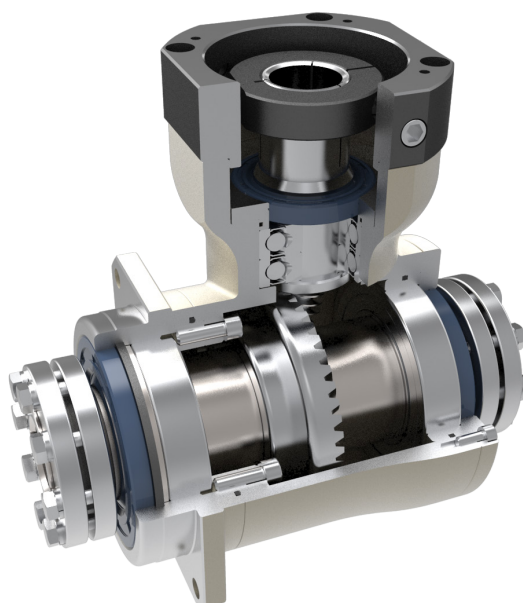

Characteristic of HF Series

HF 系列產品特性

單段減速機 1-Stage

規格 Model No.	代號	單位 Unit	速比 Ratio	60	75	100	140	180
額定輸出扭矩 / Rated Output Torque (Nominal output torque)	T_{2N}	Nm	5	30	35	70	260	720
			10	25	30	60	220	615
			15	20	25	50	180	510
最大加速扭矩 / Max. Acceleration Torque	T_{2B}	Nm	5~15	1.5 倍額定輸出扭矩 1.5 Times of Rated Output Torque				
最大輸出扭矩 / Max. Output Torque 急停扭矩 / Emergency Stop Torque	T_{2NOT}	Nm	5~15	3 倍額定輸出扭矩 3 Times of Rated Output Torque				
額定輸入轉速 / Rated Input Speed	n_{1N}	rpm	5	2,200	2,100	1,800	1,150	700
			10	3,300	3,200	2,700	1,800	1,200
			15	4,000	3,900	3,300	2,300	1,600
最大輸入轉速 / Max. Input Speed	n_{1B}	rpm	5~15	6,000	5,000	4,000	3,000	3,000
背隙 / Backlash	J_t	arcmin	P0	≤ 3	≤ 3	≤ 3	≤ 3	≤ 3
			P1	≤ 6	≤ 6	≤ 6	≤ 6	≤ 6
			P2	≤ 9	≤ 9	≤ 9	≤ 9	≤ 9
容許徑向力 / Max. Radial Force 滾珠軸承 Ball Bearing	F_{2rB}	N	5~15	1,040	1,495	2,366	5,837	7,020
容許軸向力 / Max. Axial Force 滾珠軸承 Ball Bearing	F_{2aB}	N	5~15	520	748	1,183	2,919	3,510
使用壽命 / Service Life	L_H	hr	5~15	S5 周期運轉 : >30,000 (S1 連續運轉 : >15,000 hrs) S5 Cycle Operation: >30,000 (S1 Continuous Operation: >15,000 hrs)				
效 率 / Efficiency	η	%	5~8	≥ 96%				
			10~15	≥ 93%				
使用溫度 / Operating Temperature		°C	5~15	-10°C ~ +90°C				
潤 滑 / Lubrication			5~15	全合成潤滑油 Synthetic Oil				
噪 音 值 / Noise Level		dB	5~15	≤ 66	≤ 66	≤ 66	≤ 68	≤ 70

轉動慣量 Mass Moments of Inertia (kgcm²)

速比 Ratio	60	75	100	140	180
5	0.23	0.23	0.58	4.00	13.53
10	0.15	0.15	0.38	2.46	7.38
15	0.13	0.13	0.34	2.07	5.76

HF-FO series

RATIO : 5.10.15 (單段 1-Stage)

入力法蘭 - 出力中空軸

Input Flange - Hollow Output Shaft

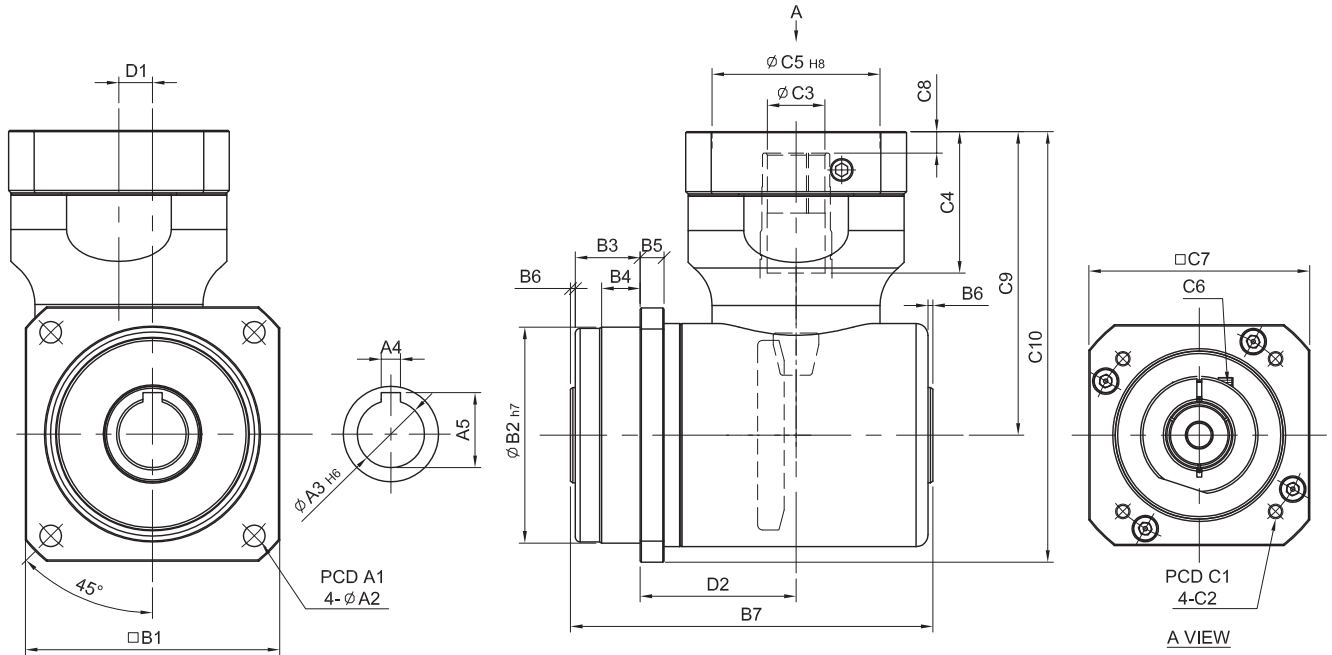
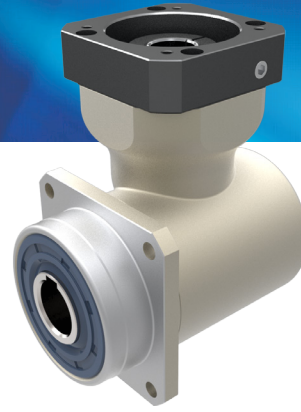

unit: mm

	Model	60	75	100	140	180
	Code					
A	A1	68	85	120	165	215
	A2	5.5	6.5	9	11	13
	A3	15	20	28	40	55
	A4	4	5	8	12	14
	A5	16.7	22.3	31.3	43.3	58.8
B	B1	62	76	106	142	190
	B2	60	70	90	130	160
	B3	18	18	27	27	26
	B4	11	12	16	15.5	15.5
	B5	6	7	10	12	15
	B6	2	2	2	3	3
	B7	103	113	151	193	247
C	C1	46 · 60 · 63	70 · 75 · 90	90 · 100 · 115 · 145	115 · 145 · 165	145 · 165 · 200
	C2	M3 · M4 · M5	M4 · M5 · M6	M5 · M6 · M8	M6 · M8 · M10	M8 · M10 · M12
	C3	11	14	24	35	42
	C4	26	33	59	82	84.5
	C5	30 · 40 · 50	50 · 60 · 70	70 · 80 · 95 · 110	95 · 110 · 130	110 · 130 · 180
	C6	M4 x P0.7	M5 x P0.8	M6 x P1.0	M8 x P1.25	M10 x P1.5
	C7	46 · 55	64 · 70 · 80	92 · 110 · 130	122 · 130 · 150	146 · 150 · 190
	C8	5	6	9	10	10
	C9	69	95.5	126.5	179	228
	C10	100	133.5	179.5	250	323
D	D1	9	9	14	23	32
	D2	41.5	48	65	90	125
Weight	重量					

HF-FN series

RATIO : 5.10.15 (單段 1-Stage)

入力法蘭 - 單邊免鍵軸套
Input Flange - Single Clamping

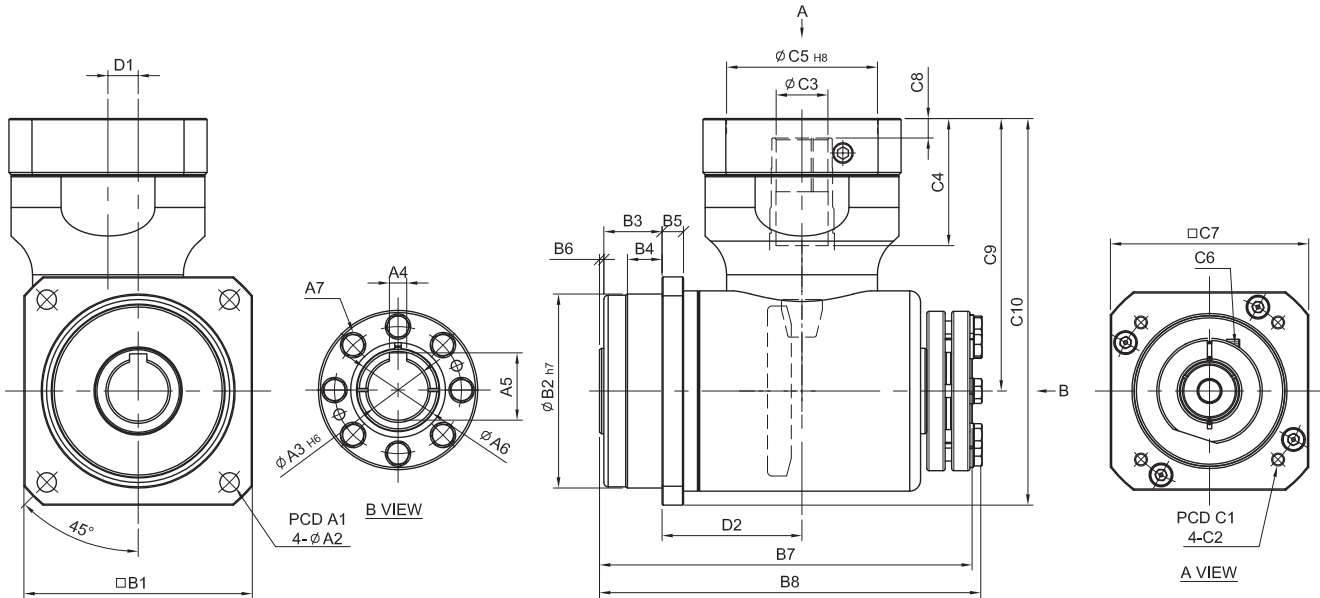

unit: mm

Model Code	60	75	100	140	180	
A	A1	68	85	120	165	215
	A2	5.5	6.5	9	11	13
	A3	15	20	28	40	55
	A4	4	5	8	12	14
	A5	16.7	22.3	31.3	43.3	58.8
	A6	22	28	38	52	73
	A7	6-M6	6-M6	8-M6	8-M6	8-M6
B	B1	62	76	106	142	190
	B2	60	70	90	130	160
	B3	18	18	27	27	26
	B4	11	12	16	15.5	15.5
	B5	6	7	10	12	15
	B6	2	2	2	3	3
	B7	123.5	134	173	223	279
	B8	127.5	138	177	228	283
C	C1	46 · 60 · 63	70 · 75 · 90	90 · 100 · 115 · 145	115 · 145 · 165	145 · 165 · 200
	C2	M3 · M4 · M5	M4 · M5 · M6	M5 · M6 · M8	M6 · M8 · M10	M8 · M10 · M12
	C3	11	14	24	35	42
	C4	26	33	59	82	84.5
	C5	30 · 40 · 50	50 · 60 · 70	70 · 80 · 95 · 110	95 · 110 · 130	110 · 130 · 180
	C6	M4 x P0.7	M5 x P0.8	M6 x P1.0	M8 x P1.25	M10 x P1.5
	C7	46 · 55	64 · 70 · 80	92 · 110 · 130	122 · 130 · 150	146 · 150 · 190
	C8	5	6	9	10	10
	C9	69	95.5	126.5	179	228
	C10	100	133.5	179.5	250	323
D	D1	9	9	14	23	32
	D2	41.5	48	65	90	125
Weight	重量					

HF

HF-FM series

RATIO : 5.10.15 (單段 1-Stage)

入力法蘭 - 雙邊免鍵軸套

Input Flange - Double Clamping

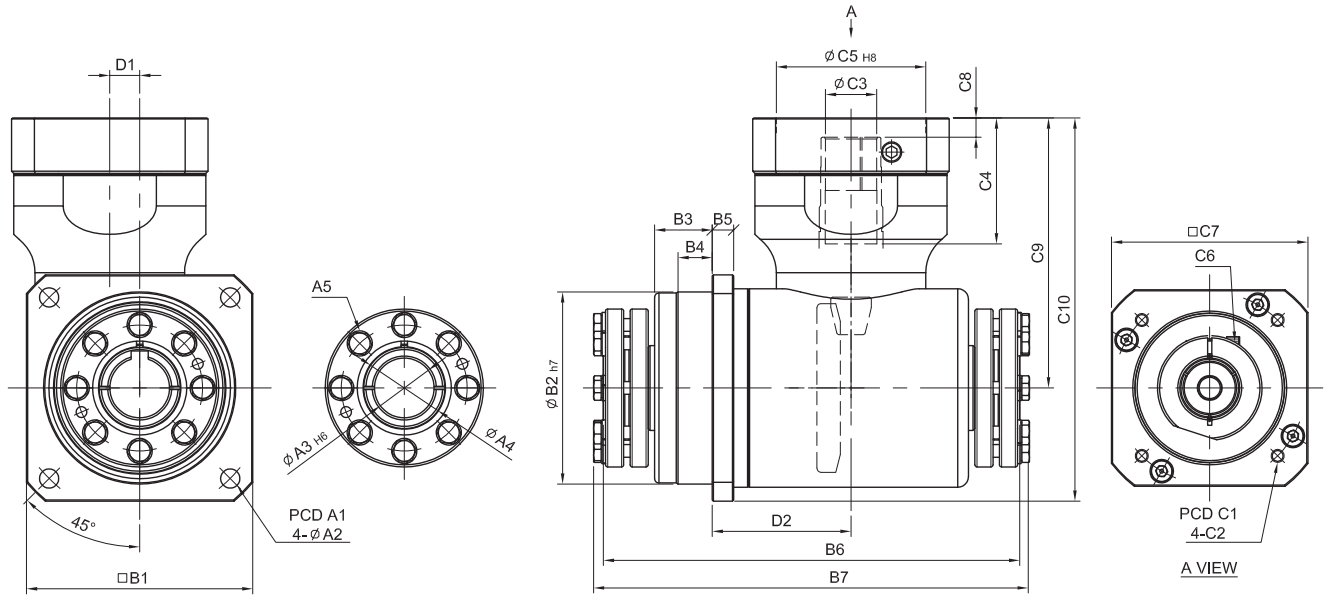

unit: mm

	Model Code	60	75	100	140	180
		A	A1	68	85	120
	A2	5.5	6.5	9	11	13
	A3	15	20	28	40	55
	A4	22	28	38	52	73
	A5	6-M6	6-M6	8-M6	8-M6	8-M6
B	B1	62	76	106	142	190
	B2	60	70	90	130	160
	B3	18	18	27	27	26
	B4	11	12	16	15.5	15.5
	B5	6	7	10	12	15
	B6	144	155	195	253	311
	B7	152	163	203	262	318.5
C	C1	46 · 60 · 63	70 · 75 · 90	90 · 100 · 115 · 145	115 · 145 · 165	145 · 165 · 200
	C2	M3 · M4 · M5	M4 · M5 · M6	M5 · M6 · M8	M6 · M8 · M10	M8 · M10 · M12
	C3	11	14	24	35	42
	C4	26	33	59	82	84.5
	C5	30 · 40 · 50	50 · 60 · 70	70 · 80 · 95 · 110	95 · 110 · 130	110 · 130 · 180
	C6	M4 x P0.7	M5 x P0.8	M6 x P1.0	M8 x P1.25	M10 x P1.5
	C7	46 · 55	64 · 70 · 80	92 · 110 · 130	122 · 130 · 150	146 · 150 · 190
	C8	5	6	9	10	10
	C9	69	95.5	126.5	179	228
	C10	100	133.5	179.5	250	323
D	D1	9	9	14	23	32
	D2	41.5	48	65	90	125
Weight	重量					

HF-FS series

RATIO : 5.10.15 (單段 1-Stage)

入力法蘭 - 單出力軸心

Input Flange - Single Output Shaft

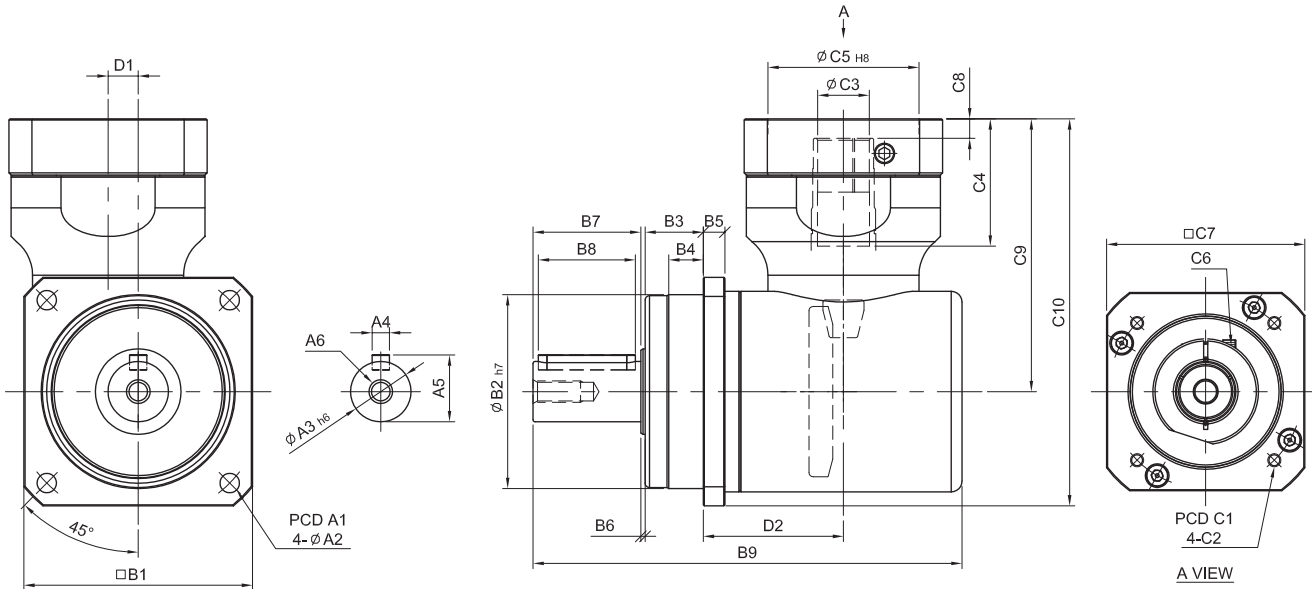

unit: mm

	Model Code	60	75	100	140	180
		A	A1	68	85	120
	A2	5.5	6.5	9	11	13
	A3	16	22	28	40	55
	A4	5	6	8	12	16
	A5	18	24.5	31	43	59
	A6	M5 x P0.8	M8 x P.125	M10 x 1.5	M12 x P1.75	M16 x P20
B	B1	62	76	106	142	190
	B2	60	70	90	130	160
	B3	18	18	27	27	26
	B4	11	12	16	15.5	15.5
	B5	6	7	10	12	15
	B6	2	2	2	3	3
	B7	28	36	50	70	82
	B8	25	32	45	60	70
	B9	129	147	199	260	326
C	C1	46 · 60 · 63	70 · 75 · 90	90 · 100 · 115 · 145	115 · 145 · 165	145 · 165 · 200
	C2	M3 · M4 · M5	M4 · M5 · M6	M5 · M6 · M8	M6 · M8 · M10	M8 · M10 · M12
	C3	11	14	24	35	42
	C4	26	33	59	82	84.5
	C5	30 · 40 · 50	50 · 60 · 70	70 · 80 · 95 · 110	95 · 110 · 130	110 · 130 · 180
	C6	M4 x P0.7	M5 x P0.8	M6 x P1.0	M8 x P1.25	M10 x P1.5
	C7	46 · 55	64 · 70 · 80	92 · 110 · 130	122 · 130 · 150	146 · 150 · 190
	C8	5	6	9	10	10
	C9	69	95.5	126.5	179	228
	C10	100	133.5	179.5	250	323
D	D1	9	9	14	23	32
	D2	41.5	48	65	90	125
Weight	重量					

HF

WE series

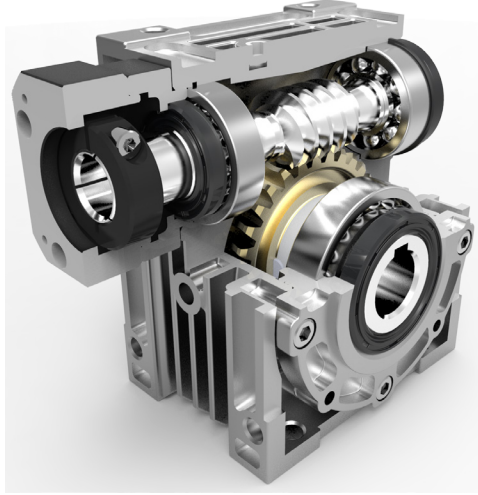

- 全系列小於 8 弧分
Backlash \leq 8 arcmin

適用於分度、定位、定寸，較不適用於連續運轉，連續運轉需注意溫升不能超出 50°C 以上。

Indication of Model Numbers

機種型號表示

WE	N		60	30	L	MOTOR
減速機機型 Type	出力軸 Output Shaft	出力法蘭 Output Flange	型號 Model	速比 Ratio	軸向 Shaft Dircetion	馬達型號 Motor Type
WE	S: 實心軸 Solid O: 中空軸 Hollow N: 免鍵軸套 Clamping	<input type="checkbox"/> 無 None F: 出力法蘭 Output Flange	30 40 50 60 70	1/5 1/10 1/15 1/20 1/30 1/40 1/50 1/60	R L	

Characteristic of WE Series

WE 系列產品特性

WE

Shaft Direction

軸向

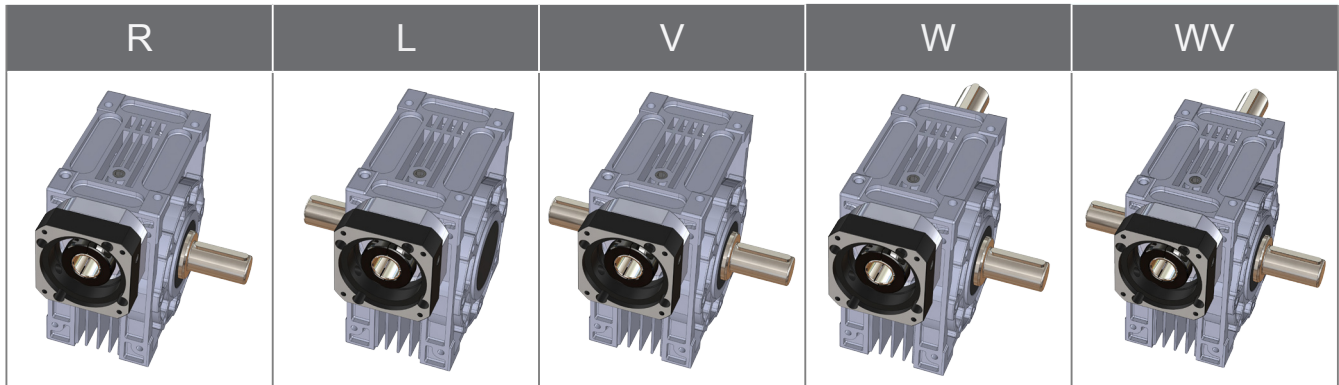

軸向

R: 右軸 (入力軸面對自己 · 出力軸在右方)

L: 左軸 (入力軸面對自己 · 出力軸在左方)

V: 單入力軸雙出力軸

W: 雙入力軸單出力軸

WV: 雙入力軸和雙出力軸

S: 特殊軸 (訂貨時請註明或附圖面)

Shaft Direction

R: Right Shaft (input shaft to the face; output shaft to the right)

L: Left Shaft (input shaft to the face; output shaft to the left)

V: Single Input Shaft & Double Output Shaft

W: Double Input Shaft & Single Output Shaft

WV: Double Input Shaft & Double Output Shaft

S: Special shaft (for any order, please specify your need clearly or attach drawings)

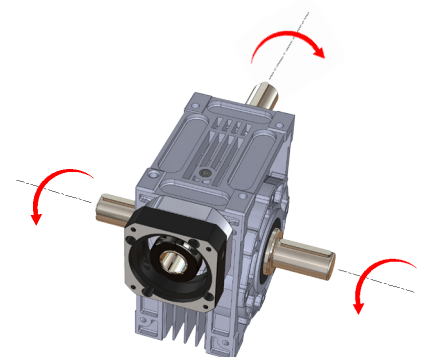
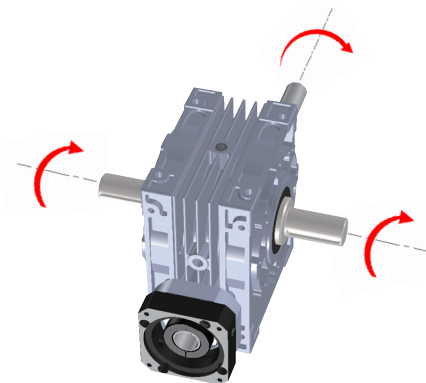

旋轉方向

Rotation Direction

旋向

設計上蝸桿使用右旋牙，故入力軸以順時針方向旋轉時，出力軸以逆時針方向旋轉，如需特殊旋向時請註明。

Rotary Direction

upper worm for right-directed thread, so the input shaft is rotating clockwise and the output shaft counterclockwise; for any rotating direction required, be sure to specify it.

Characteristic of WE Series

WE 系列產品特性

WE

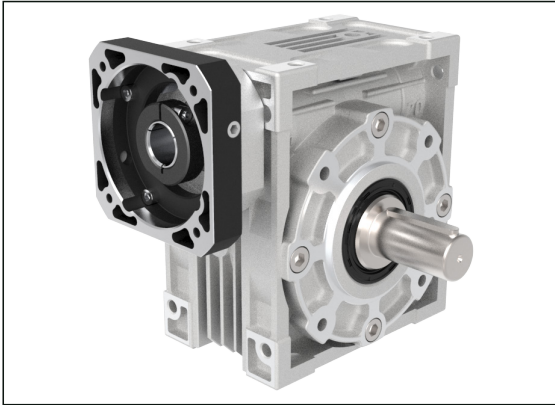

WES

○實心軸 Solid output shaft

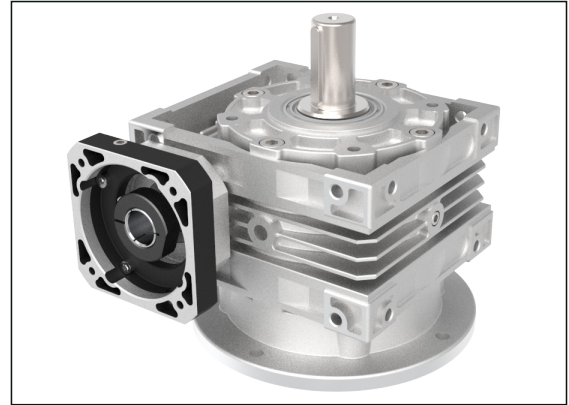

WESF

○實心軸 Solid output shaft

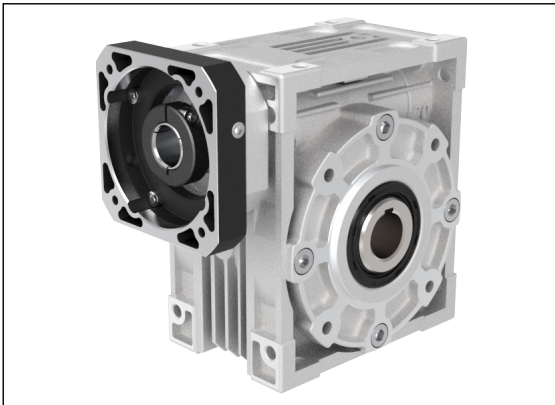

WEO

○中空軸 Hollow output shaft



WEOF

○中空軸 Hollow output shaft



WEN

○中空軸免鍵式 Clamping output shaft

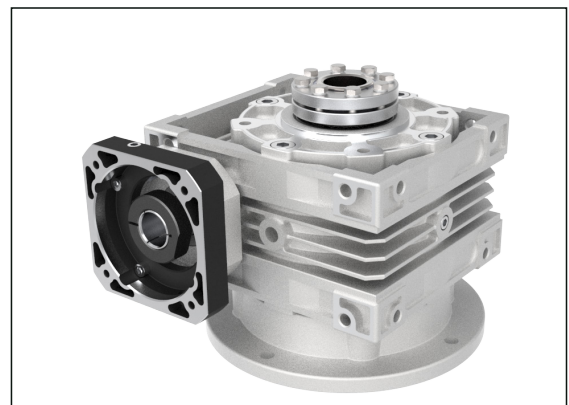

WENF

○中空軸免鍵式 Clamping output shaft

Characteristic of WE Series

WE 系列產品特性

WE

規格 Model No.	代號	單位 Unit	速比 Ratio	30	40	50	60	70
額定輸出扭矩 / Rated Output Torque (Nominal output torque)	T_{2N}	Nm	5	8.3	22.3	30.6	41.2	70.6
				90.3	92.3	92.6	92.6	93.6
10			8.8	20.7	41.9	65.9	92	
			83.7	86.6	89.6	90.1	90.5	
15			11.4	26.2	40.9	64.5	90	
			81.9	83.7	85.3	86.1	86.6	
20			9.52	22.6	40.7	63.5	106.1	
			72.3	76.6	81.7	82.4	85.1	
30			12.1	27.4	43.2	67.9	95	
			69.6	72.3	74.5	75.9	76.7	
40			9.2	24.3	43.8	69.1	111	
			56.8	66.3	69.2	70.3	74.3	
50			10.4	24	43.6	69.2	105.6	
			58.7	64.6	67.7	68.9	71.2	
60			9.6	20.5	36.1	58.3	100.5	
			54.6	56.8	59.3	61.3	68.8	
最大輸出扭矩 / Max. Output Torque 急停扭矩 / Emergency Stop Torque	T_{2NOT}	Nm	5~60	2 倍額定輸出扭矩 2 Times of Rated Output Torque				
額定輸入轉速 / Rated Input Speed	n_{1N}	rpm	5~60	2,000				
最大輸入轉速 / Max. Input Speed	n_{1B}	rpm	5~60	3,000				
背 隙 / Backlash Ps		arcmin	5~60	≤ 8				
容許徑向力 / Max. Radial Force	F_{2rB}	N	5~60	1,830	3,490	4,840	6,270	7,380
容許軸向力 / Max. Axial Force	F_{2aB}	N	5~60	915	1,745	2,420	3,135	3,690
使用壽命 / Service Life	L_H	hr	5~60	S5 周期運轉 : >12,000 (S1 連續運轉 : >6,000hrs) S5 Cycle Operation: >12,000 (S1 Continuous Operation: >6,000hrs)				
使用溫度 / Operating Temperature		°C	5~60	-15° C ~ +45° C				
潤 滑 / Lubrication			5~60	全合成潤滑油 Synthetic Grease				
防護等級 / Protection Class			5~60	IP65				
安裝方向 / Mounting Position			5~60	任意方向 Any				

WEO series

RATIO : 5.10.15.20.30.40.50.60

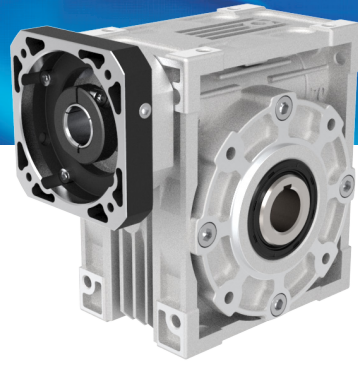

WE

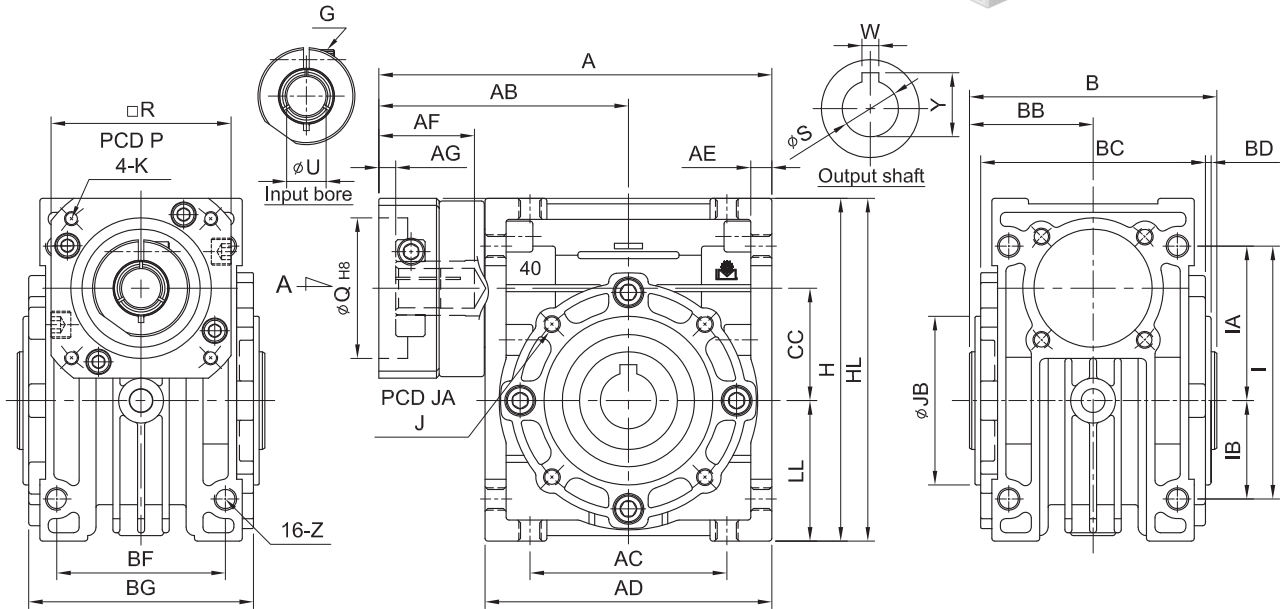

Model Code	A	AB	AC	AD	AE	AF	AG	B	BB	BC	BD	BF	BG	CC	LL	I	IA	IB	Z	H	Weight (KG)
30	108	68	55	80	6	32	5	65	32.5	60	2	45	58	30	40	72	45	27	M6	98	
40	140	89	70	102	7.5	34	6	88	44	80	2	60	72	40	50	90	55	35	M8	122	
50	158	98	80	120	8.5	41	6	98	50	94	3	70	85	50	60	105	65	40	M10	145	
60	195	122	100	146	10	59	9	108	54	102	3	85	103	60	75	136	83	53	M10	180	
70	219	134	120	170	12	59	9	128	64	118	3	90	110	70	85	150	90	60	M10	200	

unit : mm

Model Code	30	40	50	60	70	
OUTPUT SHAFT	S	14	20	25	30	
	Y	16.3	22.8	28.3	33.3	
	W	5	6	8	8	8
	J	8-M6 x P1.0	12-M6 x P1.0	12-M6 x P1.0	12-M8 x P1.25	12-M10 x P1.5
	JA	65	77	95	120	140
	JB	55	60	70	80	90
MOTOR FLANGE & INPUT BORE	P	46、60、63	70、75、90	70、75、90	90、100、115、145	90、100、115、145
	K	M3 x P0.5 M4 x P0.7 M5 x P0.8	M4 x P0.7 M5 x P0.8 M6 x P1.0	M4 x P0.7 M5 x P0.8 M6 x P1.0	M5 x P0.8 M6 x P1.0 M8 x P1.25	M5 x P0.8 M6 x P1.0 M8 x P1.25
	R	46、55	64、70、80	64、70、80	92、110、130	92、110、130
	G	M3 x P0.5	M5 x P0.8	M5 x P0.8	M6 x P1.0	M6 x P1.0
	Q	30、40、50	50、60、70	50、60、70	70、80、95、110	70、80、95、110
	U	8	14	19	24	24
	HL	100	122、125、130	145、150	181、190、200	210、220

括號之 U 尺寸為 1/5~1/40 可用。

WEN series

RATIO : 5.10.15.20.30.40.50.60

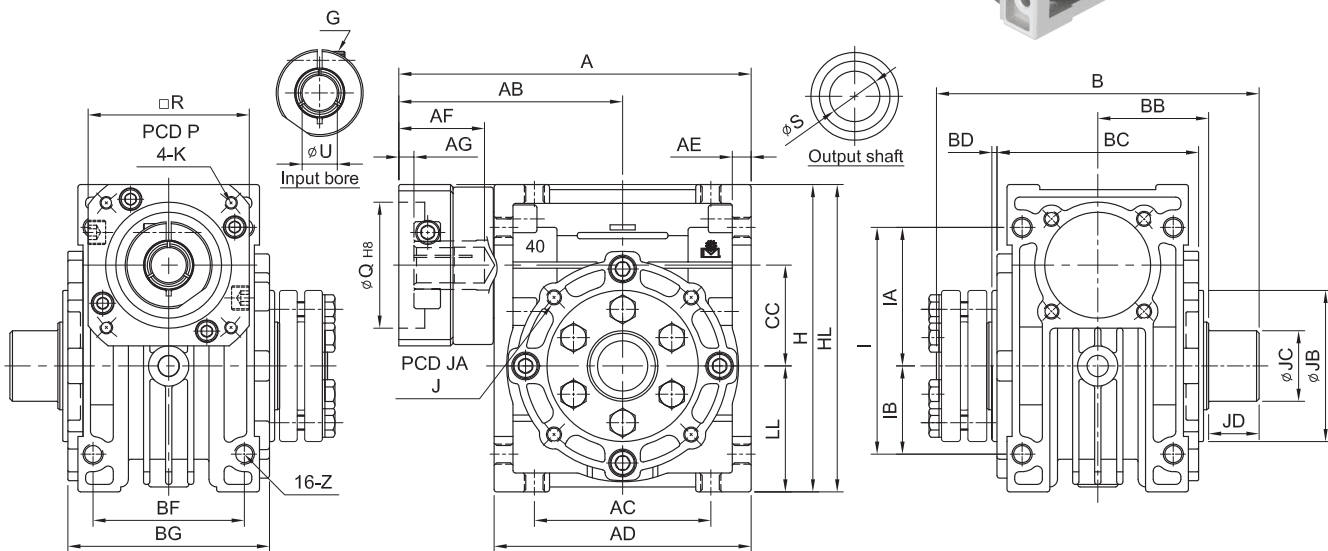
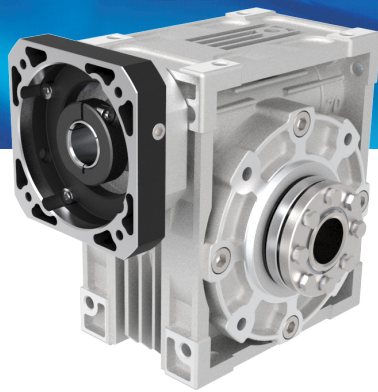

Model Code	A	AB	AC	AD	AE	AF	AG	B	BB	BC	BD	BF	BG	CC	LL	I	IA	IB	Z	H	Weight (KG)
30	108	68	55	80	6	32	5	108	36	60	2	45	58	30	40	72	45	27	M6	98	
40	140	89	70	102	7.5	34	6	128	46	80	2	60	72	40	50	90	55	35	M8	122	
50	158	98	80	120	8.5	41	6	146	53	94	3	70	85	50	60	105	65	40	M10	145	
60	195	122	100	146	10	59	9	154	57	102	3	85	103	60	75	136	83	53	M10	180	
70	219	134	120	170	12	59	9	172	65	118	3	90	110	70	85	150	90	60	M10	200	

unit : mm

Model Code	30	40	50	60	70	
OUTPUT SHAFT	S	14	20	25	30	
	J	8-M6 x P1.0	12-M6 x P1.0	12-M6 x P1.0	12-M8 x P1.25	12-M10 x P1.5
	JA	65	77	95	120	140
	JB	55	60	70	80	90
	JC	22	28	34	35	40
	JD	18	18	20	20	21
MOTOR FLANGE & INPUT BORE	P	46、60、63	70、75、90	70、75、90	90、100、115、145	90、100、115、145
	K	M3 x P0.5 M4 x P0.7 M5 x P0.8	M4 x P0.7 M5 x P0.8 M6 x P1.0	M4 x P0.7 M5 x P0.8 M6 x P1.0	M5 x P0.8 M6 x P1.0 M8 x P1.25	M5 x P0.8 M6 x P1.0 M8 x P1.25
	R	46、55	64、70、80	64、70、80	92、110、130	92、110、130
	G	M3 x P0.5	M5 x P0.8	M5 x P0.8	M6 x P1.0	M6 x P1.0
	Q	30、40、50	50、60、70	50、60、70	70、80、95、110	70、80、95、110
	U	8	14	19	24	24
	HL	100	122、125、130	145、150	181、190、200	210、220

括號之 U 尺寸為 1/5~1/40 可用。

WESF series

RATIO : 5.10.15.20.30.40.50.60



WE

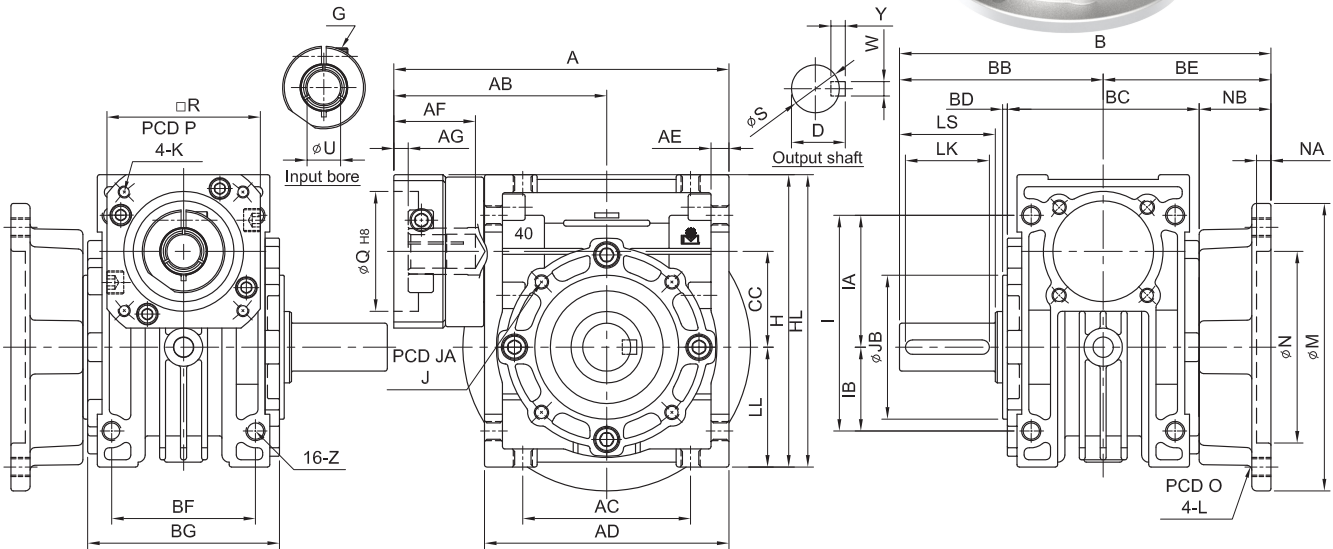

Model Code	A	AB	AC	AD	AE	AF	AG	B	BB	BC	BD	BE	BF	BG	NB	CC	LL	I	IA	IB	Z	H	Weight (KG)
30	108	68	55	80	6	32	5	127.5	67.5	60	2	60	45	58	30	30	40	72	45	27	M6	98	
40	140	89	70	102	7.5	34	6	155	85	80	2	70	60	72	30	40	50	90	55	35	M8	122	
50	158	98	80	120	8.5	41	6	180	100	94	3	80	70	85	33	50	60	105	65	40	M10	145	
60	195	122	100	146	10	59	9	205	105	102	3	100	85	103	49	60	75	136	83	53	M10	180	
70	219	134	120	170	12	59	9	225	125	118	3	100	90	110	41	70	85	150	90	60	M10	200	

unit : mm

Model Code	30	40	50	60	70	
OUTPUT SHAFT	S	16	20	25	30	
	Y	5	6	7	7	
	W	5	6	8	8	
	D	18	22.5	28	28	33
	LS	35	40	50	50	60
	LK	30	35	45	45	55
	J	8-M6 x P1.0	12-M6 x P1.0	12-M6 x P1.0	12-M8 x P1.25	12-M10 x P1.5
	JA	65	77	95	120	140
	JB	55	60	70	80	90
	N	70	80	95	130	150
	NA	5	6	6	7	7
	O	85	100	120	160	185
	L	M6 x P1.0	M8 x P1.25	M10 x P1.5	M10 x P1.5	M12 x P1.75
M	100	120	140	180	210	
MOTOR FLANGE & INPUT BORE	P	46、60、63	70、75、90	70、75、90	90、100、115、145	90、100、115、145
	K	M3 x P0.5 M4 x P0.7 M5 x P0.8	M4 x P0.7 M5 x P0.8 M6 x P1.0	M4 x P0.7 M5 x P0.8 M6 x P1.0	M5 x P0.8 M6 x P1.0 M8 x P1.25	M5 x P0.8 M6 x P1.0 M8 x P1.25
	R	46、55	64、70、80	64、70、80	92、110、130	92、110、130
	G	M3 x P0.5	M5 x P0.8	M5 x P0.8	M6 x P1.0	M6 x P1.0
	Q	30、40、50	50、60、70	50、60、70	70、80、95、110	70、80、95、110
	U	8	14	19	24	24
	HL	100	122、125、130	145、150	181、190、200	210、220

括號之 U 尺寸為 1/5~1/40 可用。

WEOF series

RATIO : 5.10.15.20.30.40.50.60

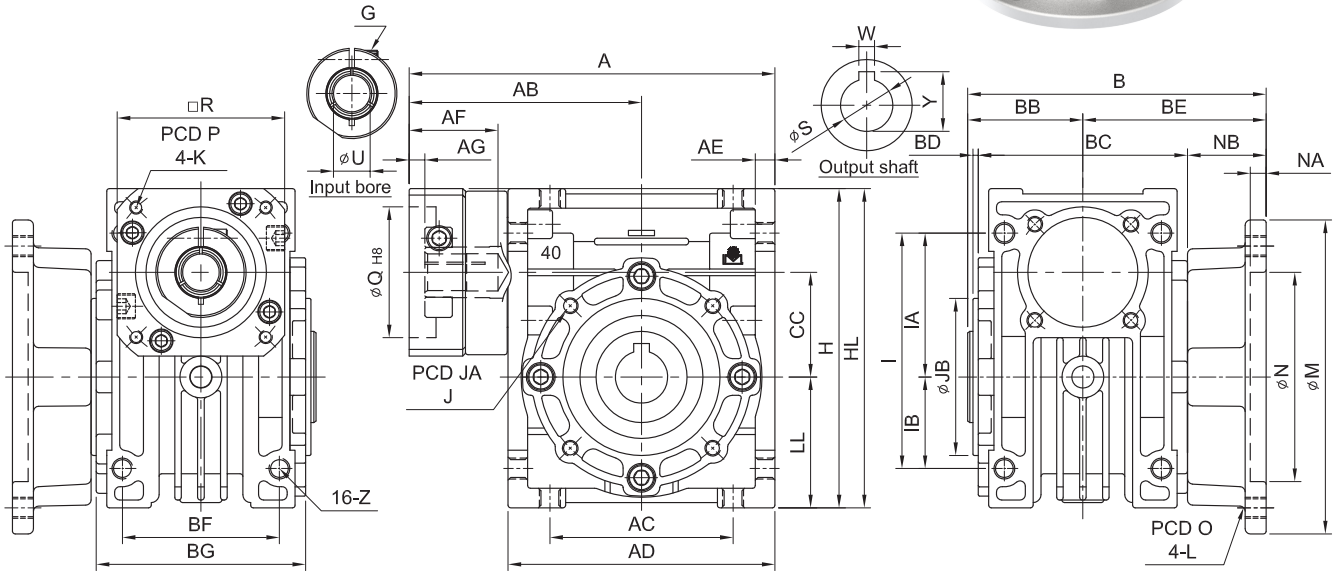
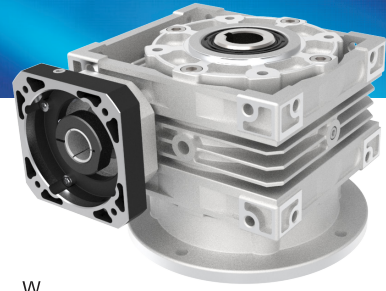

Model Code	A	AB	AC	AD	AE	AF	AG	B	BB	BC	BD	BE	BF	BG	NB	CC	LL	I	IA	IB	Z	H	Weight (KG)
30	108	68	55	80	6	32	5	92.5	32.5	60	2	60	45	58	30	30	40	72	45	27	M6	98	
40	140	89	70	102	7.5	34	6	114	44	80	2	70	60	72	30	40	50	90	55	35	M8	122	
50	158	98	80	120	8.5	41	6	130	49	94	3	80	70	85	33	50	60	105	65	40	M10	145	
60	195	122	100	146	10	59	9	154	54	102	3	100	85	103	49	60	75	136	83	53	M10	180	
70	219	134	120	170	12	59	9	164	64	118	3	100	90	110	41	70	85	150	90	60	M10	200	

unit : mm

Code	Model	30	40	50	60	70
OUTPUT SHAFT	S	14	20	25	25	30
	Y	16.3	22.8	28.3	28.3	33.3
	W	5	6	8	8	8
	J	8-M6 x P1.0	12-M6 x P1.0	12-M6 x P1.0	12-M8 x P1.25	12-M10 x P1.5
	JA	65	77	95	120	140
	JB	55	60	70	80	90
	N	70	80	95	130	150
	NA	5	6	6	7	7
	O	85	100	120	160	185
	L	M6 x P1.0	M8 x P1.25	M10 x P1.5	M10 x P1.5	M12 x P1.75
M	100	120	140	180	210	
MOTOR FLANGE & INPUT BORE	P	46、60、63	70、75、90	70、75、90	90、100、115、145	90、100、115、145
	K	M3 x P0.5 M4 x P0.7 M5 x P0.8	M4 x P0.7 M5 x P0.8 M6 x P1.0	M4 x P0.7 M5 x P0.8 M6 x P1.0	M5 x P0.8 M6 x P1.0 M8 x P1.25	M5 x P0.8 M6 x P1.0 M8 x P1.25
	R	46、55	64、70、80	64、70、80	92、110、130	92、110、130
	G	M3 x P0.5	M5 x P0.8	M5 x P0.8	M6 x P1.0	M6 x P1.0
	Q	30、40、50	50、60、70	50、60、70	70、80、95、110	70、80、95、110
	U	8	14	19	24	24
	HL	100	122、125、130	145、150	181、190、200	210、220

括號之 U 尺寸為 1/5~1/40 可用。

WENF series

RATIO : 5.10.15.20.30.40.50.60

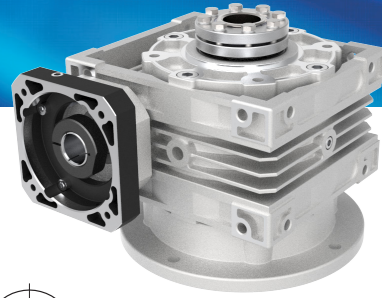

WE

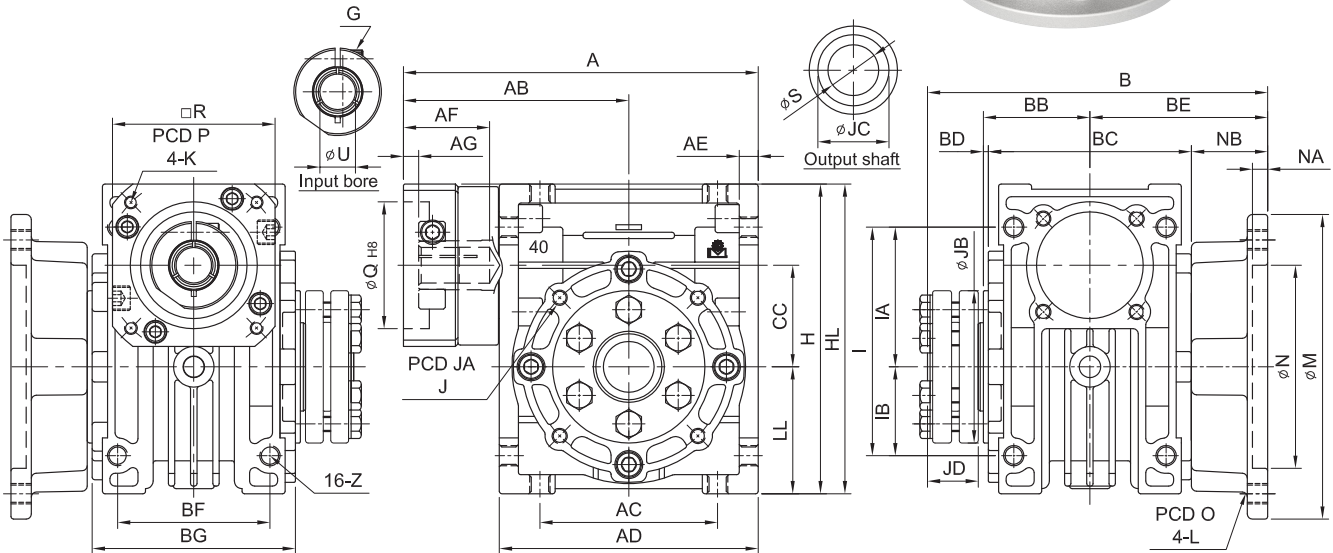

Model Code	A	AB	AC	AD	AE	AF	AG	B	BB	BC	BD	BE	BF	BG	NB	CC	LL	I	IA	IB	Z	H	Weight (KG)
30	108	68	55	80	6	32	5	114	32.5	60	2	60	45	58	30	30	40	72	45	27	M6	98	
40	140	89	70	102	7.5	34	6	134	44	80	2	70	60	72	30	40	50	90	55	35	M8	122	
50	158	98	80	120	8.5	41	6	153	49	94	3	80	70	85	33	50	60	105	65	40	M10	145	
60	195	122	100	146	10	59	9	177	54	102	3	100	85	103	49	60	75	136	83	53	M10	180	
70	219	134	120	170	12	59	9	186	64	118	3	100	90	110	41	70	85	150	90	60	M10	200	

unit : mm

Model Code	30	40	50	60	70	
OUTPUT SHAFT	S	14	20	25	30	
	J	8-M6 x P1.0	12-M6 x P1.0	12-M6 x P1.0	12-M8 x P1.25	12-M10 x P1.5
	JA	65	77	95	120	140
	JB	55	60	70	80	90
	JC	22	28	34	35	40
	JD	20	20	21	21	22
	N	70	80	95	130	150
	NA	5	6	6	7	7
	O	85	100	120	160	185
	L	M6 x P1.0	M8 x P1.25	M10 x P1.5	M10 x P1.5	M12 x P1.75
M	100	120	140	180	210	
MOTOR FLANGE & INPUT BORE	P	46、60、63	70、75、90	70、75、90	90、100、115、145	90、100、115、145
	K	M3 x P0.5 M4 x P0.7 M5 x P0.8	M4 x P0.7 M5 x P0.8 M6 x P1.0	M4 x P0.7 M5 x P0.8 M6 x P1.0	M5 x P0.8 M6 x P1.0 M8 x P1.25	M5 x P0.8 M6 x P1.0 M8 x P1.25
	R	46、55	64、70、80	64、70、80	92、110、130	92、110、130
	G	M3 x P0.5	M5 x P0.8	M5 x P0.8	M6 x P1.0	M6 x P1.0
	Q	30、40、50	50、60、70	50、60、70	70、80、95、110	70、80、95、110
	U	8	14	19	24	24
	HL	100	122、125、130	145、150	181、190、200	210、220

括號之 U 尺寸為 1/5~1/40 可用。

Technical Information

技術資料

潤滑油

當實際工作環境溫度超過表格中所記載的範圍時，須依據其實際工作環境而做不同之因應措施或與原廠技術人員連繫。

當工作環境低於攝氏 -15°C 或高於 45°C 時，必須更換耐熱油封。

當工作環境低於攝氏 0°C 時，必須考慮下列條件：

- 1 — 使用的馬達必須適合在低溫環境中工作。
- 2 — 馬達的功率必須要滿足在低溫起動時較大的扭矩要求。
- 3 — 在設備剛使用時，潤滑油的黏度會有較高的問題時，應該先讓機器空載運轉幾分鐘再加負載，避免導致設備故障。

最初使用 100 小時後，洗淨內部、換上新油以後每 2000 小時換油，而更換時間也因看實際操作環境有所變動。

Lubrication

In cases of ambient temperatures not envisaged in the table, call our Technical Service.

In the case of temperatures under -15°C or over 45°C it is necessary to use oil seals with special properties.

For operating ranges with temperatures under 0°C it is necessary to consider the following:

- 1-The motors need to be suitable for operation at the envisaged ambient temperature.
- 2-The power of the electric motor needs to be adequate for exceeding the higher starting torques required.
- 3-During the early stages of service, problems of lubrication may arise due to the high level of viscosity taken on by the oil and so it is wise to have a few minutes of rotation under no load.

After Initial 100 hours of usage, the interior of the reducing gear should be cleaned up and refill new oil.

And then, after every 2000 hours of usage replace new oil again. The period depends on the type of service and the environment where the reduction unit works.

WE 系列 WE Series

Model	C.C.	油淨重 (公克 g)
30#	30c.c.	25
40#	70c.c.	70
50#	140c.c.	150
60#	260c.c.	285
70#	360c.c.	390

Technical Information

技術資料

安裝與操作限制

如果須使用其它的安裝方式或者特殊的輸入轉數時，請參考下面附表裡面的各個相對參數。

此外，當使用者遇到下面所列的任何情況時也必須跟原廠技術人員聯繫：

- 使用條件超出額定轉速時。
- 使用條件超出額定扭矩時。
- 當減速機出現故障時有可能導致使用者受傷的情況時。
- 將安裝於旋轉慣性特別大的設備上時。
- 將用於起重的捲揚機上 (需要逆止特性) 時。
- 當減速機外殼會承受高度動態的負載時。
- 當工作環境超過攝氏 -5 度到 +40 度的範圍內時。
- 將安裝於有腐蝕性化學品的環境中。
- 將安裝在鹽份濕度較高的環境中。
- 輻射性高的環境中。
- 安裝於氣壓異於正常大氣壓力的環境中。

避免把減速機 (整臺或部分) 浸在水裡或其它液體中。

實際使用時的最高負載扭矩 (*) 絕對不能超過性能表上的額定扭矩 (當 f.s.=1) 的三倍。

(*) 所述的參數是指能承受瞬間短暫的過載，這種情況常出現在滿載啟動、剎車、震動或其它動態操作環境中。

Critical applications

For other mounting positions and/or particular input speeds, refer to the tables that highlight different critical situations for each size of reduction unit.

It is also necessary to take due consideration of and carefully assess the following applications by calling our Technical Service:

-
-
- Use in services that could be hazardous for people if the reduction unit fails.
- Applications with especially high inertia.
- Use as a lifting winch.
- Applications with high dynamic strain on the case of the reduction unit.
- In places with T° under -5° C or over 40° C.
- Use in chemically aggressive environments.
- Use in a salty environment.
- Use in radioactive environments.
- Use in environments pressures other than atmospheric pressure.

Avoid applications where even partial immersion of the reduction unit is required.

The maximum torque (*) that the gear reducer can support must not exceed three times the nominal torque (f.s.=1) stated in the performance tables.

(*) intended for momentary overloads due to starting at full load, braking, shocks or other causes, particularly those that are dynamic.

Technical Information

技術資料

安裝注意事項

當安裝減速機時，請注意下列的事項：

- 減速機必須牢固地安裝在機器上，避免有任何鬆動或振動的情況。
- 將減速機安裝到機器上之前，必須再次確認減速機的輸出軸旋轉方向是否正確。
- 如果減速機在使用前已經放置了一段時間 (4 到 6 個月)，而油封又沒有浸在潤滑油中或給予應有之保護措施，建議應該把油封更換，因為有可能油封已經黏在軸上，甚至可能失去彈性而不能發揮正常之功能。
- 請盡量避免把減速機放置及安裝在強烈陽光之下，或者在極端惡劣的環境之下，如有可能盡量給予減速機防護措施，以增加使用壽命。
- 盡量為馬達的散熱風扇提供足夠的流通空氣，以免影響散熱的效率。
- 減速機的標準工作環境是從攝氏 -15 度到 $+45$ 度，如超過這範圍時，請與原廠技術人員聯繫。
- 各種零件 (滑輪、齒輪、聯軸器、軸等) 必須安裝在實心或空心軸上，該用專用的螺紋孔或其它工具以確保正確安裝而不會損壞軸承或減速器外端的所有零件。並以潤滑油來潤滑接觸表面避免卡死或氧化。
- 啟動時必須逐漸啟動，不要立即把負載提到最高，該逐步增加。
- 如有任何在減速機旁的零件、物體或材料會因漏出的油而遭損壞時，應安裝特別的保護或遮擋。

Installation

To install the reduction unit it is necessary to note the following recommendations:

- The mounting on the machine must be stable to avoid any vibration.
- Check the correct direction of rotation of the reduction unit output shaft before fitting the unit to the machine.
- In the case of particularly lengthy periods of storage (4/6 months), if the oil seal is not immersed in the lubricant inside the unit, it is recommended to change it since the rubber could stick to the shaft or may even have lost the elasticity it needs to function properly.
- Whenever possible, protect the reduction unit against solar radiation and bad weather.
- Ensure the motor cools correctly by assuring good passage of air from the fan side.
- In the case of ambient temperatures $< 15^{\circ}\text{C}$ or $> +45^{\circ}\text{C}$ call the Technical Services.
- The various parts (pulleys, gear wheels, couplings, shafts, etc.) must be mounted on the solid or hollow shafts using special threaded holes or other systems that anyhow ensure correct operation without risking damage to the bearings or external parts of the units. Lubricate the surfaces in contact to avoid seizure or oxidation.
- Starting must take place gradually, without immediately applying the maximum load.
- When there are parts, objects or materials under the motor drive that can be damaged by even limited spillage of oil, special protection should be fitted.

Technical Information

技術資料

操作系數

減速機的操作系數 f.s. 是取決於減速機實際操作的運轉狀況。

正確選擇最合適的使用系數時，必須考慮到下列的幾種因素：

- 運轉機器的負載類型：A — B — C
- 每日運轉的時間：小時 / 每天 (Δ)
- 啟動的頻率：啟動次數 / 小時。(*)

- 負載類型： A — 均勻負載 $fa \leq 0.3$
 B — 中等衝擊 $fa \leq 3$
 C — 劇烈衝擊 $fa \leq 10$

$fa = Je/Jm$

— Je (kgm²) 驅動軸上的外圍轉動慣量

— Jm (kgm²) 馬達的轉動慣量

如果 $fa > 10$ 請與原裝技術人員聯繫。

A — 輕負載的螺旋輸送機·風扇裝備線·輕負載輸送帶·小型攪拌器·升降機·清洗機·罐裝機·控制機。

B — 卷揚機·木材加工進料機·貨物升降機·平衡器·絞螺紋機器·中型攪拌器·重型輸送帶·絞盤·滑動閘門·刮料機·包裝機械·混凝土攪拌機·吊車驅動裝置·銑床·摺床·齒輪泵。

C — 大型攪拌機·剪床·沖壓機·離心機·旋轉式支撐架·重型絞盤和起重機·磨床·碎石機·斗式挖土機·鑽床·衝床·凸輪壓力機·摺床·轉盤·滾桶清潔裝置·驅動器·粉碎機。

Service factor

The service factor (f.s.) depends on the operating conditions the reduction unit is subjected to.

The parameters that need to be taken into consideration to select the most adequate service factor correctly comprise:

- type of load of the operated machine : A - B - C
- length of daily operating time : hours/day (Δ)
- start-up frequency : starts/hour (*)

- TYPE OF LOAD : A -uniform $fa \leq 0.3$
 B -moderate shocks $fa \leq 3$
 C -heavy shocks $fa \leq 10$

$fa = Je/Jm$

- fa factor of inertia

- Je (kgm²) moment of reduced external inertia at the drive-shaft

- Jm (kgm²) moment of inertia of motor

If $fa > 10$ call our Technical Service.

A -Screw feeders for light materials, fans, assembly lines, conveyor belts for light materials, small mixers, lifts, cleaning machines, fillers,control machines.

B -Winding devices, woodworking machine feeders, goods lifts, balancers, threading machines, medium mixers, conveyor belts for heavy materials, winches, sliding doors, fertilizer scrapers, packing machines, concrete mixers, crane mechanisms, milling cutters, folding machines, gear pumps.

C -Mixers for heavy materials, shears, presses, centrifuges, rotating supports, winches and lifts for heavy materials, grinding lathes, stone mills, bucket elevators, drilling machines, hammer mills, cam presses, folding machines, turntables, tumbling barrels, vibrators, shredders.

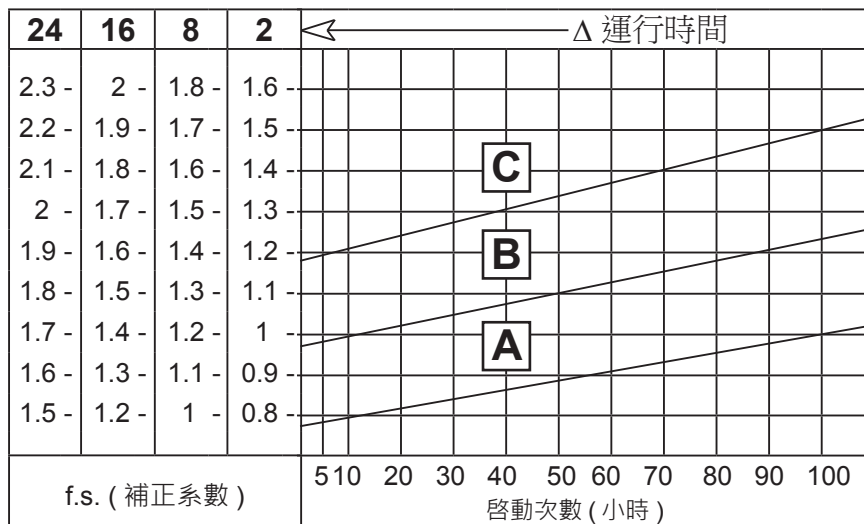

ANE series

ANE 系列可調背隙蝸輪減速機

雙導程設計·高扭力·高剛性·低噪音·低震動·低背隙 (0~6 弧分)

- 背隙調整容易·倍增精度壽命
- 特殊規格歡迎訂製
- 適用高精度傳動及分度·定位·定寸之應用
 - 工具機第四軸
 - 旋轉工作檯·分度盤
 - 機器人
 - 各式產業機械定位·定寸裝置



ANE Series Adjustable Backlash Worm Gear Reducer

Characteristic: dual-lead design, high output torque, high rigidity, low noise, low vibration and low backlash (0~6 arcmin).

- Easy to adjust backlash for increasing accuracy and service life.
- Customized specifications are available.
- Suitable for high-accuracy transmission system, indexing, positioning and sizing applications:
 - 4th-axis of machine tables
 - Rotary tables and index tables
 - Robots
 - Positioning and sizing devices of various industrial machinery

生產機型 Type & 速比 Raio :

- 40# · 1/20
- 50# · 1/30
- 60# · 1/40
- 70# · 1/50

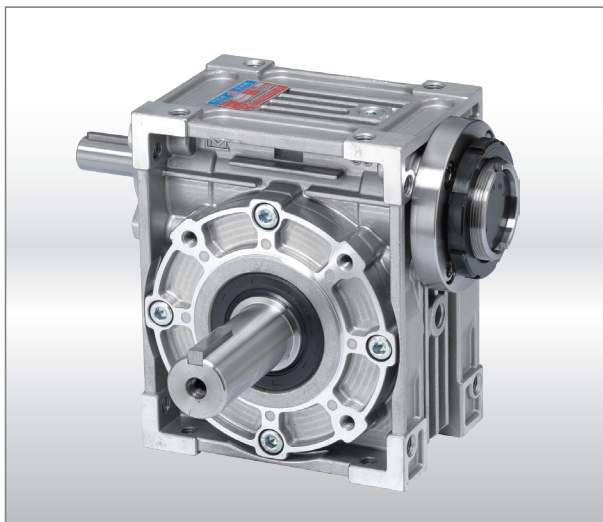

ANE

○ 實心軸傳動 Solid output shaft

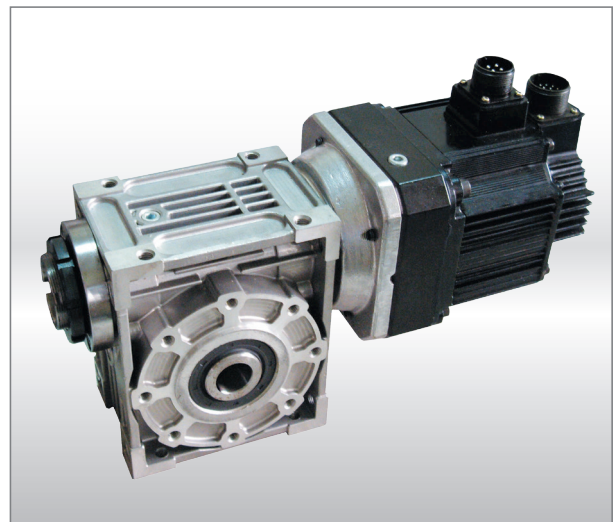

ANEOM

○ 中空軸傳動 Hollow output shaft

Characteristic of ANE Series

ANE 系列產品特性

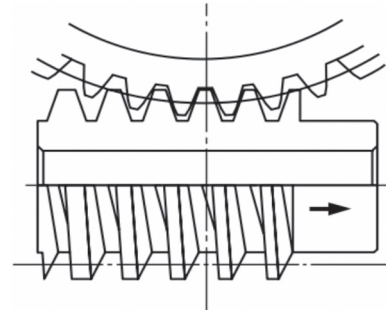

雙導程蝸桿傳動及齒隙調整原理

由於普通蝸桿蝸輪是用蝸桿沿蝸輪徑向移動來調整嚙合側隙，因而改變了傳動組的中心距，中心距的改變會引起齒面接觸情況變差，甚至加劇磨損，不利於保持蝸輪組的精度；而雙導程蝸桿是用蝸桿軸向移動來調整嚙合側隙，不會改變傳動組的中心距，可避免上述缺點。

雙導程蝸桿簡單說就是蝸桿的齒厚是變化的，左齒面與右齒面導程長度不同，使得齒厚形成有連續變化的齒形，蝸輪的齒面也為了與蝸桿配合，而製作成左右不同的齒面，這樣就可以調整蝸輪蝸桿的間隙達到最佳狀態。當使用過程由於蝸輪磨損，造成蝸輪蝸桿的間隙變大，可以通過調整蝸桿的軸向位置，使蝸輪蝸桿的間隙變小。

雙導程蝸桿傳動具有改變嚙合側隙的特點，能夠始終保持正確的嚙合關係；並且結構緊湊，調整方便，因而在要求連續精確分度的結構中被採用，以便調整嚙合側隙到最小程度。

Principle of Dual-lead Worm Transmission and Backlash Adjustment

The backlash adjustment on a conventional worm / worm gear set is made by moving the worm along the worm gear in radial direction, which may result in a change of center distance of the transmission set. Such change of center distance will cause poor contact between teeth, wearing and affection on accuracy of worm / worm gear set.

However, the backlash adjustment on a dual-lead worm is made by moving worm in axial direction, which does not change the distance of the transmission set and avoid above problems.

The dual-lead worm features varied teeth thickness. There is a different lead length between the right and left tooth faces, that creates a continuous teeth shapes. To properly engage with the worm, the teeth faces of worm gear are also designed with different right and left tooth faces. This permits backlash adjustment to achieve the best condition.

After a period of operation, if a backlash between worm and worm gear increases due to wear, it can be adjusted by moving the worm in axial direction until a proper backlash is obtained.

The dual-lead worm transmission allows for changing side backlash to keep correct teeth-engagement at all times. In addition, it has a compact structure and easy adjustment. Therefore, it is ideally suited for indexing devices that require continuous accuracy by adjusting teeth backlash to the minimum extent.

GT series

GT

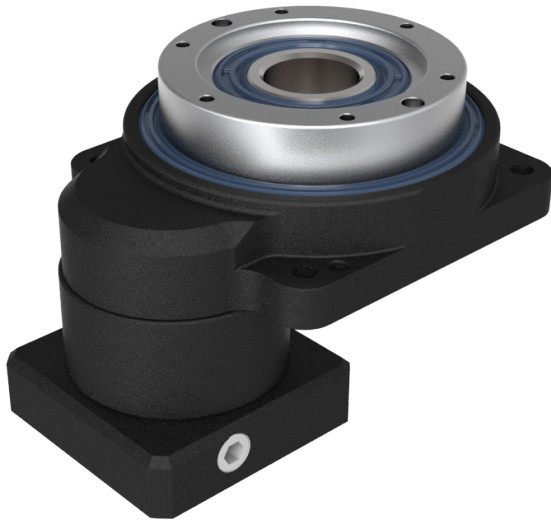

Indication of Model Numbers

機種型號表示

GT	-	60	B	-	10	-	MOTOR
減速機機型 Type		型號 Model	輸出平台支撐軸承 Output Table Supporting Bearing		速比 Ratio		馬達型號 Motor Type
GT		60 85 110 135 200 250	B: 深溝滾珠軸承 (60#~200#) Ball Bearing C: 交叉斜角滾柱軸承 (60#~200#) Crossed Roller Bearing H: 深溝滾珠軸承大中空 (60#) Ball Bearing 交叉斜角滾柱軸承大中空 Crossed Roller Bearing (85#~250#)		單段 1-Stage : 5, 10, 18 雙段 2-Stage : 25, 50, 100 ----- 輸出平台支撐軸承形式 H Output table supporting bearing type H 單段 1-Stage : 10, 18 雙段 2-Stage : 50, 100		

靜音

使用研磨等級螺旋齒輪實現順暢安靜地運轉。

Quiet operation

Grinding spiral bevel gear & Helical gears contribute to reduce vibration and noise.

高剛性、高扭矩

使用交叉斜角滾柱軸承，提高了剛性和扭矩。

High Rigidity & High Torque

High rigidity & high torque are achieved by crossed roller bearings.

高效率

效率在 98% 以上。

High Efficiency

Efficiency exceeds 98%.

Characteristic of GT Series

GT 系列產品特性

彈性電機連接

可搭配各廠牌伺服或步進電機。
輸入端與馬達的連結採用筒夾式的鎖緊機構，並經動力平衡分析，以確保輸入轉速下結合介面的同心度和平衡度，及零背隙的動力傳遞。

Flexible Motor Connection

The modular design of motor connection plate is suitable for any brand servomotor and stepmotor. The input-end and the motor are coupled through a collet locking mechanism. It has passed dynamical balance analysis to assure concentricity and balance on the connection and no backlash for power transmission while running at high speed.

軸承

採用高精密交叉斜角滾柱軸承，體積小、結構緊湊，可同時承載徑向及軸向負荷。
在軸向負荷較小的應用場合，亦可選用滾珠軸承

中空結構

配管、配線便利

Hollow Structure Design

Make it convenient for electric wiring or piping work.

螺旋齒輪設計

減速機構採用螺旋齒輪設計，齒形嚙合率為一般正齒輪的二倍以上，具有運轉平順、低噪音、高輸出扭矩和低背隙的特性。

Helical Gear Design

The speed reduction mechanism employs helical gears, which provides two times meshing rate of teeth when comparing with regular spur gears. In addition, it also Specification extremely smooth running, low noise, high torque output and low backlash.

高精度定位

重覆定位精度 $\pm 10 \text{ sec}$
回程間隙 $\leq 1 \text{ arcmin}$
動態齒隙差 2 arcmin

High Accuracy

Repetitive Positioning Accuracy $\pm 10 \text{ sec}$
Torsional Backlash $\leq 1 \text{ arcmin}$
Lost Motion 2 arcmin

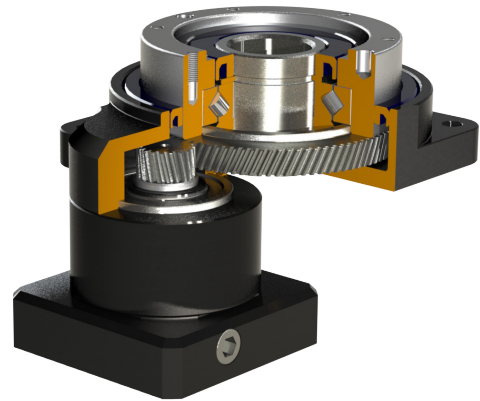

直接連結

轉盤面可與承載物直接鎖固

Direct Mounting of Workpiece

The rotating table allows for direct mounting of workpiece for added convenience in workpiece loading.

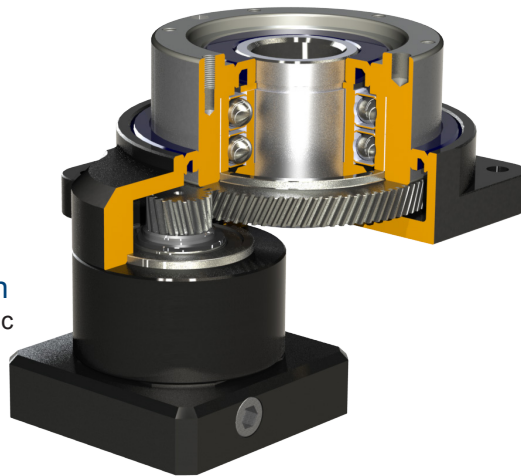

高精度加工

旋轉盤本體使用鋁合金材料，經高精密 CNC 加工，及檢測設備，確保各部之精密度。
齒輪經滲碳熱處理及齒輪研磨，精密度達 DIN6 級以內，齒面硬度達 HRC58~60 度。

High Precision Gear Machining

The housing of reducer is made by aluminum alloy, and precision machining by CNC machine. Precision teeth grinding assures gear accuracy reaches DIN6 class and carburized to hardness 58-60 HRC.

MODEL : GT-60B

RATIO : 5.10.18 (單段 1-Stage)

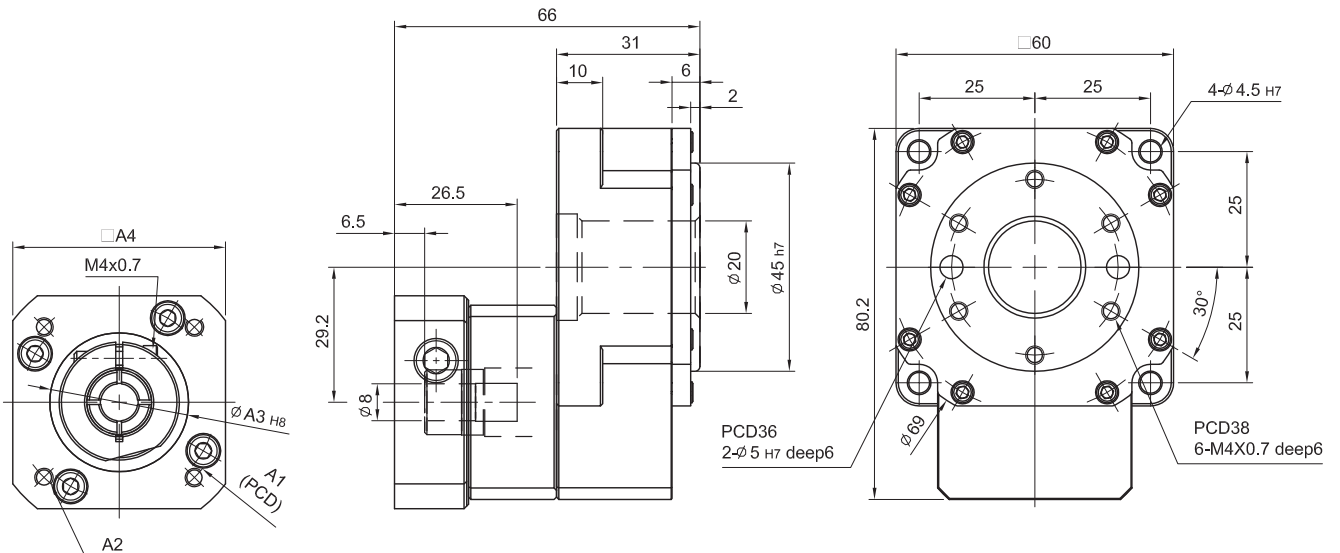
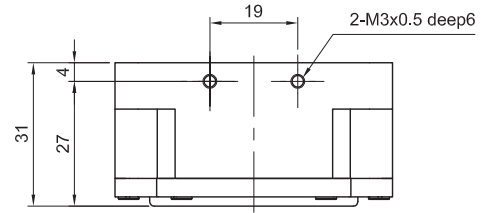
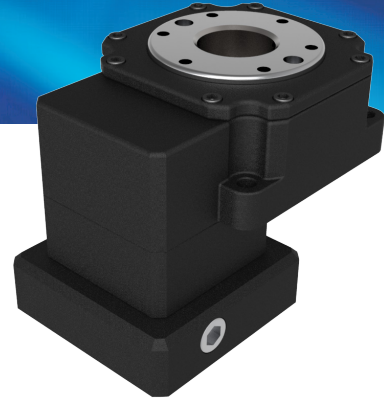

特性 Characteristic	代號	單位 Unit	GT-60B
輸出平台支撐軸承 / Output Table Supporting Bearing			深溝滾珠軸承 Ball Bearing
額定輸出扭矩 / Rated Output Torque		N.m	5
最大輸出扭矩 / Max. Output Torque 急停扭矩 / Emergency Stop Torque	T_{2NOT}	N.m	2 倍額定輸出扭矩 2 Time of Rated Output Torque
慣性慣量 / Inertia Moment		kg.m ²	777×10^{-7}
出力容許轉速 / Output Permissible Speed		rpm	300
回程間隙 / Torsional Backlash		arcmin	≤ 1
動態齒隙差 / Lost Motion		arcmin	2 (0.033°)
重覆定位精度 / Repetitive Positioning Accuracy		arcsec	± 10 (0.0028°)
容許載重 / Permissible Thrust Load		N	350
容許慣量載重 / Permissible Moment Load		N.m	7
工作台面偏擺 / Runout of Output Table Surface		mm	0.01
工作同心度 / Runout of Output Table Inner / Outer Diameter		mm	0.01
工作台平行度 / Parallelism of Output Table		mm	0.02
使用壽命 / Service Life	L_H	hr	S5 周期運轉 : >20,000 (S1 連續運轉 : >10,000 hrs) S5 Cycle Operation: >20,000 (S1 Continuous peration: >10,000 hrs)
防護等級 / Protection Class			IP 65
重量 / Weight		Kg	0.54

MODEL : GT-60B

RATIO : 25.50.100 (雙段 2-Stage)



Unit: mm

Model Code	60
A1	46 · 63 · 60
A2	M3 · M4 · M5
A3	30 · 40 · 50
A4	46 · 55

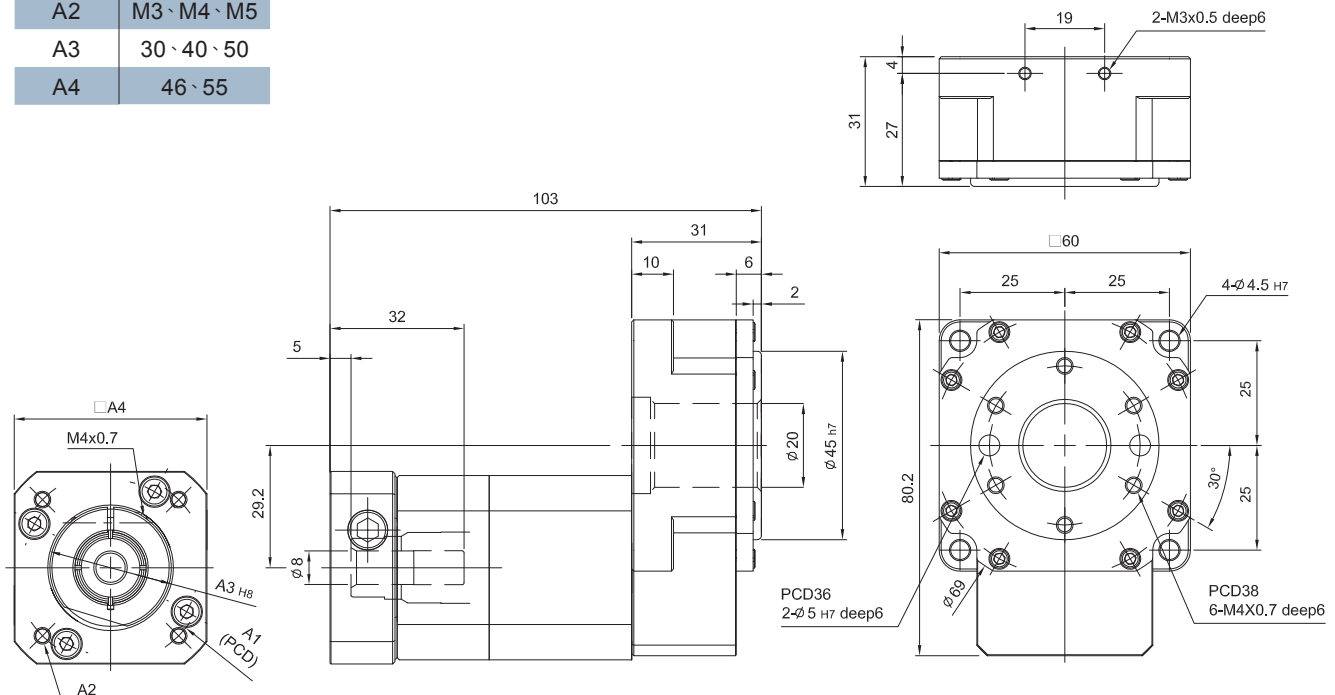

特性 Characteristic	代號	單位 Unit	GT-60B
輸出平台支撐軸承 / Output Table Supporting Bearing			深溝滾珠軸承 Ball Bearing
額定輸出扭矩 / Rated Output Torque		N.m	5
最大輸出扭矩 / Max. Output Torque 急停扭矩 / Emergency Stop Torque	T_{2NOT}	N.m	2 倍額定輸出扭矩 2 Time of Rated Output Torque
慣性慣量 / Inertia Moment		kg.m ²	777×10^{-7}
出力容許轉速 / Output Permissible Speed		rpm	300
回程間隙 / Torsional Backlash		arcmin	≤ 1
動態齒隙差 / Lost Motion		arcmin	2 (0.033°)
重覆定位精度 / Repetitive Positioning Accuracy		arcsec	±10 (0.0028°)
容許載重 / Permissible Thrust Load		N	350
容許慣量載重 / Permissible Moment Load		N.m	7
工作台面偏擺 / Runout of Output Table Surface		mm	0.01
工作同心度 / Runout of Output Table Inner / Outer Diameter		mm	0.01
工作台面平行度 / Parallelism of Output Table		mm	0.02
使用壽命 / Service Life	L_H	hr	S5 周期運轉 : >20,000 (S1 連續運轉 : >10,000 hrs) S5 Cycle Operation: >20,000 (S1 Continuous peration: >10,000 hrs)
防護等級 / Protection Class			IP 65
重量 / Weight		Kg	1.1

MODEL : GT-85B

RATIO : 5.10.18 (單段 1-Stage)

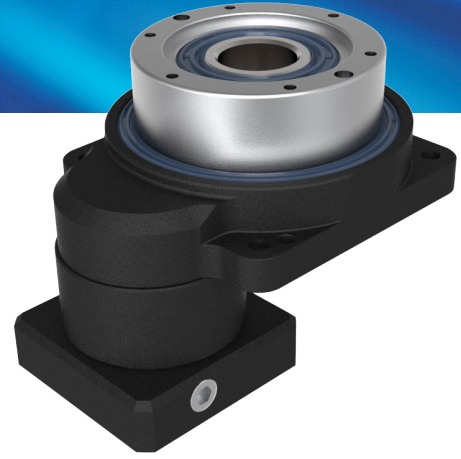

Unit: mm

Model Code	85
A1	46 · 63 · 60
A2	M3 · M4 · M5
A3	30 · 40 · 50
A4	46 · 55

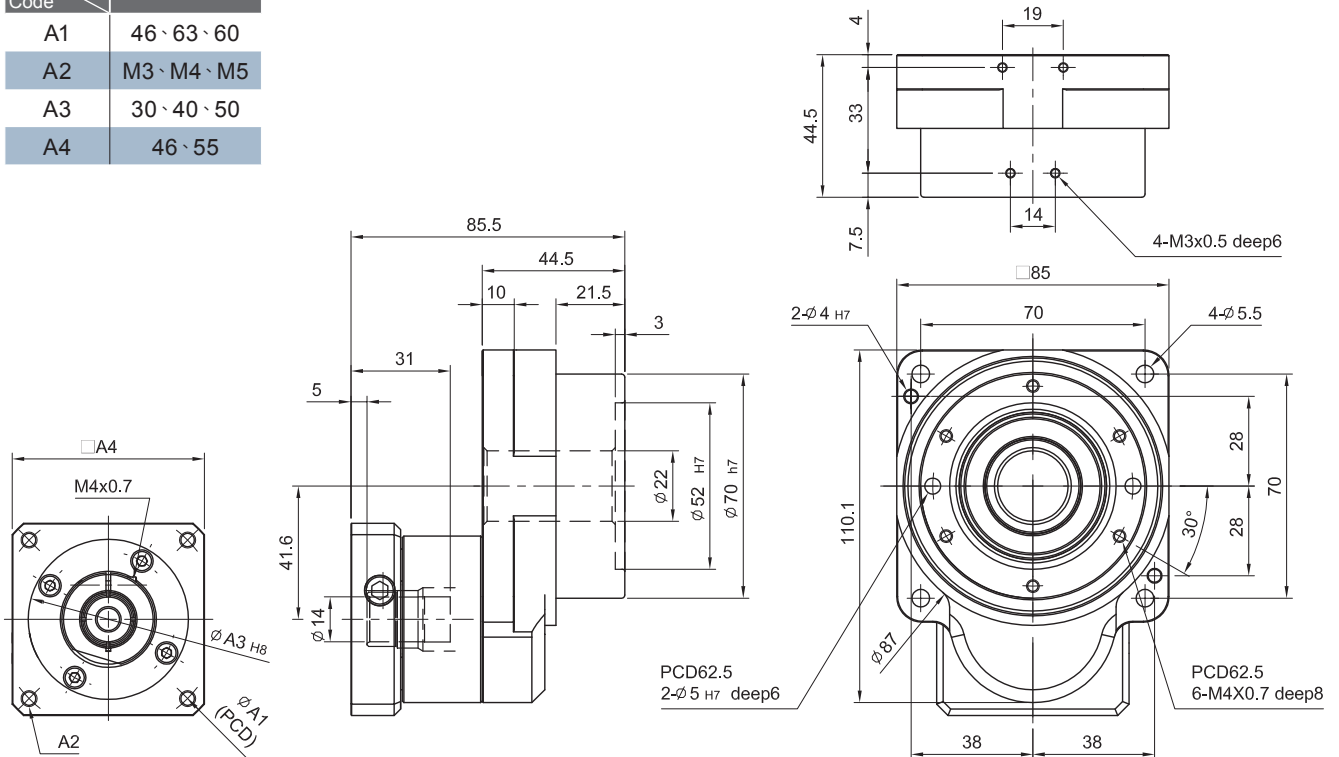

特性 Characteristic	代號	單位 Unit	GT-85B
輸出平台支撐軸承 / Output Table Supporting Bearing			深溝滾珠軸承 Ball Bearing
額定輸出扭矩 / Rated Output Torque		N.m	18
最大輸出扭矩 / Max. Output Torque 急停扭矩 / Emergency Stop Torque	T_{2NOT}	N.m	2 倍額定輸出扭矩 2 Time of Rated Output Torque
慣性慣量 / Inertia Moment		kg.m ²	$1,268 \times 10^{-6}$
出力容許轉速 / Output Permissible Speed		rpm	300
回程間隙 / Torsional Backlash		arcmin	≤ 1
動態齒隙差 / Lost Motion		arcmin	2 (0.033°)
重覆定位精度 / Repetitive Positioning Accuracy		arcsec	± 10 (0.0028°)
容許載重 / Permissible Thrust Load		N	600
容許慣量載重 / Permissible Moment Load		N.m	12
工作台面偏擺 / Runout of Output Table Surface		mm	0.01
工作合同心度 / Runout of Output Table Inner / Outer Diameter		mm	0.01
工作平台平行度 / Parallelism of Output Table		mm	0.02
使用壽命 / Service Life	L_H	hr	S5 周期運轉 : >20,000 (S1 連續運轉 : >10,000 hrs) S5 Cycle Operation : >20,000 (S1 Continuous peration : >10,000 hrs)
防護等級 / Protection Class			IP 65
重量 / Weight		Kg	1.17

MODEL : GT-85B

RATIO : 25.50.100 (雙段 2-Stage)



GT

Unit: mm

Model Code	85
A1	46 · 63 · 60
A2	M3 · M4 · M5
A3	30 · 40 · 50
A4	46 · 55

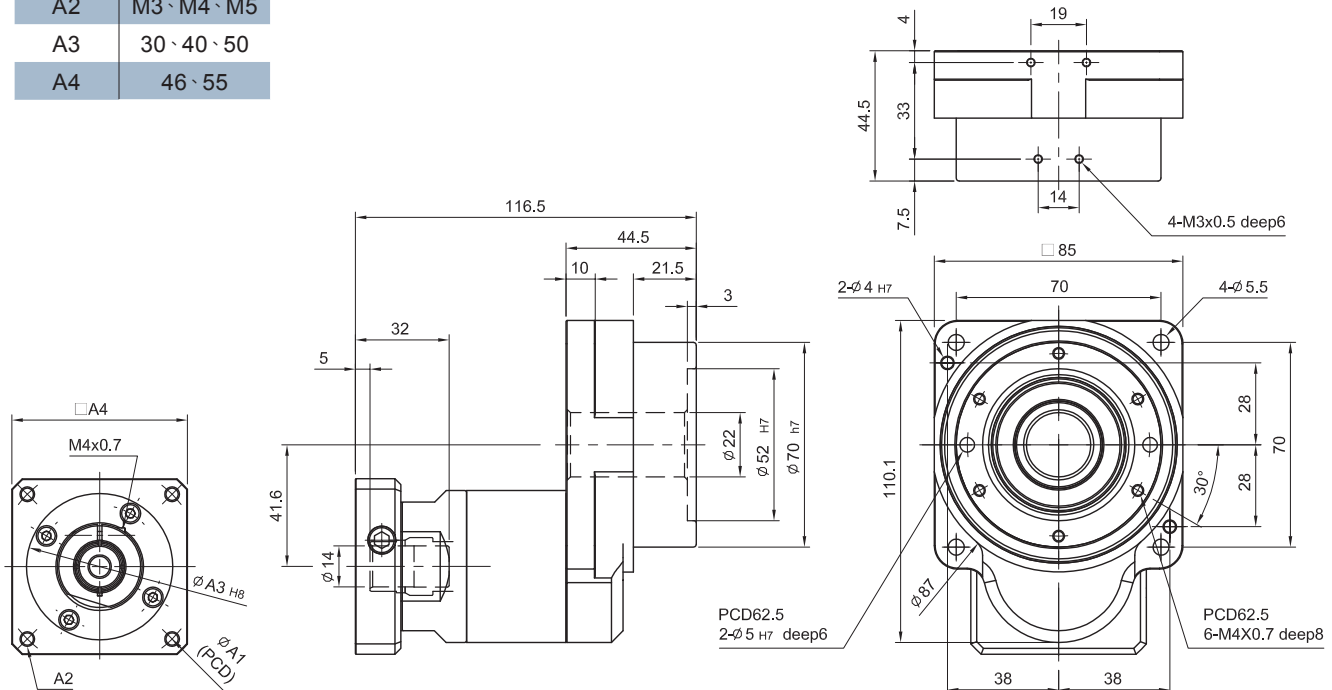

特性 Characteristic	代號	單位 Unit	GT-85B
輸出平台支撐軸承 / Output Table Supporting Bearing			深溝滾珠軸承 Ball Bearing
額定輸出扭矩 / Rated Output Torque		N.m	18
最大輸出扭矩 / Max. Output Torque 急停扭矩 / Emergency Stop Torque	T_{2NOT}	N.m	2 倍額定輸出扭矩 2 Time of Rated Output Torque
慣性慣量 / Inertia Moment		kg.m ²	1,268 x 10 ⁻⁶
出力容許轉速 / Output Permissible Speed		rpm	300
回程間隙 / Torsional Backlash		arcmin	≤ 1
動態齒隙差 / Lost Motion		arcmin	2 (0.033°)
重覆定位精度 / Repetitive Positioning Accuracy		arcsec	±10 (0.0028°)
容許載重 / Permissible Thrust Load		N	600
容許慣量載重 / Permissible Moment Load		N.m	12
工作台面偏擺 / Runout of Output Table Surface		mm	0.01
工作台同心度 / Runout of Output Table Inner / Outer Diameter		mm	0.01
工作台平行度 / Parallelism of Output Table		mm	0.02
使用壽命 / Service Life	L_H	hr	S5 周期運轉 : >20,000 (S1 連續運轉 : >10,000 hrs) S5 Cycle Operation : >20,000 (S1 Continuous peration : >10,000 hrs)
防護等級 / Protection Class			IP 65
重量 / Weight		Kg	1.95

MODEL : GT-110B

RATIO : 5.10.18 (單段 1-Stage)

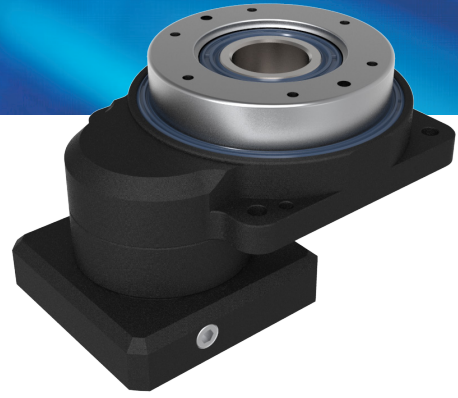

Unit: mm

Model Code	110
A1	70 · 75 · 90
A2	M4 · M5 · M6
A3	50 · 60 · 70
A4	64 · 70 · 80

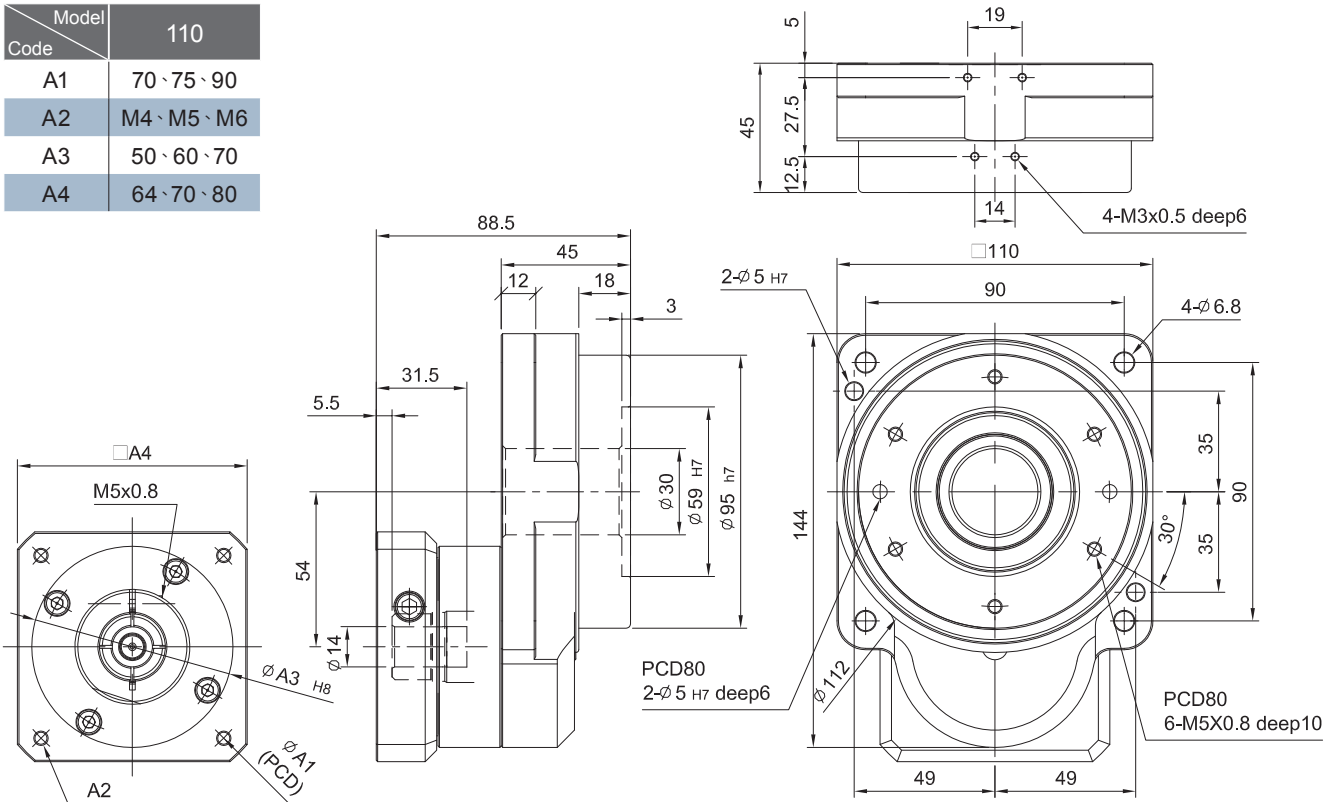

特性 Characteristic	代號	單位 Unit	GT-110B
輸出平台支撐軸承 / Output Table Supporting Bearing			深溝滾珠軸承 Ball Bearing
額定輸出扭矩 / Rated Output Torque		N.m	33
最大輸出扭矩 / Max. Output Torque 急停扭矩 / Emergency Stop Torque	T_{2NOT}	N.m	2 倍額定輸出扭矩 2 Time of Rated Output Torque
慣性慣量 / Inertia Moment		kg.m ²	1,562 x 10 ⁻⁶
出力容許轉速 / Output Permissible Speed		rpm	300
回程間隙 / Torsional Backlash		arcmin	≤ 1
動態齒隙差 / Lost Motion		arcmin	2 (0.033°)
重覆定位精度 / Repetitive Positioning Accuracy		arcsec	±10 (0.0028°)
容許載重 / Permissible Thrust Load		N	800
容許慣量載重 / Permissible Moment Load		N.m	16
工作台面偏擺 / Runout of Output Table Surface		mm	0.015
工作合同心度 / Runout of Output Table Inner / Outer Diameter		mm	0.015
工作平台平行度 / Parallelism of Output Table		mm	0.025
使用壽命 / Service Life	L_H	hr	S5 周期運轉 : >20,000 (S1 連續運轉 : >10,000 hrs) S5 Cycle Operation : >20,000 (S1 Continuous peration : >10,000 hrs)
防護等級 / Protection Class			IP 65
重量 / Weight		Kg	2.54

MODEL : GT-110B

RATIO : 25.50.100 (雙段 2-Stage)

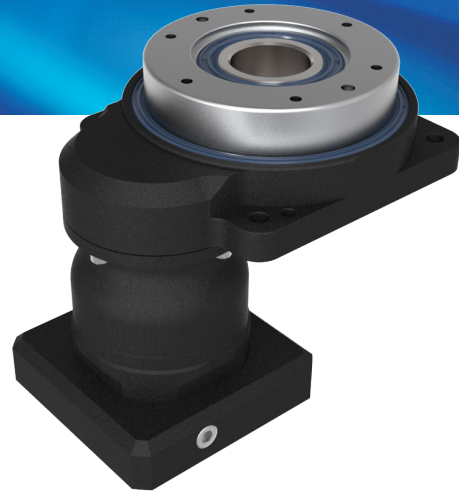

GT

Unit: mm

Model Code	110
A1	70 · 75 · 90
A2	M4 · M5 · M6
A3	50 · 60 · 70
A4	64 · 70 · 80

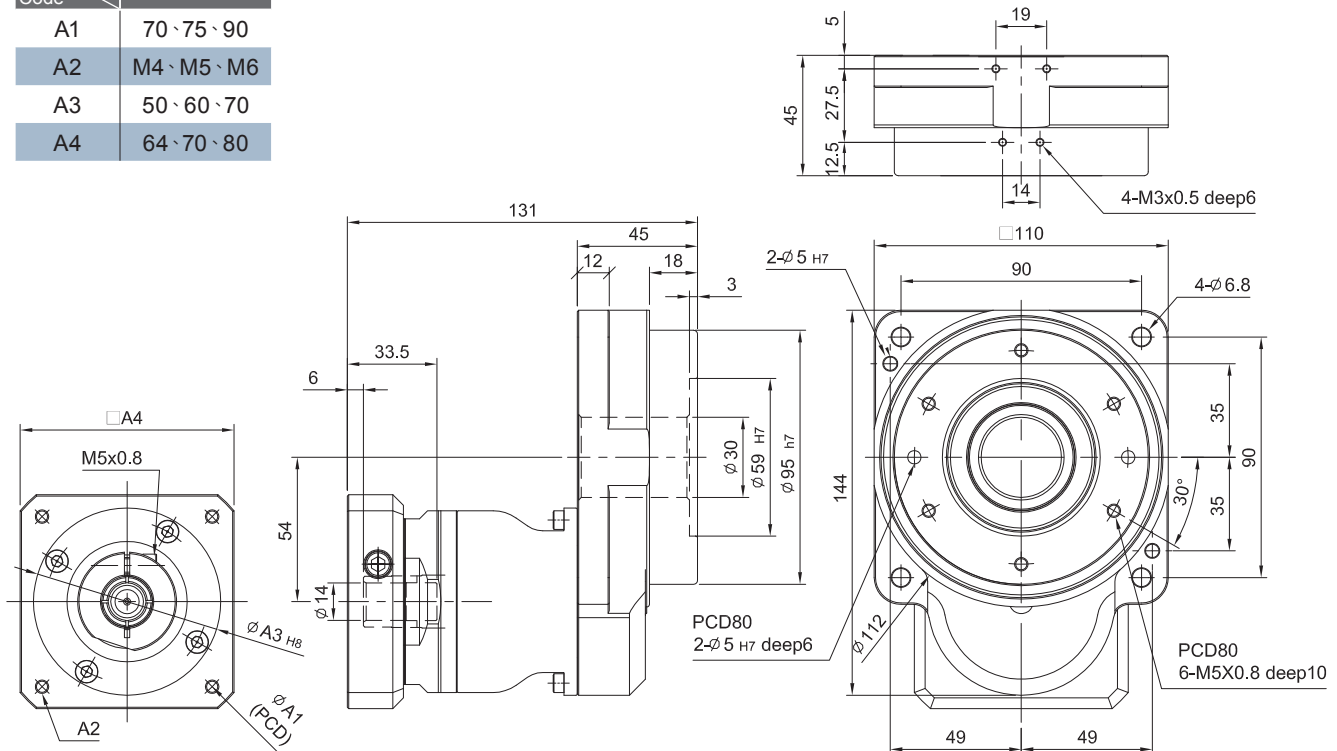

特性 Characteristic	代號	單位 Unit	GT-110B
輸出平台支撐軸承 / Output Table Supporting Bearing			深溝滾珠軸承 Ball Bearing
額定輸出扭矩 / Rated Output Torque		N.m	33
最大輸出扭矩 / Max. Output Torque 急停扭矩 / Emergency Stop Torque	T_{2NOT}	N.m	2 倍額定輸出扭矩 2 Time of Rated Output Torque
慣性慣量 / Inertia Moment		kg.m ²	$1,562 \times 10^{-6}$
出力容許轉速 / Output Permissible Speed		rpm	300
回程間隙 / Torsional Backlash		arcmin	≤ 1
動態齒隙差 / Lost Motion		arcmin	2 (0.033°)
重覆定位精度 / Repetitive Positioning Accuracy		arcsec	±10 (0.0028°)
容許載重 / Permissible Thrust Load		N	800
容許慣量載重 / Permissible Moment Load		N.m	16
工作台面偏擺 / Runout of Output Table Surface		mm	0.015
工作台同心度 / Runout of Output Table Inner / Outer Diameter		mm	0.015
工作台平行度 / Parallelism of Output Table		mm	0.025
使用壽命 / Service Life	L_H	hr	S5 周期運轉 : >20,000 (S1 連續運轉 : >10,000 hrs) S5 Cycle Operation : >20,000 (S1 Continuous peration : >10,000 hrs)
防護等級 / Protection Class			IP 65
重量 / Weight		Kg	3.76

MODEL : GT-135B

RATIO : 5.10.18 (單段 1-Stage)

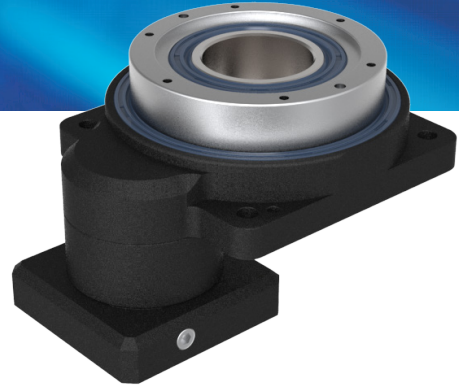

Unit: mm

Model Code	135
A1	70 · 75 · 90
A2	M4 · M5 · M6
A3	50 · 60 · 70
A4	64 · 70 · 80

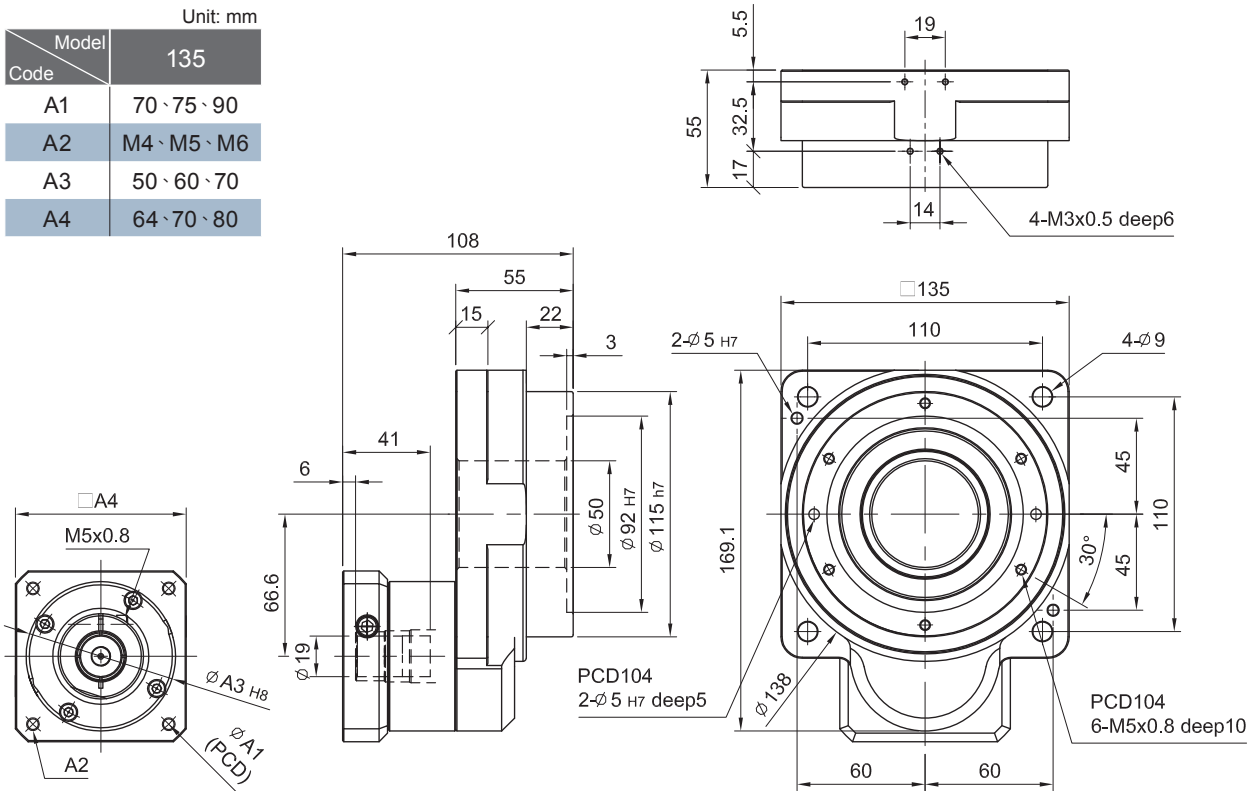

特性 Characteristic	代號	單位 Unit	GT-135B
輸出平台支撐軸承 / Output Table Supporting Bearing			深溝滾珠軸承 Ball Bearing
額定輸出扭矩 / Rated Output Torque		N.m	43
最大輸出扭矩 / Max. Output Torque 急停扭矩 / Emergency Stop Torque	T_{2NOT}	N.m	2 倍額定輸出扭矩 2 Time of Rated Output Torque
慣性慣量 / Inertia Moment		kg.m ²	$2,918 \times 10^{-6}$
出力容許轉速 / Output Permissible Speed		rpm	300
回程間隙 / Torsional Backlash		arcmin	≤ 1
動態齒隙差 / Lost Motion		arcmin	2 (0.033°)
重覆定位精度 / Repetitive Positioning Accuracy		arcsec	± 10 (0.0028°)
容許載重 / Permissible Thrust Load		N	1,450
容許慣量載重 / Permissible Moment Load		N.m	30
工作台面偏擺 / Runout of Output Table Surface		mm	0.015
工作合同心度 / Runout of Output Table Inner / Outer Diameter		mm	0.015
工作平台平行度 / Parallelism of Output Table		mm	0.025
使用壽命 / Service Life	L_H	hr	S5 周期運轉 : >20,000 (S1 連續運轉 : >10,000 hrs) S5 Cycle Operation : >20,000 (S1 Continuous peration : >10,000 hrs)
防護等級 / Protection Class			IP 65
重量 / Weight		Kg	3.83

MODEL : GT-200B

RATIO : 5.10.18 (單段 1-Stage)

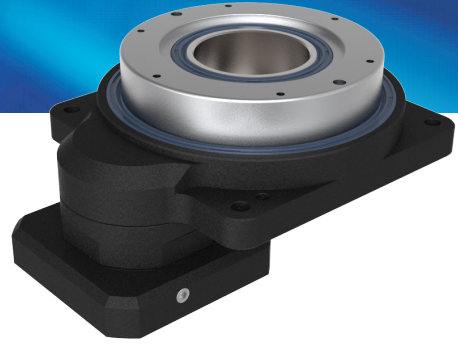

Unit: mm

Model Code	200
A1	90 · 100 · 115 · 145
A2	M5 · M6 · M8
A3	70 · 80 · 95 · 110
A4	92 · 110 · 130
A5	19 · 24
A6	44.5 · 57.5
A7	8.5 · 7.5
A8	125.5 · 138.5

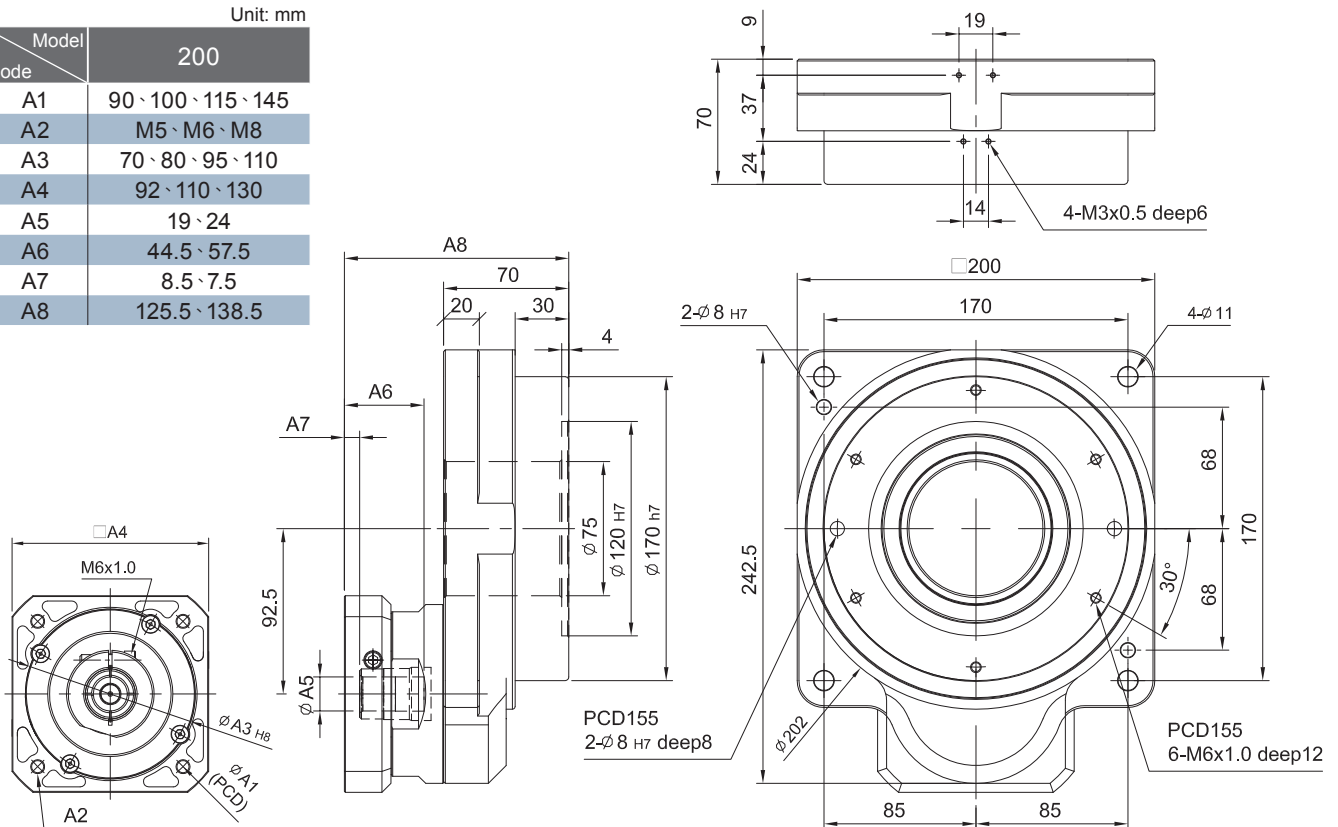

特性 Characteristic	代號	單位 Unit	GT-200B
輸出平台支撐軸承 / Output Table Supporting Bearing			深溝滾珠軸承 Ball Bearing
額定輸出扭矩 / Rated Output Torque		N.m	142
最大輸出扭矩 / Max. Output Torque 急停扭矩 / Emergency Stop Torque	T_{2NOT}	N.m	2 倍額定輸出扭矩 2 Time of Rated Output Torque
慣性慣量 / Inertia Moment		kg.m ²	29,072 x 10 ⁻⁶
出力容許轉速 / Output Permissible Speed		rpm	300
回程間隙 / Torsional Backlash		arcmin	≤ 1
動態齒隙差 / Lost Motion		arcmin	2 (0.033°)
重覆定位精度 / Repetitive Positioning Accuracy		arcsec	±10 (0.0028°)
容許載重 / Permissible Thrust Load		N	2,500
容許慣量載重 / Permissible Moment Load		N.m	50
工作台面偏擺 / Runout of Output Table Surface		mm	0.02
工作同心度 / Runout of Output Table Inner / Outer Diameter		mm	0.02
工作台平行度 / Parallelism of Output Table		mm	0.03
使用壽命 / Service Life	L_H	hr	S5 周期運轉 : >20,000 (S1 連續運轉 : >10,000 hrs) S5 Cycle Operation : >20,000 (S1 Continuous peration : >10,000 hrs)
防護等級 / Protection Class			IP 65
重量 / Weight		Kg	10.09

MODEL : GT-200B

RATIO : 25.50.100 (雙段 2-Stage)

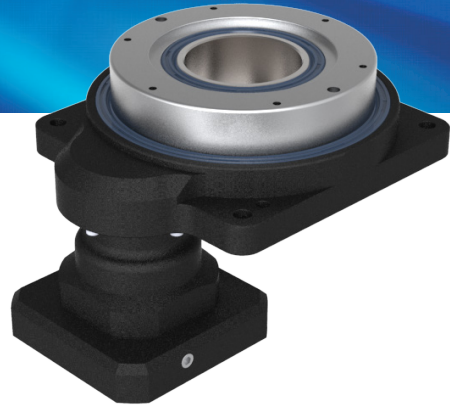

Unit: mm

Model Code	200
A1	90 · 100 · 115 · 145
A2	M5 · M6 · M8
A3	70 · 80 · 95 · 110
A4	92 · 110 · 130

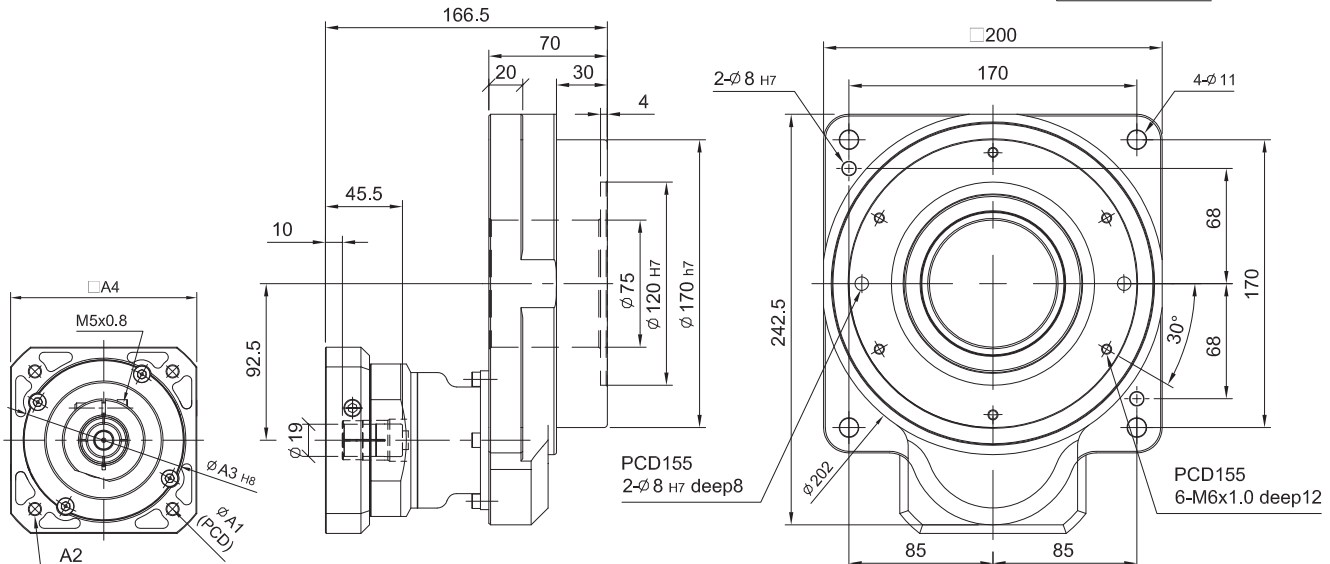
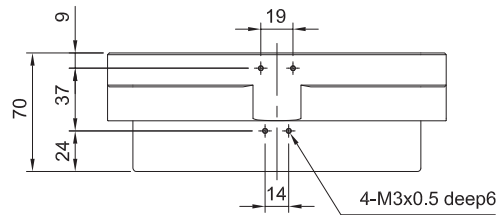

特性 Characteristic	代號	單位 Unit	GT-200B
輸出平台支撐軸承 / Output Table Supporting Bearing			深溝滾珠軸承 Ball Bearing
額定輸出扭矩 / Rated Output Torque		N.m	142
最大輸出扭矩 / Max. Output Torque 急停扭矩 / Emergency Stop Torque	T_{2NOT}	N.m	2 倍額定輸出扭矩 2 Time of Rated Output Torque
慣性慣量 / Inertia Moment		kg.m ²	29,072 x 10 ⁻⁶
出力容許轉速 / Output Permissible Speed		rpm	300
回程間隙 / Torsional Backlash		arcmin	≤ 1
動態齒隙差 / Lost Motion		arcmin	2 (0.033°)
重覆定位精度 / Repetitive Positioning Accuracy		arcsec	±10 (0.0028°)
容許載重 / Permissible Thrust Load		N	2,500
容許慣量載重 / Permissible Moment Load		N.m	50
工作台面偏擺 / Runout of Output Table Surface		mm	0.02
工作台同心度 / Runout of Output Table Inner / Outer Diameter		mm	0.02
工作台平行度 / Parallelism of Output Table		mm	0.03
使用壽命 / Service Life	L_H	hr	S5 周期運轉 : >20,000 (S1 連續運轉 : >10,000 hrs) S5 Cycle Operation : >20,000 (S1 Continuous peration : >10,000 hrs)
防護等級 / Protection Class			IP 65
重量 / Weight		Kg	11.8

MODEL : GT-60C

RATIO : 5.10.18 (單段 1-Stage)

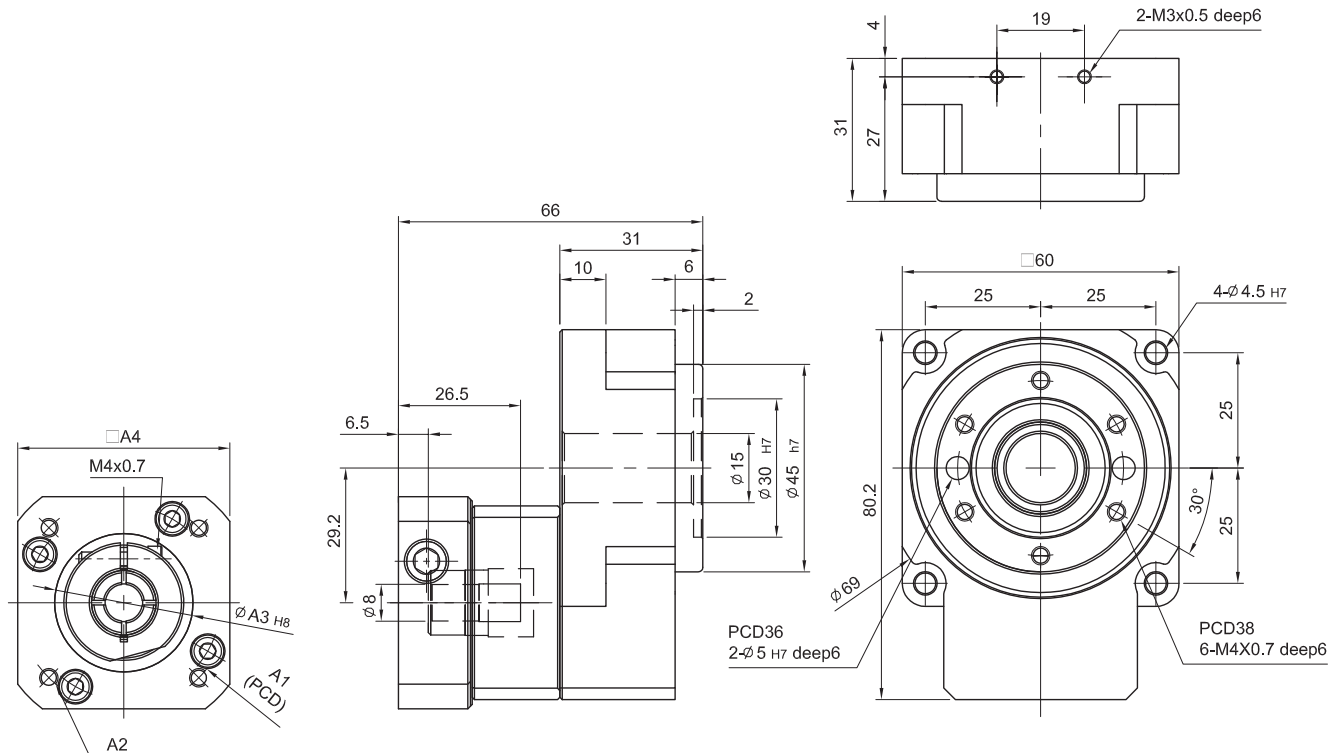
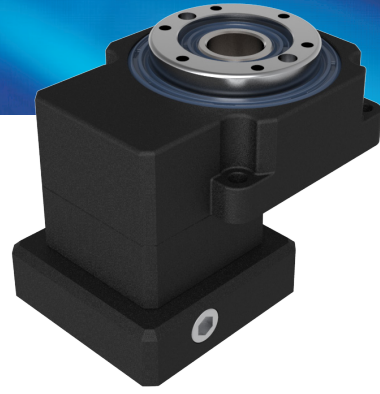

特性 Characteristic	代號	單位 Unit	GT-60C
輸出平台支撐軸承 / Output Table Supporting Bearing			交叉斜角滾柱軸承 Crossed Roller Bearing
額定輸出扭矩 / Rated Output Torque		N.m	5
最大輸出扭矩 / Max. Output Torque 急停扭矩 / Emergency Stop Torque	T_{2NOT}	N.m	2 倍額定輸出扭矩 2 Time of Rated Output Torque
慣性慣量 / Inertia Moment		kg.m ²	735×10^{-7}
出力容許轉速 / Output Permissible Speed		rpm	200
回程間隙 / Torsional Backlash		arcmin	≤ 1
動態齒隙差 / Lost Motion		arcmin	2 (0.033°)
重覆定位精度 / Repetitive Positioning Accuracy		arcsec	± 10 (0.0028°)
容許載重 / Permissible Thrust Load		N	500
容許慣量載重 / Permissible Moment Load		N.m	10
工作台面偏擺 / Runout of Output Table Surface		mm	0.01
工作同心度 / Runout of Output Table Inner / Outer Diameter		mm	0.01
工作平行度 / Parallelism of Output Table		mm	0.02
使用壽命 / Service Life	L_H	hr	S5 周期運轉 : >20,000 (S1 連續運轉 : >10,000 hrs) S5 Cycle Operation: >20,000 (S1 Continuous peration: >10,000 hrs)
防護等級 / Protection Class			IP 65
重量 / Weight		Kg	0.62

MODEL : GT-60C

RATIO : 25.50.100 (雙段 2-Stage)

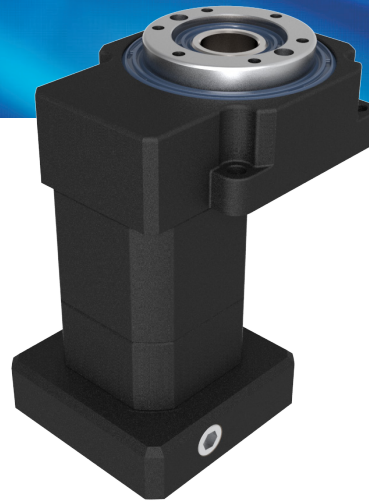

GT

Unit: mm

Model Code	60
A1	46 · 63 · 60
A2	M3 · M4 · M5
A3	30 · 40 · 50
A4	46 · 55

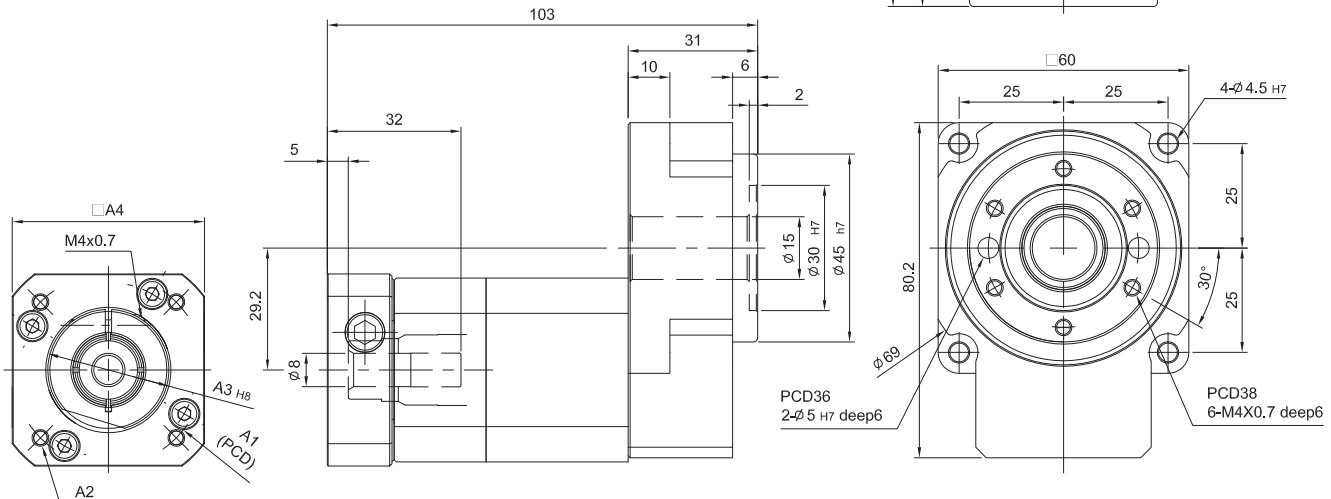

特性 Characteristic	代號	單位 Unit	GT-60C
輸出平台支撐軸承 / Output Table Supporting Bearing			交叉斜角滾柱軸承 Crossed Roller Bearing
額定輸出扭矩 / Rated Output Torque		N.m	5
最大輸出扭矩 / Max. Output Torque 急停扭矩 / Emergency Stop Torque	T_{2NOT}	N.m	2 倍額定輸出扭矩 2 Time of Rated Output Torque
慣性慣量 / Inertia Moment		kg.m ²	735×10^{-7}
出力容許轉速 / Output Permissible Speed		rpm	200
回程間隙 / Torsional Backlash		arcmin	≤ 1
動態齒隙差 / Lost Motion		arcmin	2 (0.033°)
重覆定位精度 / Repetitive Positioning Accuracy		arcsec	±10 (0.0028°)
容許載重 / Permissible Thrust Load		N	500
容許慣量載重 / Permissible Moment Load		N.m	10
工作台面偏擺 / Runout of Output Table Surface		mm	0.01
工作台同心度 / Runout of Output Table Inner / Outer Diameter		mm	0.01
工作台平行度 / Parallelism of Output Table		mm	0.02
使用壽命 / Service Life	L_H	hr	S5 周期運轉 : >20,000 (S1 連續運轉 : >10,000 hrs) S5 Cycle Operation : >20,000 (S1 Continuous peration : >10,000 hrs)
防護等級 / Protection Class			IP 65
重量 / Weight		Kg	1.1

MODEL : GT-85C

RATIO : 5.10.18 (單段 1-Stage)

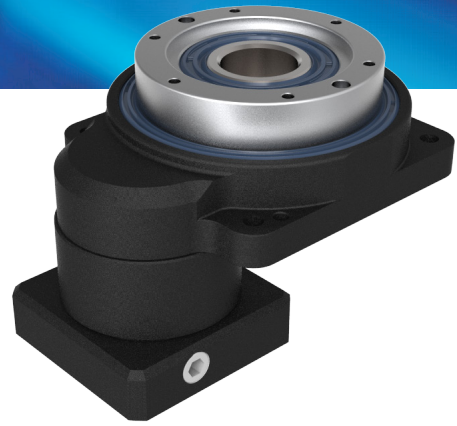

Unit: mm

Model Code	85
A1	46 · 63 · 60
A2	M3 · M4 · M5
A3	30 · 40 · 50
A4	46 · 55

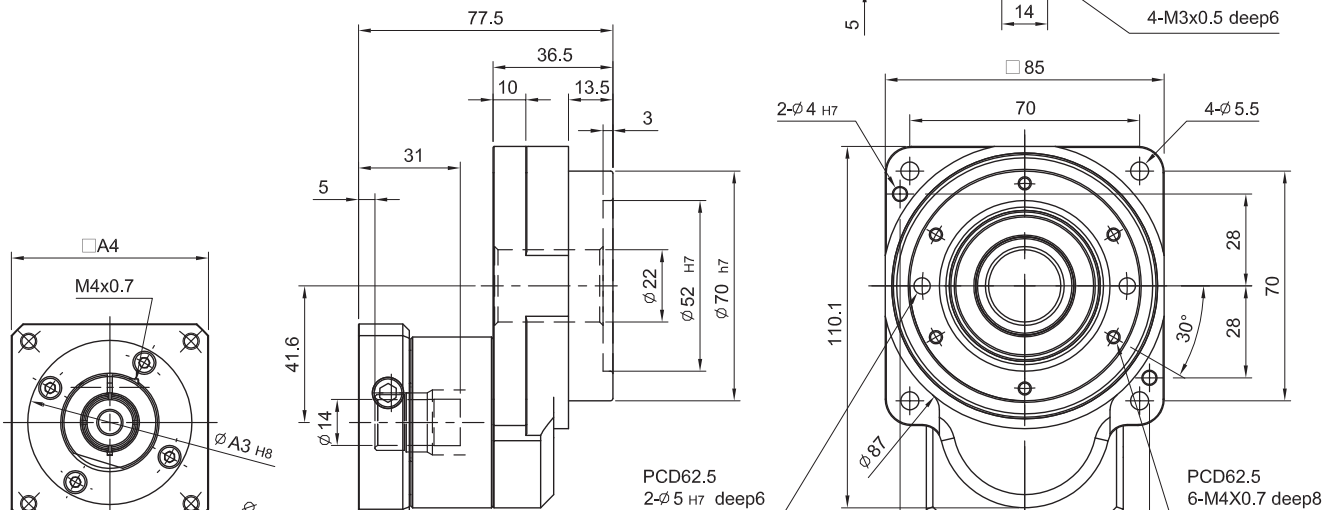

特性 Characteristic	代號	單位 Unit	GT-85C
輸出平台支撐軸承 / Output Table Supporting Bearing			交叉斜角滾柱軸承 Crossed Roller Bearing
額定輸出扭矩 / Rated Output Torque		N.m	18
最大輸出扭矩 / Max. Output Torque 急停扭矩 / Emergency Stop Torque	T_{2NOT}	N.m	2 倍額定輸出扭矩 2 Time of Rated Output Torque
慣性慣量 / Inertia Moment		kg.m ²	1,203 x 10 ⁻⁶
出力容許轉速 / Output Permissible Speed		rpm	200
回程間隙 / Torsional Backlash		arcmin	≤ 1
動態齒隙差 / Lost Motion		arcmin	2 (0.033°)
重覆定位精度 / Repetitive Positioning Accuracy		arcsec	±10 (0.0028°)
容許載重 / Permissible Thrust Load		N	900
容許慣量載重 / Permissible Moment Load		N.m	18
工作台面偏擺 / Runout of Output Table Surface		mm	0.01
工作合同心度 / Runout of Output Table Inner / Outer Diameter		mm	0.01
工作平台平行度 / Parallelism of Output Table		mm	0.02
使用壽命 / Service Life	L_H	hr	S5 周期運轉 : >20,000 (S1 連續運轉 : >10,000 hrs) S5 Cycle Operation: >20,000 (S1 Continuous peration: >10,000 hrs)
防護等級 / Protection Class			IP 65
重量 / Weight		Kg	1.1

MODEL : GT-85C

RATIO : 25.50.100 (雙段 2-Stage)

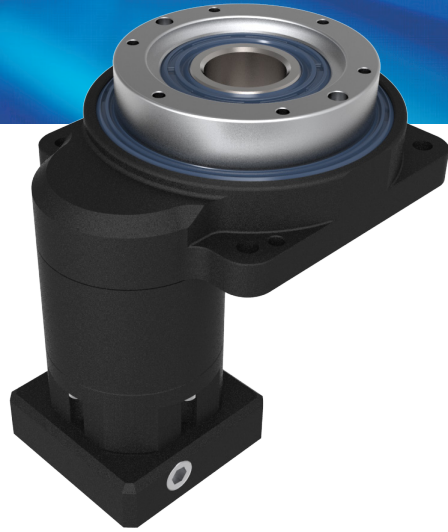

Unit: mm

Model Code	85
A1	46 · 63 · 60
A2	M3 · M4 · M5
A3	30 · 40 · 50
A4	46 · 55

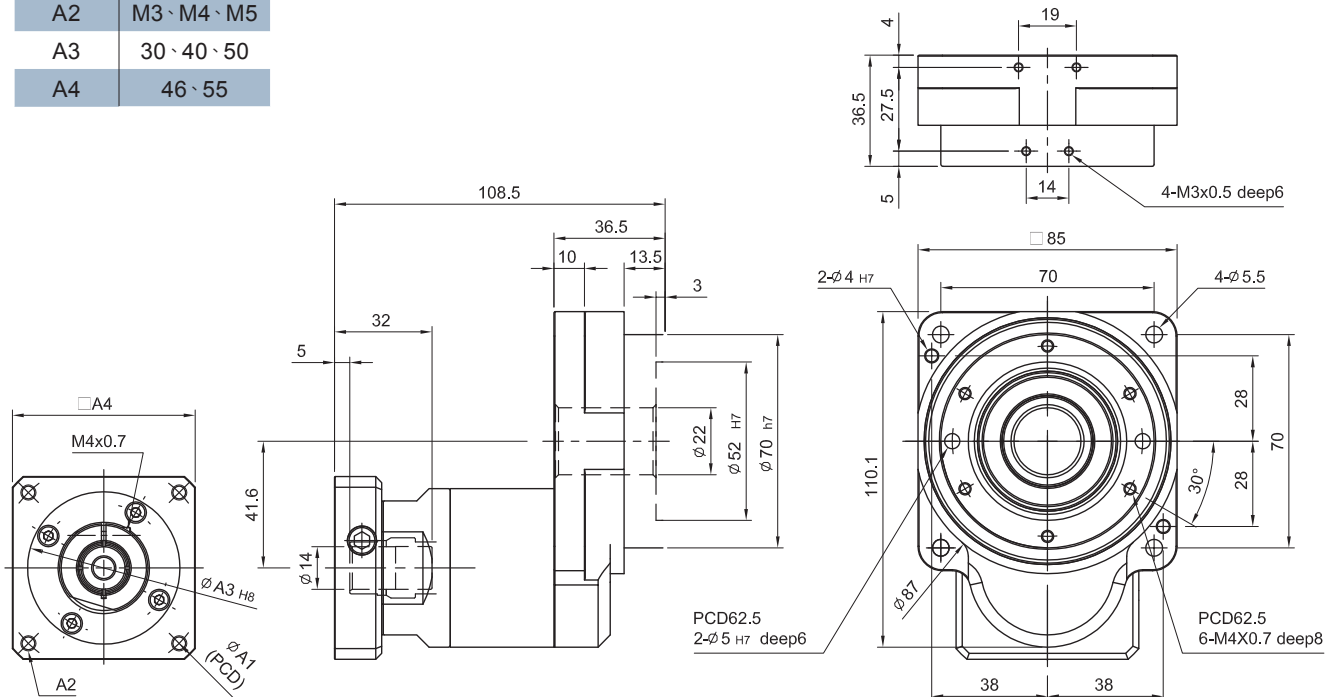

特性 Characteristic	代號	單位 Unit	GT-85C
輸出平台支撐軸承 / Output Table Supporting Bearing			交叉斜角滾柱軸承 Crossed Roller Bearing
額定輸出扭矩 / Rated Output Torque		N.m	18
最大輸出扭矩 / Max. Output Torque 急停扭矩 / Emergency Stop Torque	T_{2NOT}	N.m	2 倍額定輸出扭矩 2 Time of Rated Output Torque
慣性慣量 / Inertia Moment		kg.m ²	$1,203 \times 10^{-6}$
出力容許轉速 / Output Permissible Speed		rpm	200
回程間隙 / Torsional Backlash		arcmin	≤ 1
動態齒隙差 / Lost Motion		arcmin	2 (0.033°)
重覆定位精度 / Repetitive Positioning Accuracy		arcsec	± 10 (0.0028°)
容許載重 / Permissible Thrust Load		N	900
容許慣量載重 / Permissible Moment Load		N.m	18
工作台面偏擺 / Runout of Output Table Surface		mm	0.01
工作台同心度 / Runout of Output Table Inner / Outer Diameter		mm	0.01
工作台平行度 / Parallelism of Output Table		mm	0.02
使用壽命 / Service Life	L_H	hr	S5 周期運轉 : >20,000 (S1 連續運轉 : >10,000 hrs) S5 Cycle Operation : >20,000 (S1 Continuous peration : >10,000 hrs)
防護等級 / Protection Class			IP 65
重量 / Weight		Kg	1.78

MODEL : GT-110C

RATIO : 5.10.18 (單段 1-Stage)

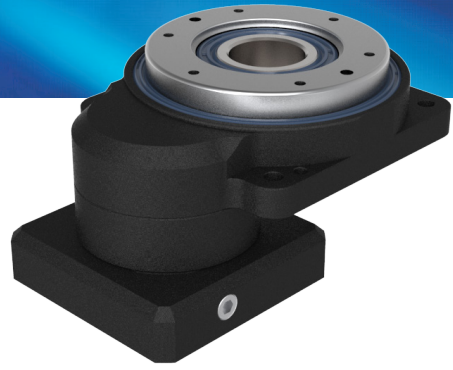

Unit: mm

Model Code	110
A1	70 · 75 · 90
A2	M4 · M5 · M6
A3	50 · 60 · 70
A4	64 · 70 · 80

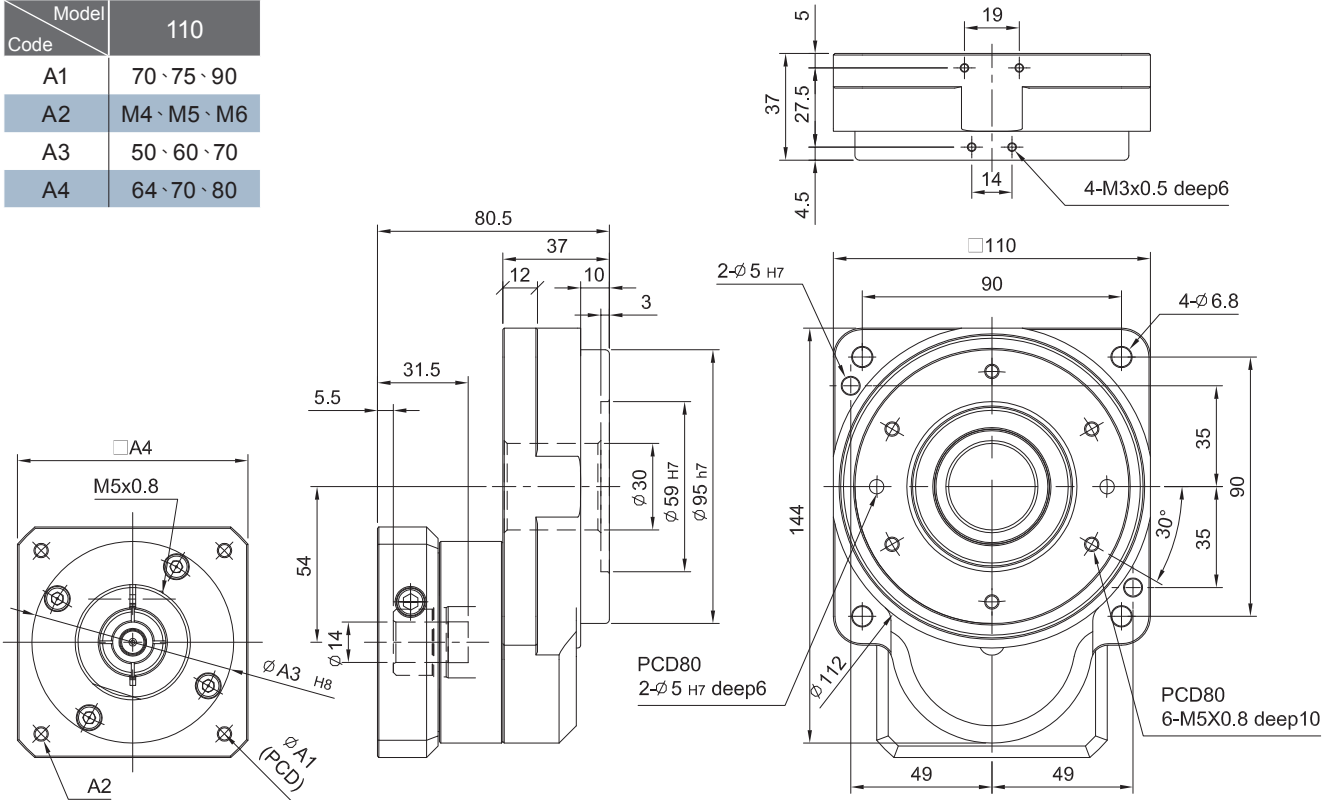

特性 Characteristic	代號	單位 Unit	GT-110C
輸出平台支撐軸承 / Output Table Supporting Bearing			交叉斜角滾柱軸承 Crossed Roller Bearing
額定輸出扭矩 / Rated Output Torque		N.m	33
最大輸出扭矩 / Max. Output Torque 急停扭矩 / Emergency Stop Torque	T_{2NOT}	N.m	2 倍額定輸出扭矩 2 Time of Rated Output Torque
慣性慣量 / Inertia Moment		kg.m ²	1,483 x 10 ⁻⁶
出力容許轉速 / Output Permissible Speed		rpm	200
回程間隙 / Torsional Backlash		arcmin	≤ 1
動態齒隙差 / Lost Motion		arcmin	2 (0.033°)
重覆定位精度 / Repetitive Positioning Accuracy		arcsec	±10 (0.0028°)
容許載重 / Permissible Thrust Load		N	1,200
容許慣量載重 / Permissible Moment Load		N.m	24
工作台面偏擺 / Runout of Output Table Surface		mm	0.015
工作合同心度 / Runout of Output Table Inner / Outer Diameter		mm	0.015
工作平台平行度 / Parallelism of Output Table		mm	0.025
使用壽命 / Service Life	L_H	hr	S5 周期運轉 : >20,000 (S1 連續運轉 : >10,000 hrs) S5 Cycle Operation : >20,000 (S1 Continuous peration : >10,000 hrs)
防護等級 / Protection Class			IP 65
重量 / Weight		Kg	2.04

MODEL : GT-110C

RATIO : 25.50.100 (雙段 2-Stage)



GT

Unit: mm

Model Code	110
A1	70 · 75 · 90
A2	M4 · M5 · M6
A3	50 · 60 · 70
A4	64 · 70 · 80

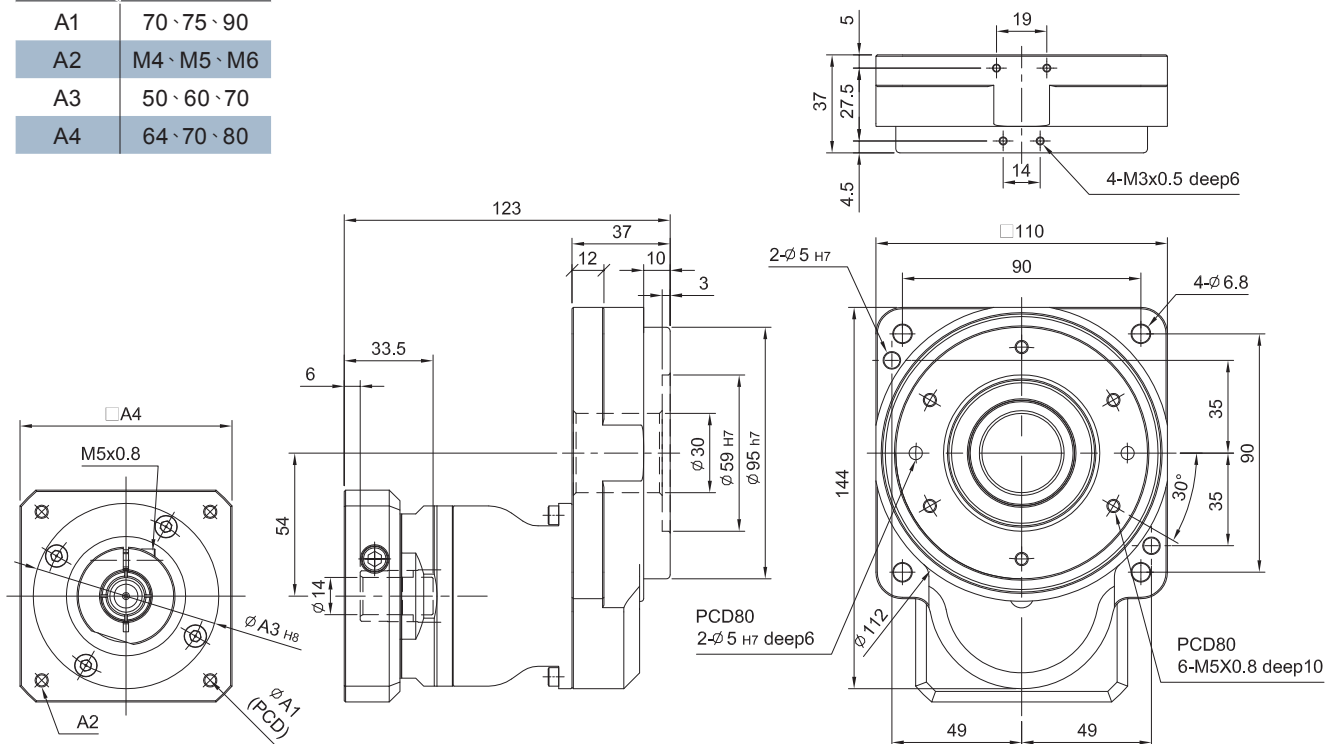

特性 Characteristic	代號	單位 Unit	GT-110C
輸出平台支撐軸承 / Output Table Supporting Bearing			交叉斜角滾柱軸承 Crossed Roller Bearing
額定輸出扭矩 / Rated Output Torque		N.m	33
最大輸出扭矩 / Max. Output Torque 急停扭矩 / Emergency Stop Torque	T_{2NOT}	N.m	2 倍額定輸出扭矩 2 Time of Rated Output Torque
慣性慣量 / Inertia Moment		kg.m ²	$1,483 \times 10^{-6}$
出力容許轉速 / Output Permissible Speed		rpm	200
回程間隙 / Torsional Backlash		arcmin	≤ 1
動態齒隙差 / Lost Motion		arcmin	2 (0.033°)
重覆定位精度 / Repetitive Positioning Accuracy		arcsec	±10 (0.0028°)
容許載重 / Permissible Thrust Load		N	1,200
容許慣量載重 / Permissible Moment Load		N.m	24
工作台面偏擺 / Runout of Output Table Surface		mm	0.015
工作台同心度 / Runout of Output Table Inner / Outer Diameter		mm	0.015
工作台平行度 / Parallelism of Output Table		mm	0.025
使用壽命 / Service Life	L_H	hr	S5 周期運轉 : >20,000 (S1 連續運轉 : >10,000 hrs) S5 Cycle Operation : >20,000 (S1 Continuous peration : >10,000 hrs)
防護等級 / Protection Class			IP 65
重量 / Weight		Kg	3.51

MODEL : GT-135C

RATIO : 5.10.18 (單段 1-Stage)

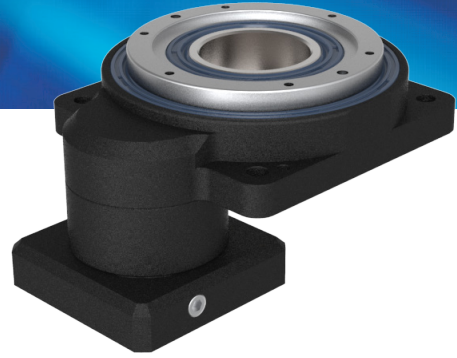

Unit: mm

Model Code	135
A1	70 · 75 · 90
A2	M4 · M5 · M6
A3	50 · 60 · 70
A4	64 · 70 · 80

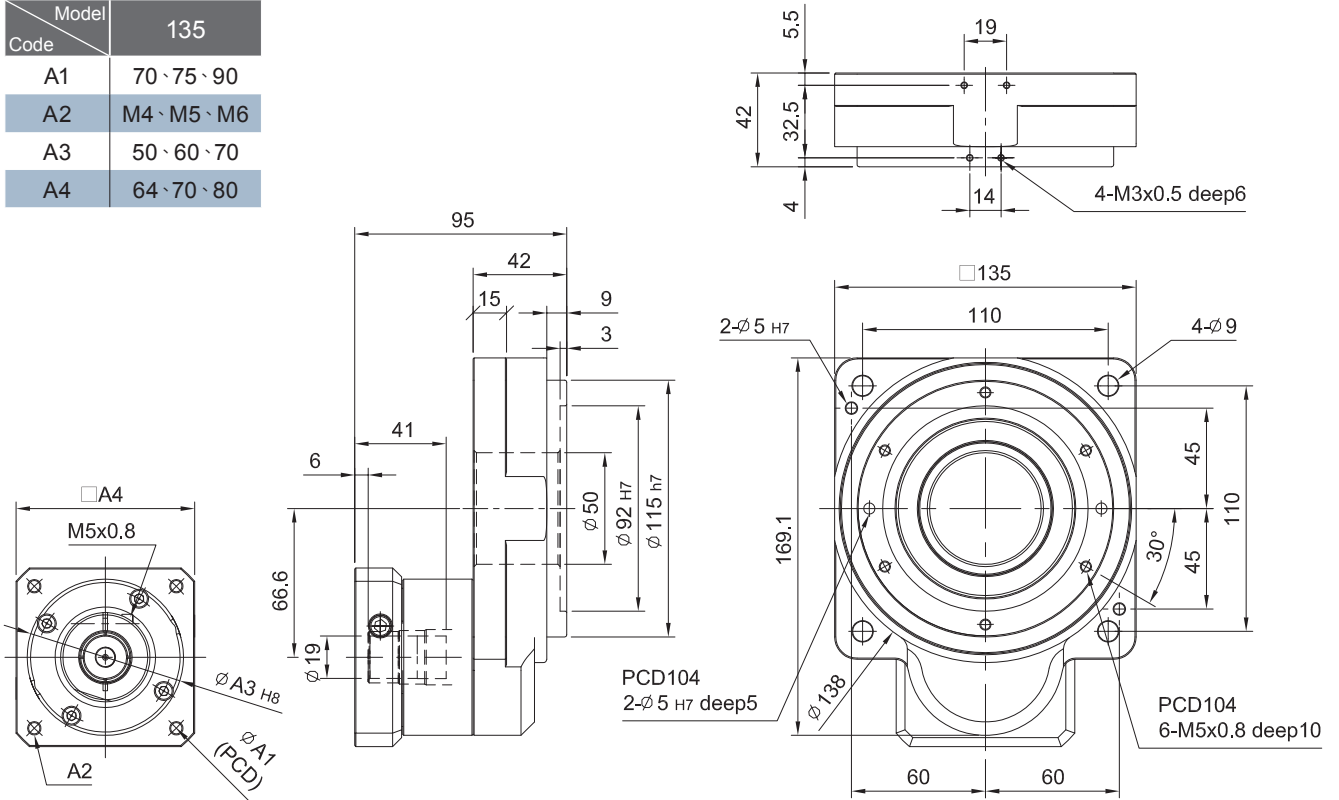

特性 Characteristic	代號	單位 Unit	GT-135C
輸出平台支撐軸承 / Output Table Supporting Bearing			交叉斜角滾柱軸承 Crossed Roller Bearing
額定輸出扭矩 / Rated Output Torque		N.m	43
最大輸出扭矩 / Max. Output Torque 急停扭矩 / Emergency Stop Torque	T_{2NOT}	N.m	2 倍額定輸出扭矩 2 Time of Rated Output Torque
慣性慣量 / Inertia Moment		kg.m ²	$2,772 \times 10^{-6}$
出力容許轉速 / Output Permissible Speed		rpm	200
回程間隙 / Torsional Backlash		arcmin	≤ 1
動態齒隙差 / Lost Motion		arcmin	2 (0.033°)
重覆定位精度 / Repetitive Positioning Accuracy		arcsec	± 10 (0.0028°)
容許載重 / Permissible Thrust Load		N	2,200
容許慣量載重 / Permissible Moment Load		N.m	45
工作台面偏擺 / Runout of Output Table Surface		mm	0.015
工作同心度 / Runout of Output Table Inner / Outer Diameter		mm	0.015
工作台平行度 / Parallelism of Output Table		mm	0.025
使用壽命 / Service Life	L_H	hr	S5 周期運轉 : >20,000 (S1 連續運轉 : >10,000 hrs) S5 Cycle Operation : >20,000 (S1 Continuous peration : >10,000 hrs)
防護等級 / Protection Class			IP 65
重量 / Weight		Kg	3.13

MODEL : GT-135C

RATIO : 25.50.100 (雙段 2-Stage)

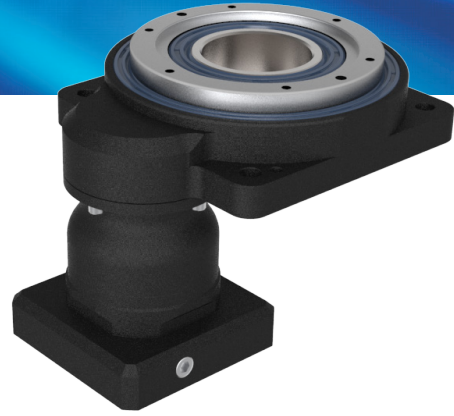

GT

Unit: mm

Model Code	135
A1	70 · 75 · 90
A2	M4 · M5 · M6
A3	50 · 60 · 70
A4	64 · 70 · 80

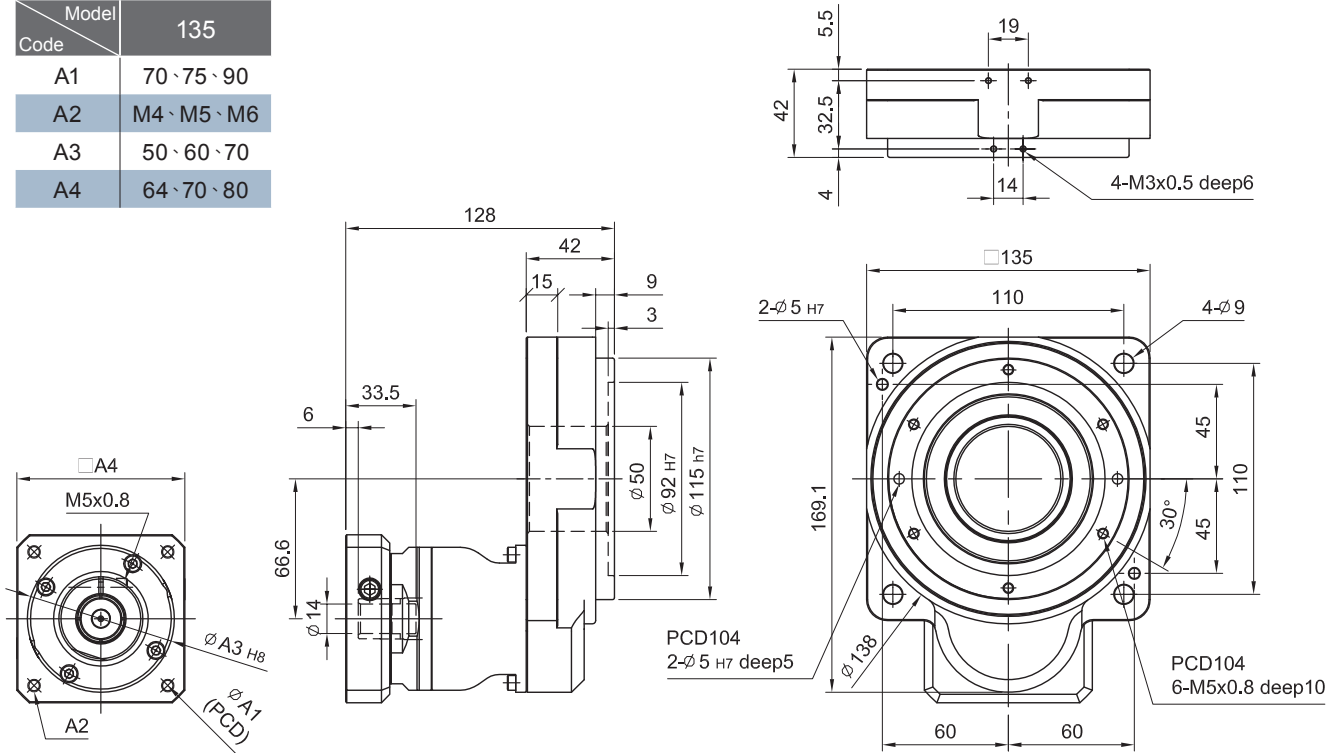

特性 Characteristic	代號	單位 Unit	GT-135C
輸出平台支撐軸承 / Output Table Supporting Bearing			交叉斜角滾柱軸承 Crossed Roller Bearing
額定輸出扭矩 / Rated Output Torque		N.m	43
最大輸出扭矩 / Max. Output Torque 急停扭矩 / Emergency Stop Torque	T_{2NOT}	N.m	2 倍額定輸出扭矩 2 Time of Rated Output Torque
慣性慣量 / Inertia Moment		kg.m ²	$2,772 \times 10^{-6}$
出力容許轉速 / Output Permissible Speed		rpm	200
回程間隙 / Torsional Backlash		arcmin	≤ 1
動態齒隙差 / Lost Motion		arcmin	2 (0.033°)
重覆定位精度 / Repetitive Positioning Accuracy		arcsec	± 10 (0.0028°)
容許載重 / Permissible Thrust Load		N	2,200
容許慣量載重 / Permissible Moment Load		N.m	45
工作台面偏擺 / Runout of Output Table Surface		mm	0.015
工作台同心度 / Runout of Output Table Inner / Outer Diameter		mm	0.015
工作台平行度 / Parallelism of Output Table		mm	0.025
使用壽命 / Service Life	L_H	hr	S5 周期運轉 : >20,000 (S1 連續運轉 : >10,000 hrs) S5 Cycle Operation : >20,000 (S1 Continuous peration : >10,000 hrs)
防護等級 / Protection Class			IP 65
重量 / Weight		Kg	4.21

MODEL : GT-200C

RATIO : 5.10.18 (單段 1-Stage)

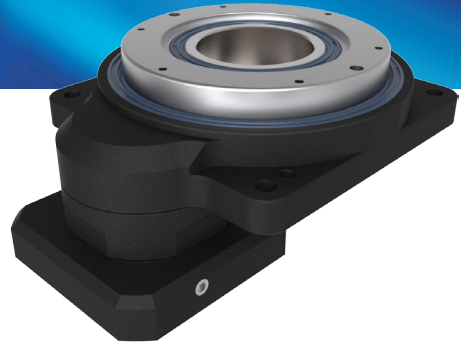

Unit: mm

Model Code	200
A1	90 · 100 · 115 · 145
A2	M5 · M6 · M8
A3	70 · 80 · 95 · 110
A4	92 · 110 · 130
A5	19 · 24
A6	44.5 · 57.5
A7	8.5 · 7.5
A8	113.5 · 126.5

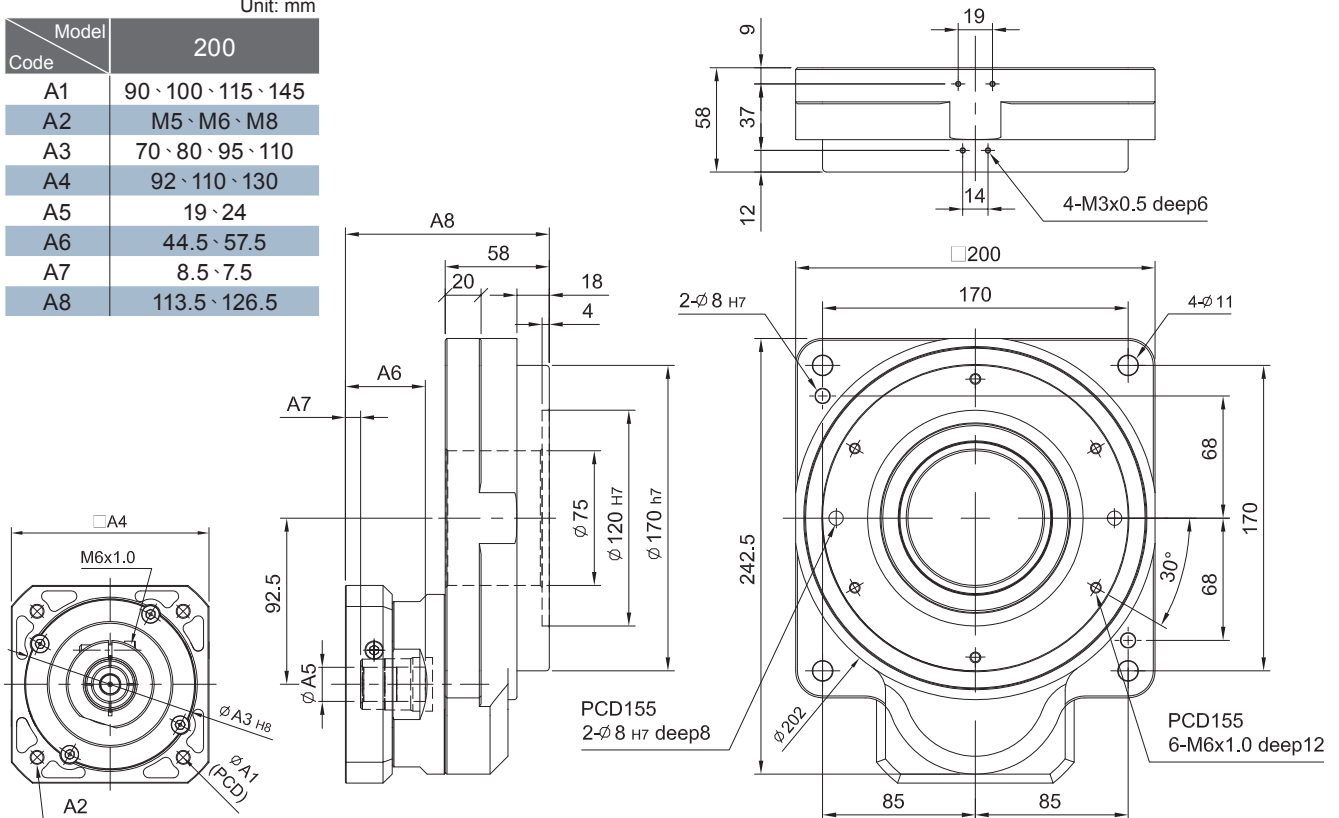

特性 Characteristic	代號	單位 Unit	GT-200C
輸出平台支撐軸承 / Output Table Supporting Bearing			交叉斜角滾柱軸承 Crossed Roller Bearing
額定輸出扭矩 / Rated Output Torque		N.m	142
最大輸出扭矩 / Max. Output Torque 急停扭矩 / Emergency Stop Torque	T_{2NOT}	N.m	2 倍額定輸出扭矩 2 Time of Rated Output Torque
慣性慣量 / Inertia Moment		kg.m ²	27,619 x 10 ⁻⁶
出力容許轉速 / Output Permissible Speed		rpm	200
回程間隙 / Torsional Backlash		arcmin	≤ 1
動態齒隙差 / Lost Motion		arcmin	2 (0.033°)
重覆定位精度 / Repetitive Positioning Accuracy		arcsec	±10 (0.0028°)
容許載重 / Permissible Thrust Load		N	4,000
容許慣量載重 / Permissible Moment Load		N.m	80
工作台面偏擺 / Runout of Output Table Surface		mm	0.02
工作合同心度 / Runout of Output Table Inner / Outer Diameter		mm	0.02
工作平台平行度 / Parallelism of Output Table		mm	0.03
使用壽命 / Service Life	L_H	hr	S5 周期運轉 : >20,000 (S1 連續運轉 : >10,000 hrs) S5 Cycle Operation : >20,000 (S1 Continuous peration : >10,000 hrs)
防護等級 / Protection Class			IP 65
重量 / Weight		Kg	8.66

MODEL : GT-200C

RATIO : 25.50.100 (雙段 2-Stage)

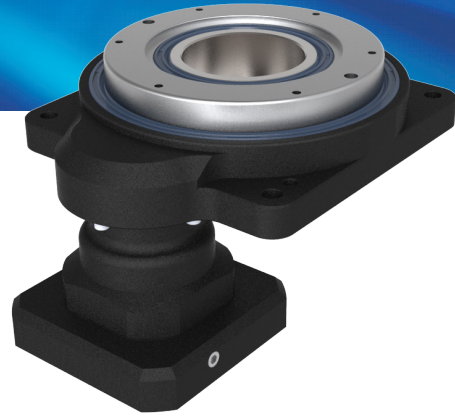

Unit: mm

Model Code	200
A1	90、100、115、145
A2	M5、M6、M8
A3	70、80、95、110
A4	92、110、130

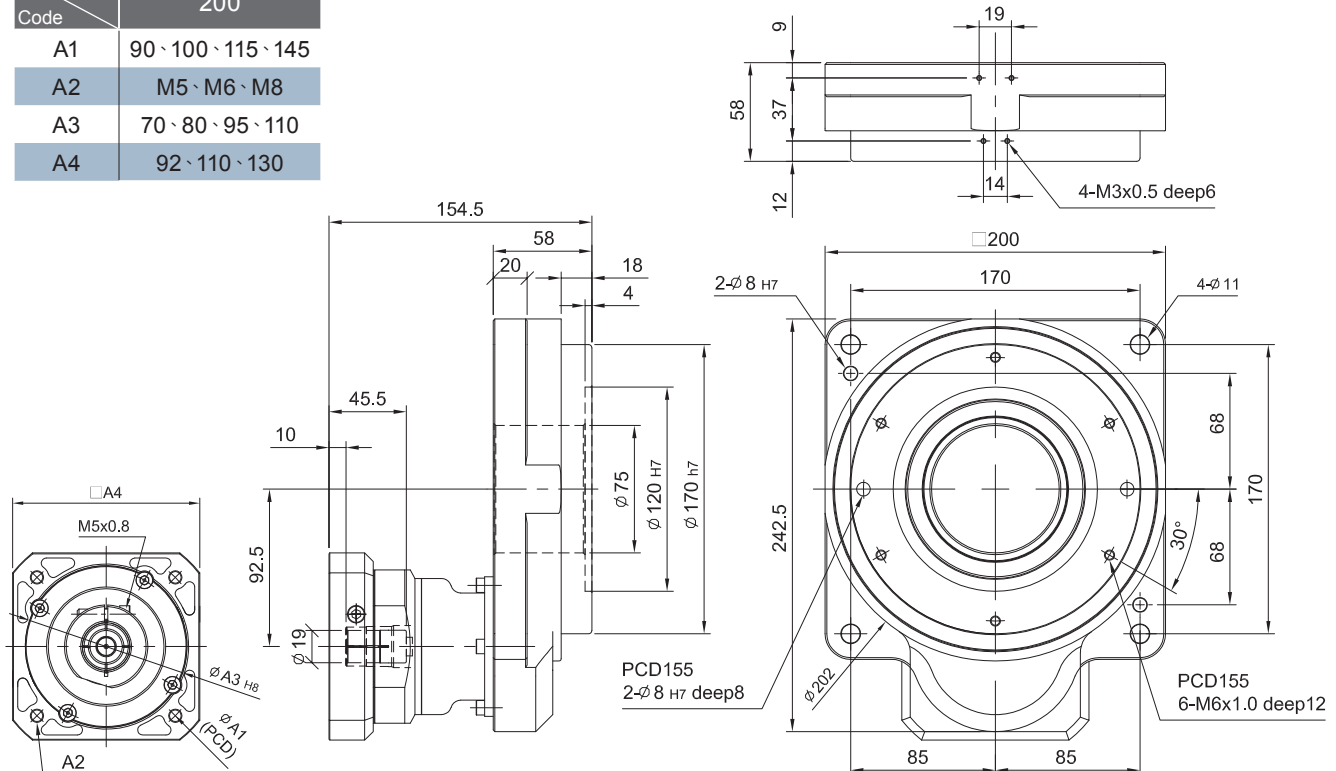

特性 Characteristic	代號	單位 Unit	GT-200C
輸出平台支撐軸承 / Output Table Supporting Bearing			交叉斜角滾柱軸承 Crossed Roller Bearing
額定輸出扭矩 / Rated Output Torque		N.m	142
最大輸出扭矩 / Max. Output Torque 急停扭矩 / Emergency Stop Torque	T_{2NOT}	N.m	2 倍額定輸出扭矩 2 Time of Rated Output Torque
慣性慣量 / Inertia Moment		kg.m ²	$27,619 \times 10^{-6}$
出力容許轉速 / Output Permissible Speed		rpm	200
回程間隙 / Torsional Backlash		arcmin	≤ 1
動態齒隙差 / Lost Motion		arcmin	2 (0.033°)
重覆定位精度 / Repetitive Positioning Accuracy		arcsec	± 10 (0.0028°)
容許載重 / Permissible Thrust Load		N	4,000
容許慣量載重 / Permissible Moment Load		N.m	80
工作台面偏擺 / Runout of Output Table Surface		mm	0.02
工作同心度 / Runout of Output Table Inner / Outer Diameter		mm	0.02
工作台面平行度 / Parallelism of Output Table		mm	0.03
使用壽命 / Service Life	L_H	hr	S5 周期運轉 : >20,000 (S1 連續運轉 : >10,000 hrs) S5 Cycle Operation : >20,000 (S1 Continuous peration : >10,000 hrs)
防護等級 / Protection Class			IP 65
重量 / Weight		Kg	10.3

MODEL : GT-60H

RATIO : 10.18 (單段 1-Stage)

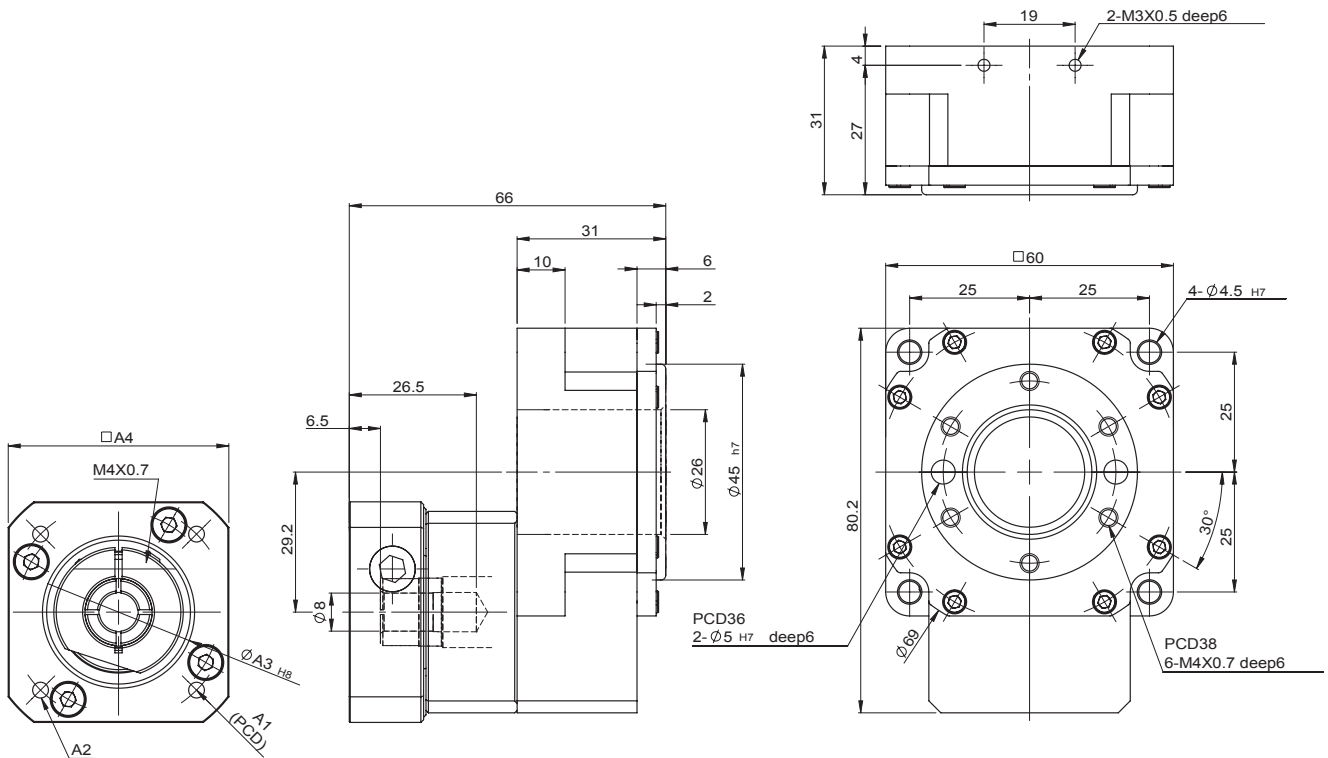
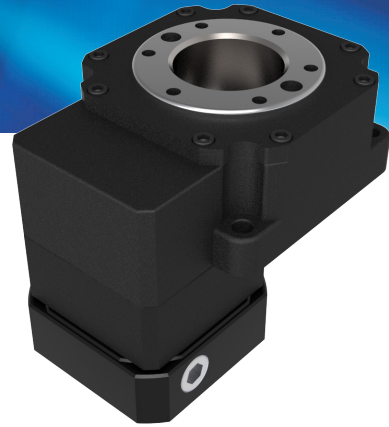

特性 Characteristic	代號	單位 Unit	GT-60H
輸出平台支撐軸承 / Output Table Supporting Bearing			深溝滾珠軸承大中空 Ball Bearing
額定輸出扭矩 / Rated Output Torque		N.m	5
最大輸出扭矩 / Max. Output Torque 急停扭矩 / Emergency Stop Torque	T_{2NOT}	N.m	2 倍額定輸出扭矩 2 Time of Rated Output Torque
慣性慣量 / Inertia Moment		kg.m ²	777×10^{-7}
出力容許轉速 / Output Permissible Speed		rpm	300
回程間隙 / Torsional Backlash		arcmin	≤ 1
動態齒隙差 / Lost Motion		arcmin	2 (0.033°)
重覆定位精度 / Repetitive Positioning Accuracy		arcsec	±10 (0.0028°)
容許載重 / Permissible Thrust Load		N	350
容許慣量載重 / Permissible Moment Load		N.m	7
工作台面偏擺 / Runout of Output Table Surface		mm	0.01
工作台同心度 / Runout of Output Table Inner / Outer Diameter		mm	0.01
工作台平行度 / Parallelism of Output Table		mm	0.02
防護等級 / Protection Class			IP 65
重量 / Weight		Kg	

MODEL : GT-60H

RATIO : 50.100 (雙段 2-Stage)

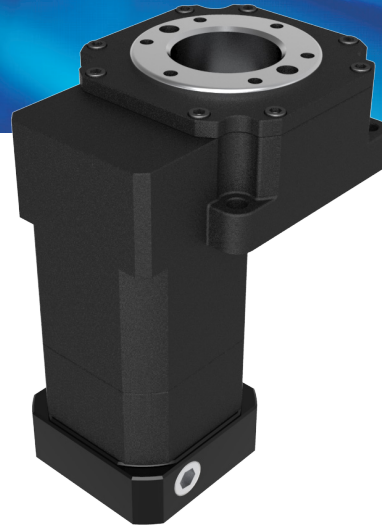

Unit: mm

Model Code	60
A1	46 · 63 · 60
A2	M3 · M4 · M5
A3	30 · 40 · 50
A4	46 · 55

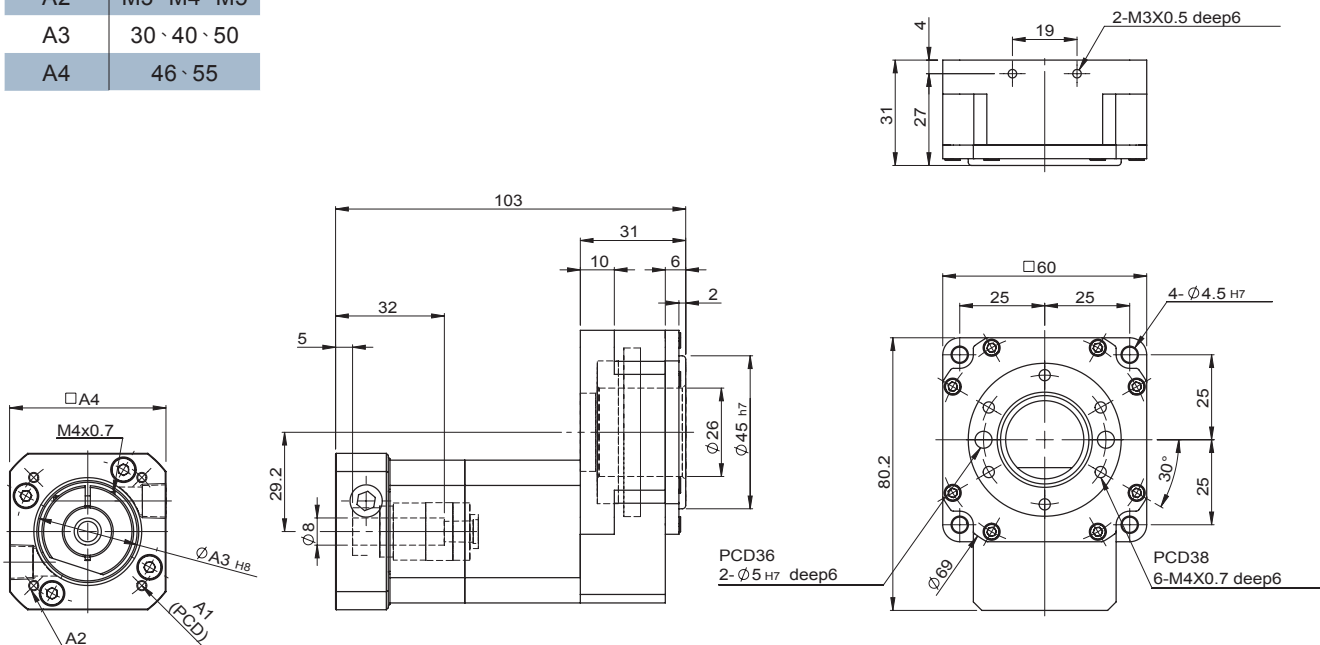

特性 Characteristic	代號	單位 Unit	GT-60H
輸出平台支撐軸承 / Output Table Supporting Bearing			深溝滾珠軸承大中空 Ball Bearing
額定輸出扭矩 / Rated Output Torque		N.m	5
最大輸出扭矩 / Max. Output Torque 急停扭矩 / Emergency Stop Torque	T_{2NOT}	N.m	2 倍額定輸出扭矩 2 Time of Rated Output Torque
慣性慣量 / Inertia Moment		kg.m ²	777×10^{-7}
出力容許轉速 / Output Permissible Speed		rpm	300
回程間隙 / Torsional Backlash		arcmin	≤ 1
動態齒隙差 / Lost Motion		arcmin	2 (0.033°)
重覆定位精度 / Repetitive Positioning Accuracy		arcsec	±10 (0.0028°)
容許載重 / Permissible Thrust Load		N	350
容許慣量載重 / Permissible Moment Load		N.m	7
工作台面偏擺 / Runout of Output Table Surface		mm	0.01
工作台同心度 / Runout of Output Table Inner / Outer Diameter		mm	0.01
工作台平行度 / Parallelism of Output Table		mm	0.02
防護等級 / Protection Class			IP 65
重量 / Weight		Kg	

MODEL : GT-85H

RATIO : 10.18 (單段 1-Stage)



Unit: mm

Model Code	85
A1	46 · 63 · 60
A2	M3 · M4 · M5
A3	30 · 40 · 50
A4	46 · 55

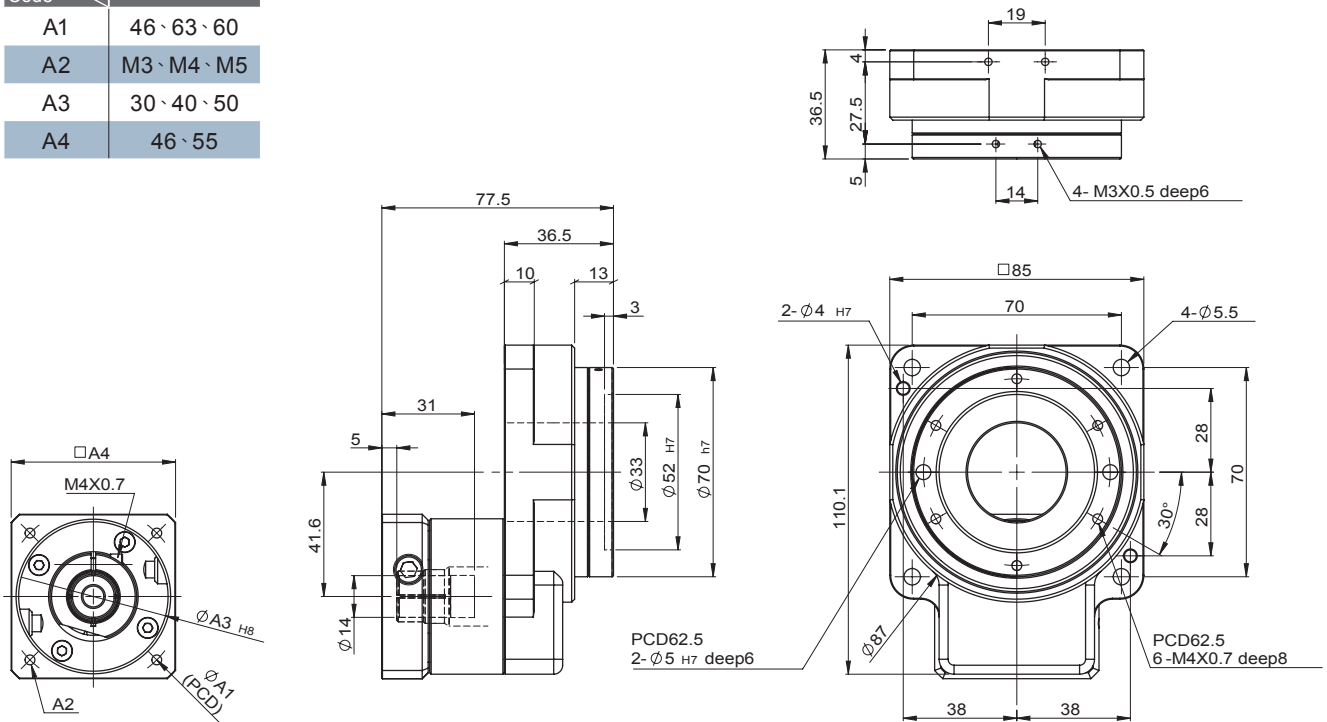

特性 Characteristic	代號	單位 Unit	GT-85H
輸出平台支撐軸承 / Output Table Supporting Bearing			交叉斜角滾柱軸承大中空 Crossed Roller Bearings
額定輸出扭矩 / Rated Output Torque		N.m	18
最大輸出扭矩 / Max. Output Torque 急停扭矩 / Emergency Stop Torque	T_{2NOT}	N.m	2 倍額定輸出扭矩 2 Time of Rated Output Torque
慣性慣量 / Inertia Moment		kg.m ²	$1,203 \times 10^{-6}$
出力容許轉速 / Output Permissible Speed		rpm	200
回程間隙 / Torsional Backlash		arcmin	≤ 1
動態齒隙差 / Lost Motion		arcmin	2 (0.033°)
重覆定位精度 / Repetitive Positioning Accuracy		arcsec	± 10 (0.0028°)
容許載重 / Permissible Thrust Load		N	900
容許慣量載重 / Permissible Moment Load		N.m	18
工作台面偏擺 / Runout of Output Table Surface		mm	0.01
工作台同心度 / Runout of Output Table Inner / Outer Diameter		mm	0.01
工作台平行度 / Parallelism of Output Table		mm	0.02
防護等級 / Protection Class			IP 65
重量 / Weight		Kg	

MODEL : GT-85H

RATIO : 50.100 (雙段 2-Stage)

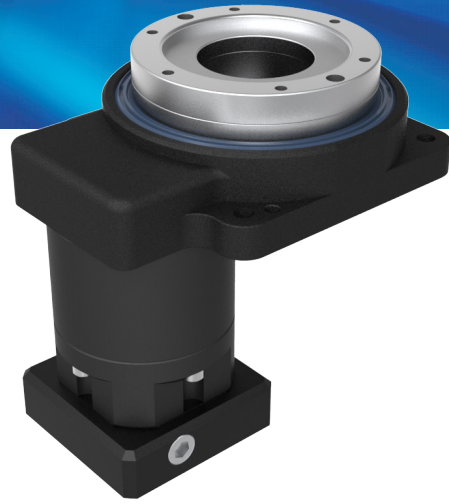

GT

Unit: mm

Model Code	85
A1	46 · 63 · 60
A2	M3 · M4 · M5
A3	30 · 40 · 50
A4	46 · 55

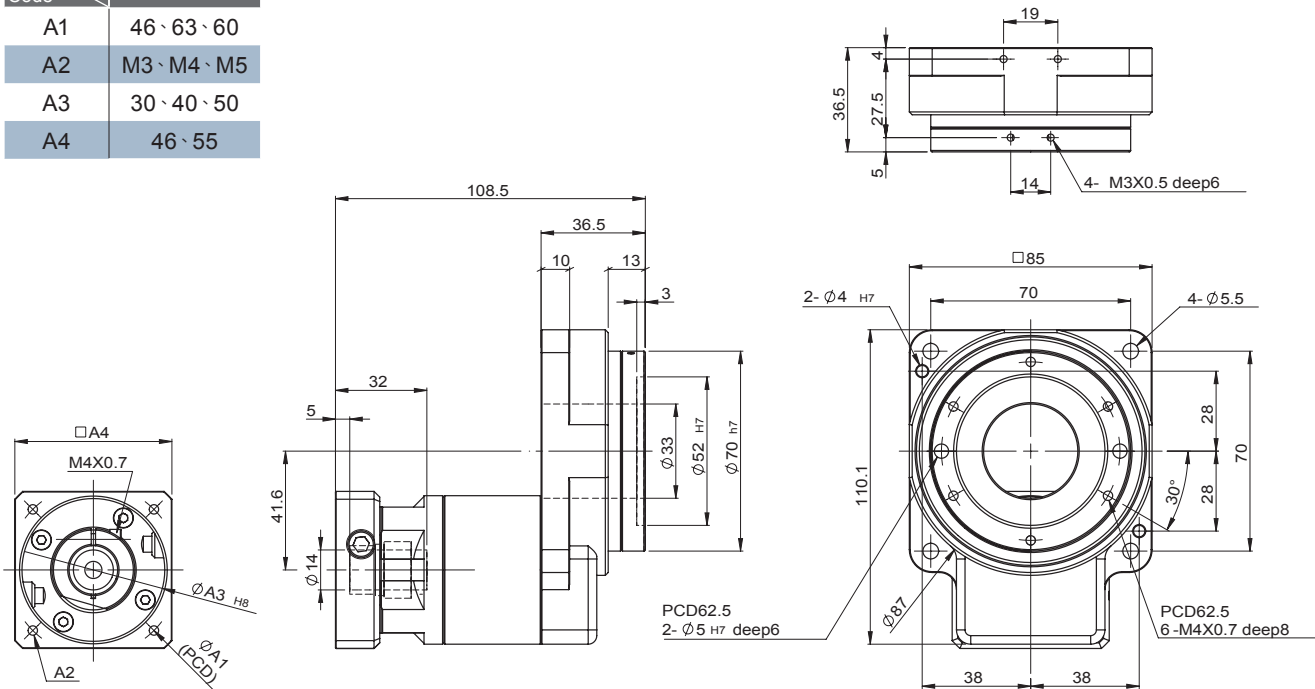

特性 Characteristic	代號	單位 Unit	GT-85H
輸出平台支撐軸承 / Output Table Supporting Bearing			交叉斜角滾柱軸承大中空 Crossed Roller Bearings
額定輸出扭矩 / Rated Output Torque		N.m	18
最大輸出扭矩 / Max. Output Torque 急停扭矩 / Emergency Stop Torque	T_{2NOT}	N.m	2 倍額定輸出扭矩 2 Time of Rated Output Torque
慣性慣量 / Inertia Moment		kg.m ²	$1,203 \times 10^{-6}$
出力容許轉速 / Output Permissible Speed		rpm	200
回程間隙 / Torsional Backlash		arcmin	≤ 1
動態齒隙差 / Lost Motion		arcmin	2 (0.033°)
重覆定位精度 / Repetitive Positioning Accuracy		arcsec	±10 (0.0028°)
容許載重 / Permissible Thrust Load		N	900
容許慣量載重 / Permissible Moment Load		N.m	18
工作台面偏擺 / Runout of Output Table Surface		mm	0.01
工作台同心度 / Runout of Output Table Inner / Outer Diameter		mm	0.01
工作台平行度 / Parallelism of Output Table		mm	0.02
防護等級 / Protection Class			IP 65
重量 / Weight		Kg	

MODEL : GT-110H

RATIO : 10.18 (單段 1-Stage)

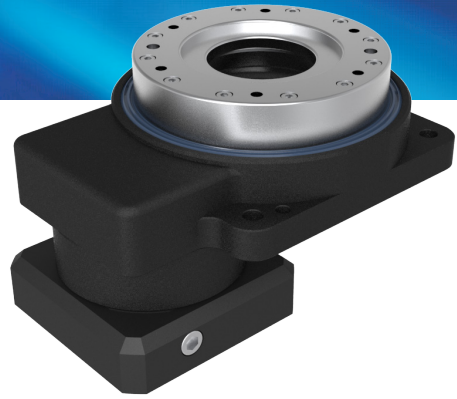

Unit: mm

Model Code	110
A1	70 · 75 · 90
A2	M4 · M5 · M6
A3	50 · 60 · 70
A4	64 · 70 · 80

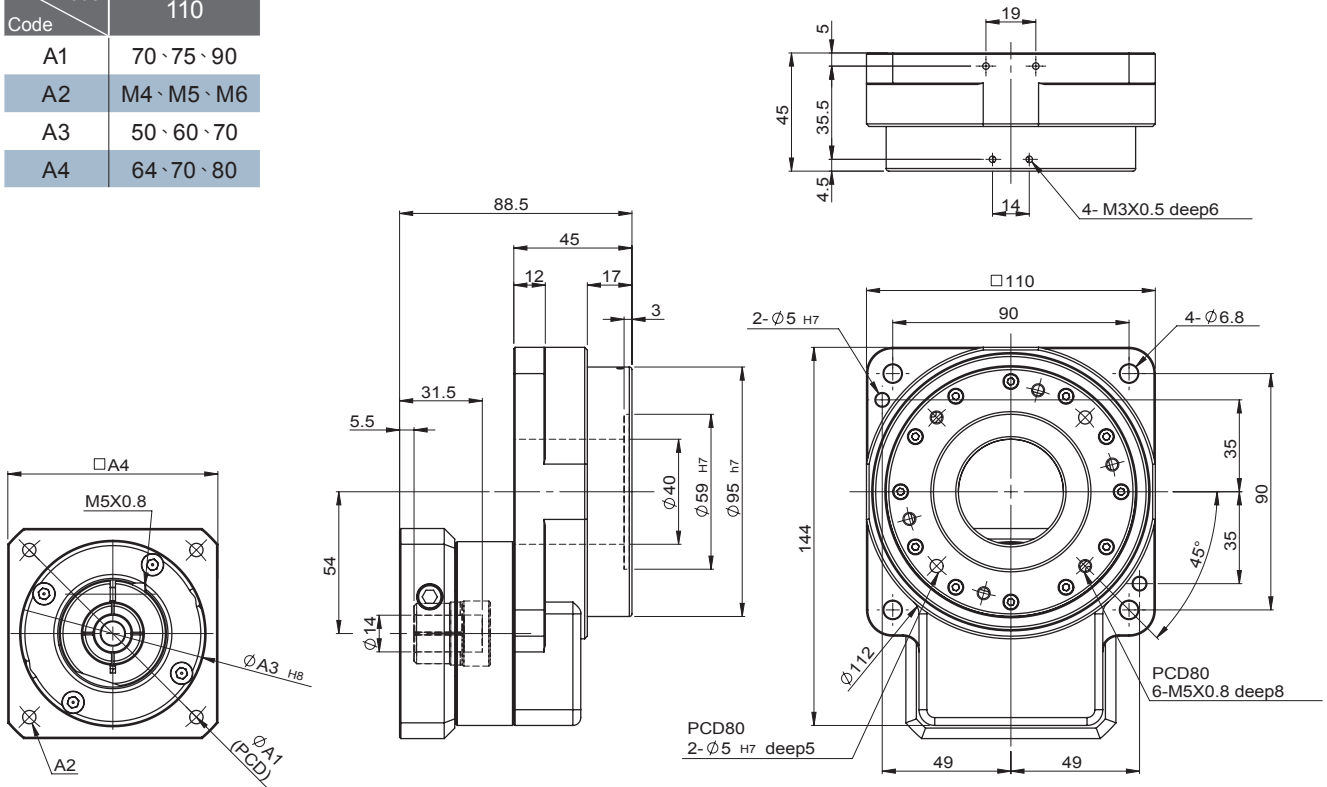

特性 Characteristic	代號	單位 Unit	GT-110H
輸出平台支撐軸承 / Output Table Supporting Bearing			交叉斜角滾柱軸承大中空 Crossed Roller Bearings
額定輸出扭矩 / Rated Output Torque		N.m	33
最大輸出扭矩 / Max. Output Torque 急停扭矩 / Emergency Stop Torque	T_{2NOT}	N.m	2 倍額定輸出扭矩 2 Time of Rated Output Torque
慣性慣量 / Inertia Moment		kg.m ²	$1,483 \times 10^{-6}$
出力容許轉速 / Output Permissible Speed		rpm	200
回程間隙 / Torsional Backlash		arcmin	≤ 1
動態齒隙差 / Lost Motion		arcmin	2 (0.033°)
重覆定位精度 / Repetitive Positioning Accuracy		arcsec	±10 (0.0028°)
容許載重 / Permissible Thrust Load		N	1,200
容許慣量載重 / Permissible Moment Load		N.m	24
工作台面偏擺 / Runout of Output Table Surface		mm	0.015
工作台同心度 / Runout of Output Table Inner / Outer Diameter		mm	0.015
工作台平行度 / Parallelism of Output Table		mm	0.025
防護等級 / Protection Class			IP 65
重量 / Weight		Kg	

MODEL : GT-110H

RATIO : 50.100 (雙段 2-Stage)

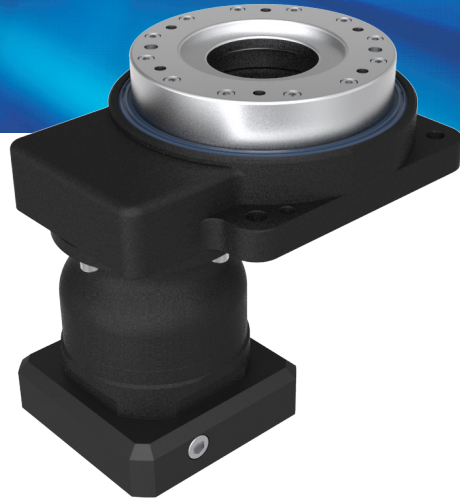

Unit: mm

Model Code	110
A1	70 · 75 · 90
A2	M4 · M5 · M6
A3	50 · 60 · 70
A4	64 · 70 · 80

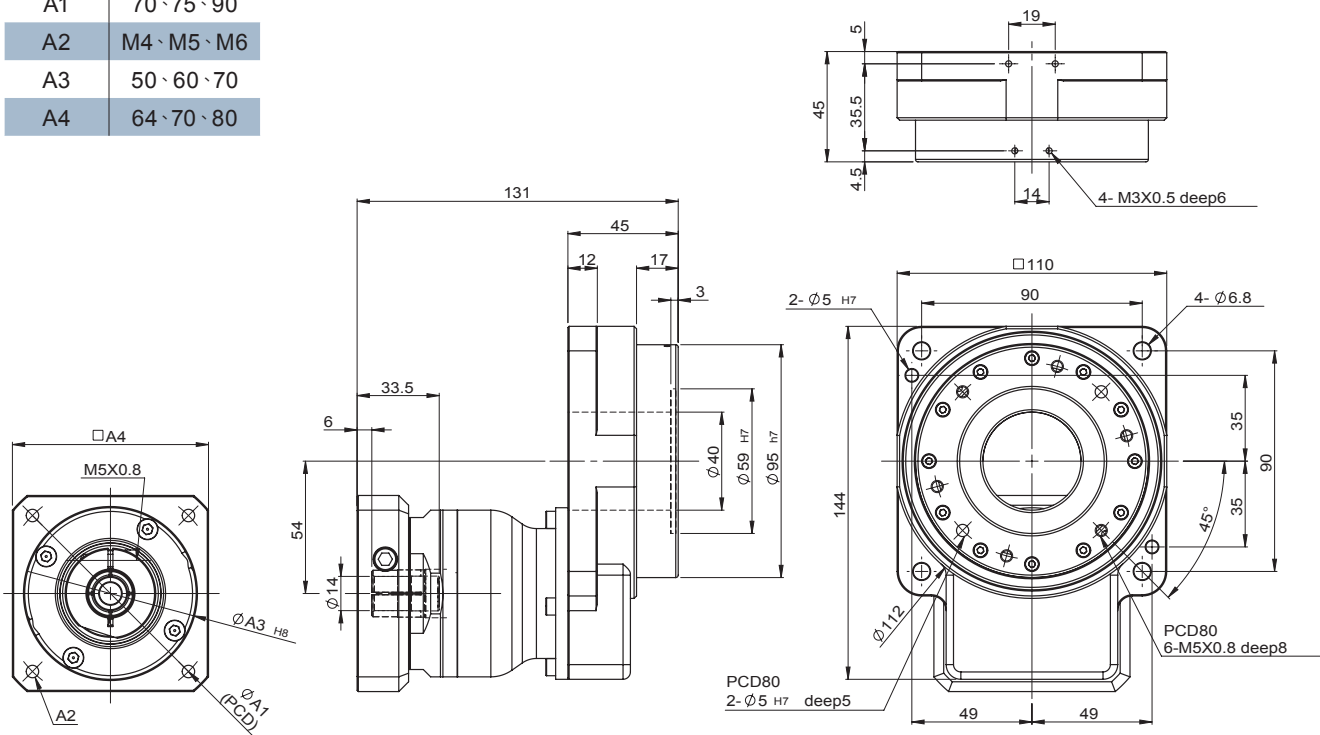

特性 Characteristic	代號	單位 Unit	GT-110H
輸出平台支撐軸承 / Output Table Supporting Bearing			交叉斜角滾柱軸承大中空 Crossed Roller Bearings
額定輸出扭矩 / Rated Output Torque		N.m	33
最大輸出扭矩 / Max. Output Torque 急停扭矩 / Emergency Stop Torque	T_{2NOT}	N.m	2 倍額定輸出扭矩 2 Time of Rated Output Torque
慣性慣量 / Inertia Moment		kg.m ²	1,483 x 10 ⁻⁶
出力容許轉速 / Output Permissible Speed		rpm	200
回程間隙 / Torsional Backlash		arcmin	≤ 1
動態齒隙差 / Lost Motion		arcmin	2 (0.033°)
重覆定位精度 / Repetitive Positioning Accuracy		arcsec	±10 (0.0028°)
容許載重 / Permissible Thrust Load		N	1,200
容許慣量載重 / Permissible Moment Load		N.m	24
工作台面偏擺 / Runout of Output Table Surface		mm	0.015
工作台同心度 / Runout of Output Table Inner / Outer Diameter		mm	0.015
工作台平行度 / Parallelism of Output Table		mm	0.025
防護等級 / Protection Class			IP 65
重量 / Weight		Kg	

MODEL : GT-135H

RATIO : 10.18 (單段 1-Stage)

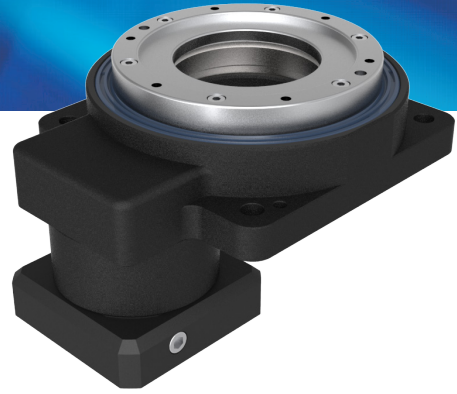

Unit: mm

Model Code	135
A1	70 · 75 · 90
A2	M4 · M5 · M6
A3	50 · 60 · 70
A4	64 · 70 · 80

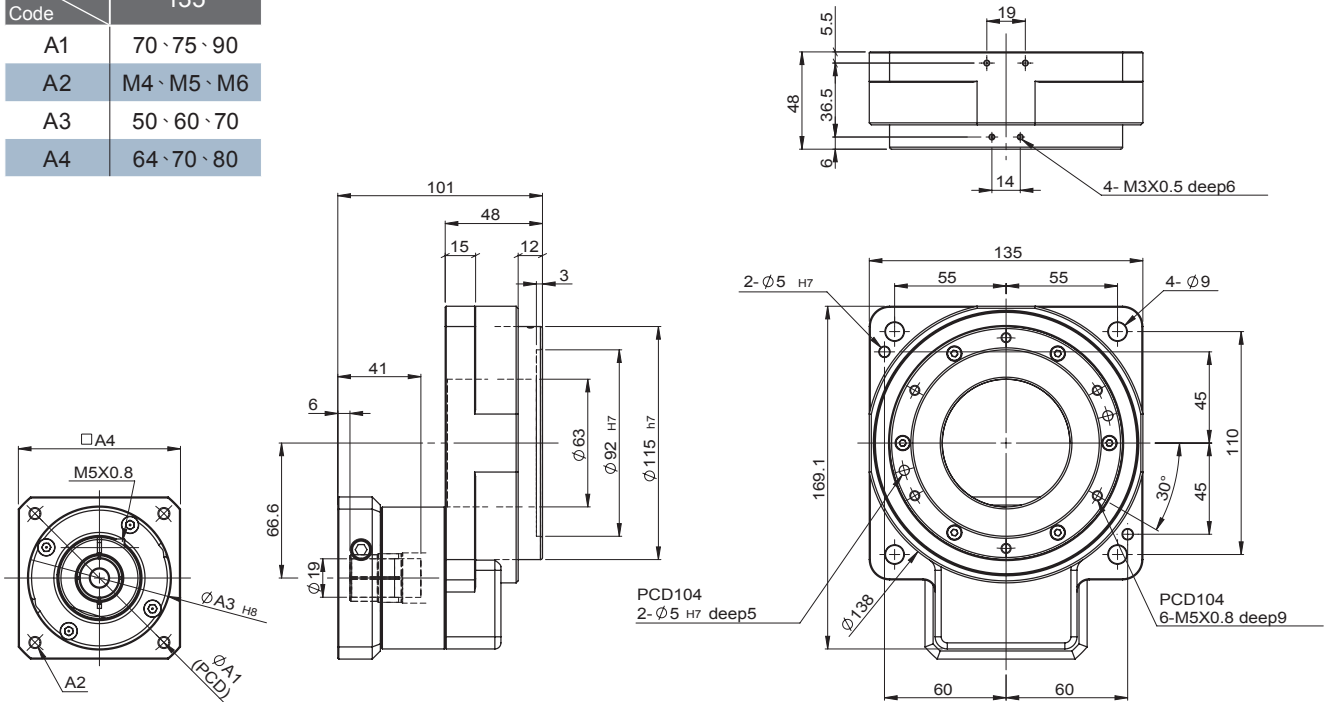

特性 Characteristic	代號	單位 Unit	GT-135H
輸出平台支撐軸承 / Output Table Supporting Bearing			交叉斜角滾柱軸承大中空 Crossed Roller Bearings
額定輸出扭矩 / Rated Output Torque		N.m	43
最大輸出扭矩 / Max. Output Torque 急停扭矩 / Emergency Stop Torque	T_{2NOT}	N.m	2 倍額定輸出扭矩 2 Time of Rated Output Torque
慣性慣量 / Inertia Moment		kg.m ²	$2,772 \times 10^{-6}$
出力容許轉速 / Output Permissible Speed		rpm	200
回程間隙 / Torsional Backlash		arcmin	≤ 1
動態齒隙差 / Lost Motion		arcmin	2 (0.033°)
重覆定位精度 / Repetitive Positioning Accuracy		arcsec	±10 (0.0028°)
容許載重 / Permissible Thrust Load		N	2,200
容許慣量載重 / Permissible Moment Load		N.m	45
工作台面偏擺 / Runout of Output Table Surface		mm	0.015
工作同心度 / Runout of Output Table Inner / Outer Diameter		mm	0.015
工作平台平行度 / Parallelism of Output Table		mm	0.025
防護等級 / Protection Class			IP 65
重量 / Weight		Kg	

MODEL : GT-135H

RATIO : 50.100 (雙段 2-Stage)

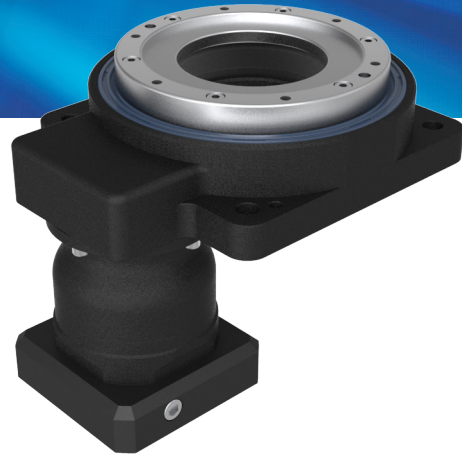

Unit: mm

Model Code	135
A1	70 · 75 · 90
A2	M4 · M5 · M6
A3	50 · 60 · 70
A4	64 · 70 · 80

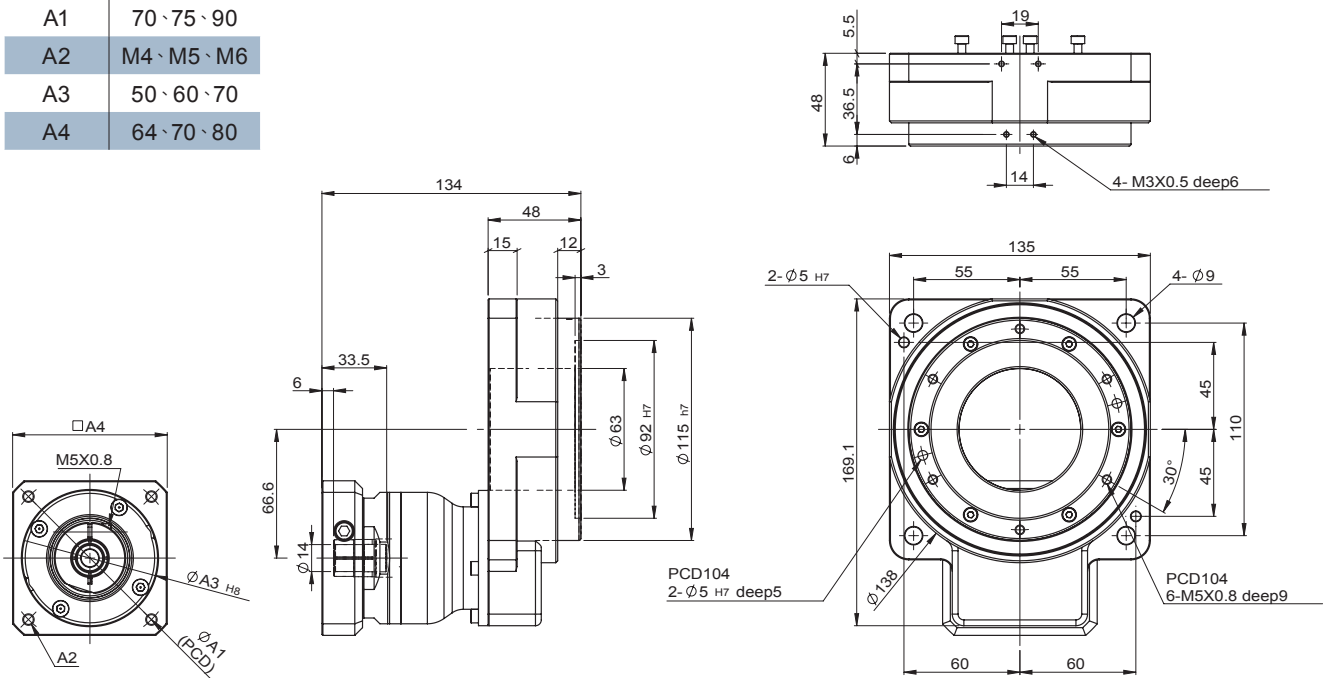

特性 Characteristic	代號	單位 Unit	GT-135H
輸出平台支撐軸承 / Output Table Supporting Bearing			交叉斜角滾柱軸承大中空 Crossed Roller Bearings
額定輸出扭矩 / Rated Output Torque		N.m	43
最大輸出扭矩 / Max. Output Torque 急停扭矩 / Emergency Stop Torque	T_{2NOT}	N.m	2 倍額定輸出扭矩 2 Time of Rated Output Torque
慣性慣量 / Inertia Moment		kg.m ²	$2,772 \times 10^{-6}$
出力容許轉速 / Output Permissible Speed		rpm	200
回程間隙 / Torsional Backlash		arcmin	≤ 1
動態齒隙差 / Lost Motion		arcmin	2 (0.033°)
重覆定位精度 / Repetitive Positioning Accuracy		arcsec	±10 (0.0028°)
容許載重 / Permissible Thrust Load		N	2,200
容許慣量載重 / Permissible Moment Load		N.m	45
工作台面偏擺 / Runout of Output Table Surface		mm	0.015
工作台同心度 / Runout of Output Table Inner / Outer Diameter		mm	0.015
工作台平行度 / Parallelism of Output Table		mm	0.025
防護等級 / Protection Class			IP 65
重量 / Weight		Kg	

MODEL : GT-200H

RATIO : 10.18 (單段 1-Stage)

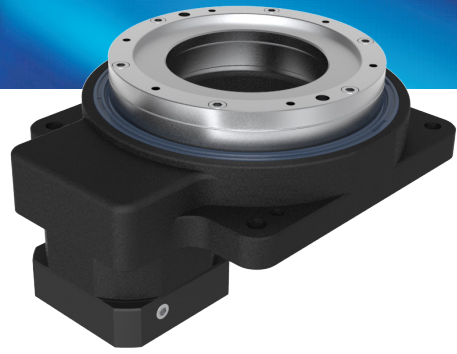

Unit: mm

Model Code	200
A1	90 · 100 · 115 · 145
A2	M5 · M6 · M8
A3	70 · 80 · 95 · 110
A4	92 · 110 · 130
A5	19 · 24
A6	44.5 · 57.5
A7	8.5 · 7.5
A8	113.5 · 126.5

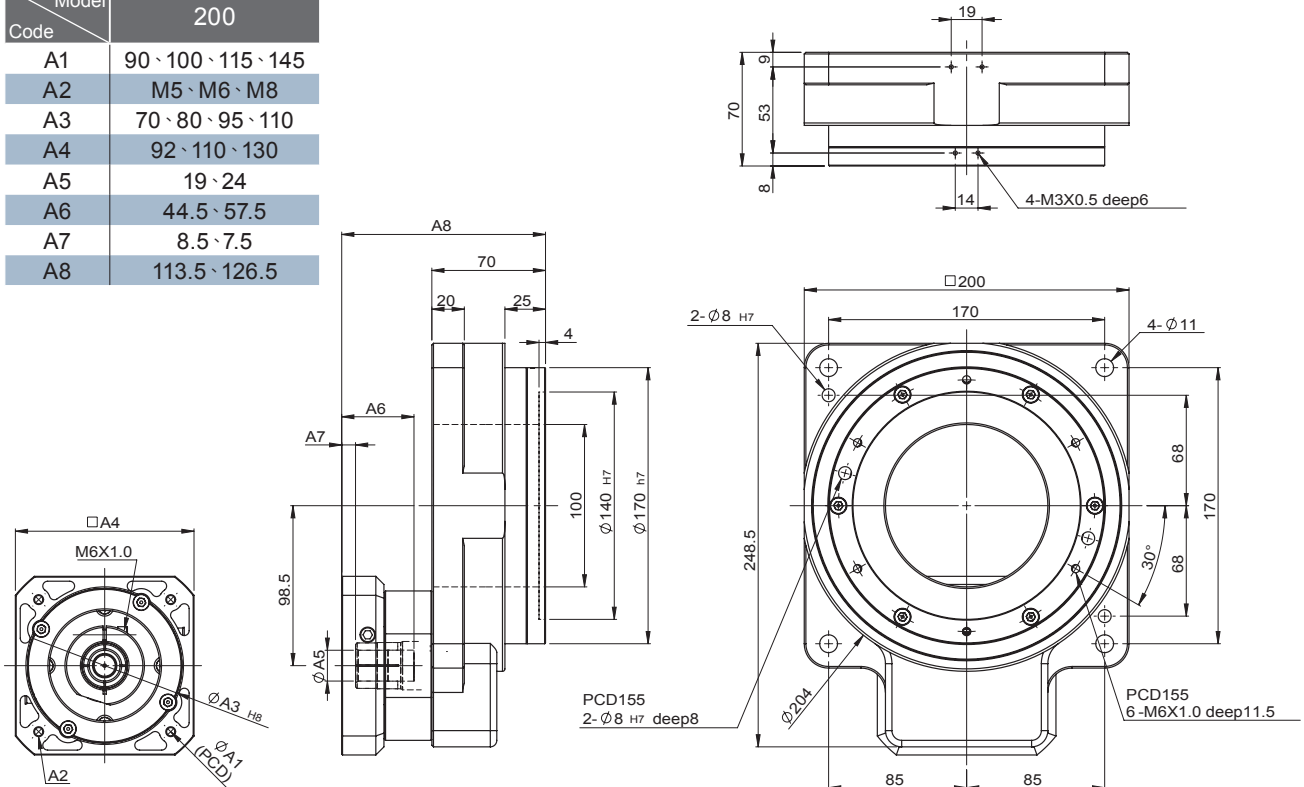

特性 Characteristic	代號	單位 Unit	GT-200H
輸出平台支撐軸承 / Output Table Supporting Bearing			交叉斜角滾柱軸承大中空 Crossed Roller Bearings
額定輸出扭矩 / Rated Output Torque		N.m	142
最大輸出扭矩 / Max. Output Torque 急停扭矩 / Emergency Stop Torque	T_{2NOT}	N.m	2 倍額定輸出扭矩 2 Time of Rated Output Torque
慣性慣量 / Inertia Moment		kg.m ²	27,619 x 10 ⁻⁶
出力容許轉速 / Output Permissible Speed		rpm	200
回程間隙 / Torsional Backlash		arcmin	≤ 1
動態齒隙差 / Lost Motion		arcmin	2 (0.033°)
重覆定位精度 / Repetitive Positioning Accuracy		arcsec	±10 (0.0028°)
容許載重 / Permissible Thrust Load		N	4,000
容許慣量載重 / Permissible Moment Load		N.m	120
工作台面偏擺 / Runout of Output Table Surface		mm	0.02
工作台同心度 / Runout of Output Table Inner / Outer Diameter		mm	0.02
工作台平行度 / Parallelism of Output Table		mm	0.03
防護等級 / Protection Class			IP 65
重量 / Weight		Kg	

MODEL : GT-200H

RATIO : 50.100 (雙段 2-Stage)

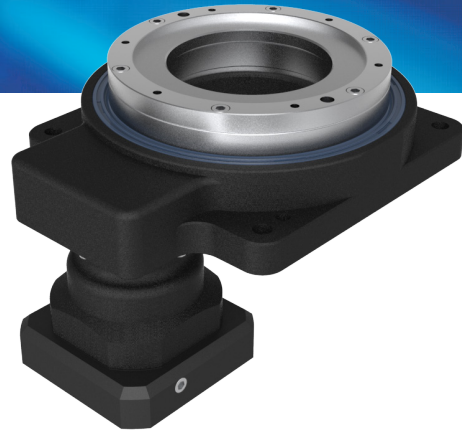

GT

Unit: mm

Model Code	200
A1	90、100、115、145
A2	M5、M6、M8
A3	70、80、95、110
A4	92、110、130

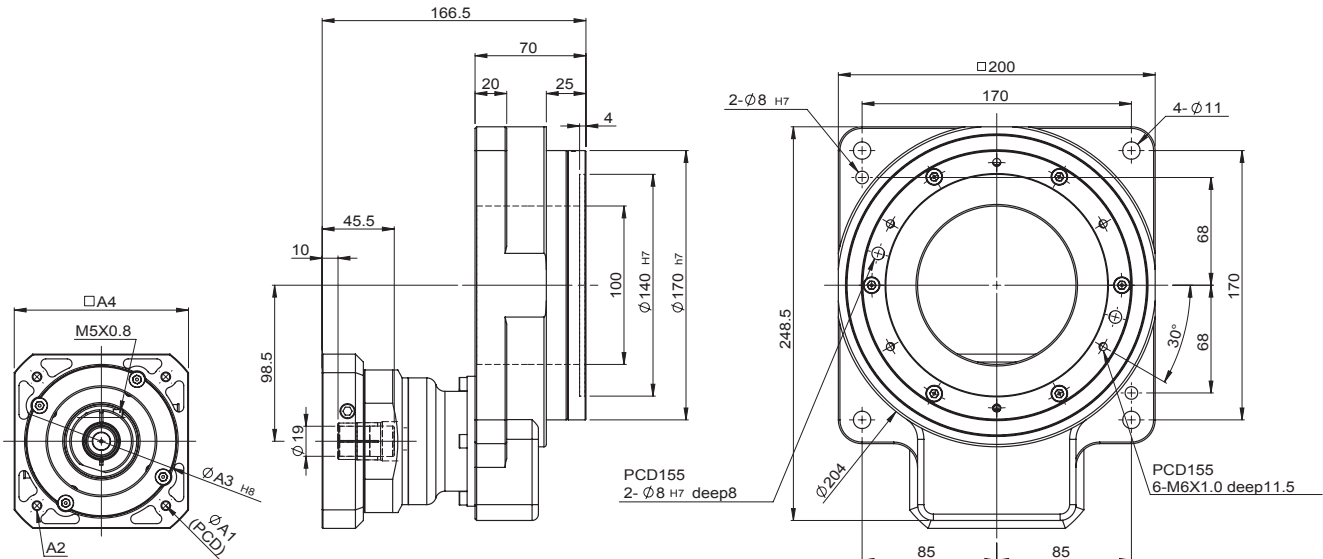
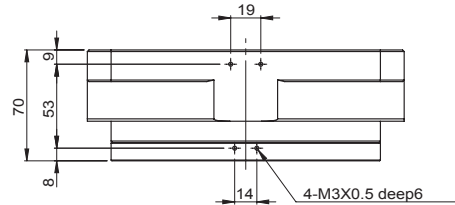

特性 Characteristic	代號	單位 Unit	GT-200H
輸出平台支撐軸承 / Output Table Supporting Bearing			交叉斜角滾柱軸承大中空 Crossed Roller Bearings
額定輸出扭矩 / Rated Output Torque		N.m	142
最大輸出扭矩 / Max. Output Torque 急停扭矩 / Emergency Stop Torque	T_{2NOT}	N.m	2 倍額定輸出扭矩 2 Time of Rated Output Torque
慣性慣量 / Inertia Moment		kg.m ²	27,619 x 10 ⁻⁶
出力容許轉速 / Output Permissible Speed		rpm	200
回程間隙 / Torsional Backlash		arcmin	≤ 1
動態齒隙差 / Lost Motion		arcmin	2 (0.033°)
重覆定位精度 / Repetitive Positioning Accuracy		arcsec	±10 (0.0028°)
容許載重 / Permissible Thrust Load		N	4,000
容許慣量載重 / Permissible Moment Load		N.m	120
工作台面偏擺 / Runout of Output Table Surface		mm	0.02
工作台同心度 / Runout of Output Table Inner / Outer Diameter		mm	0.02
工作台平行度 / Parallelism of Output Table		mm	0.03
防護等級 / Protection Class			IP 65
重量 / Weight		Kg	

MODEL : GT-250H

RATIO : 10.18 (單段 1-Stage)

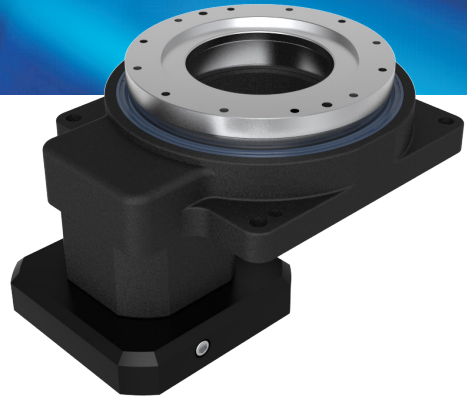

Unit: mm

Model Code	250
A1	115 · 145 · 200
A2	M6 · M8 · M12
A3	95 · 110 · 114.3
A4	122 · 130 · 180

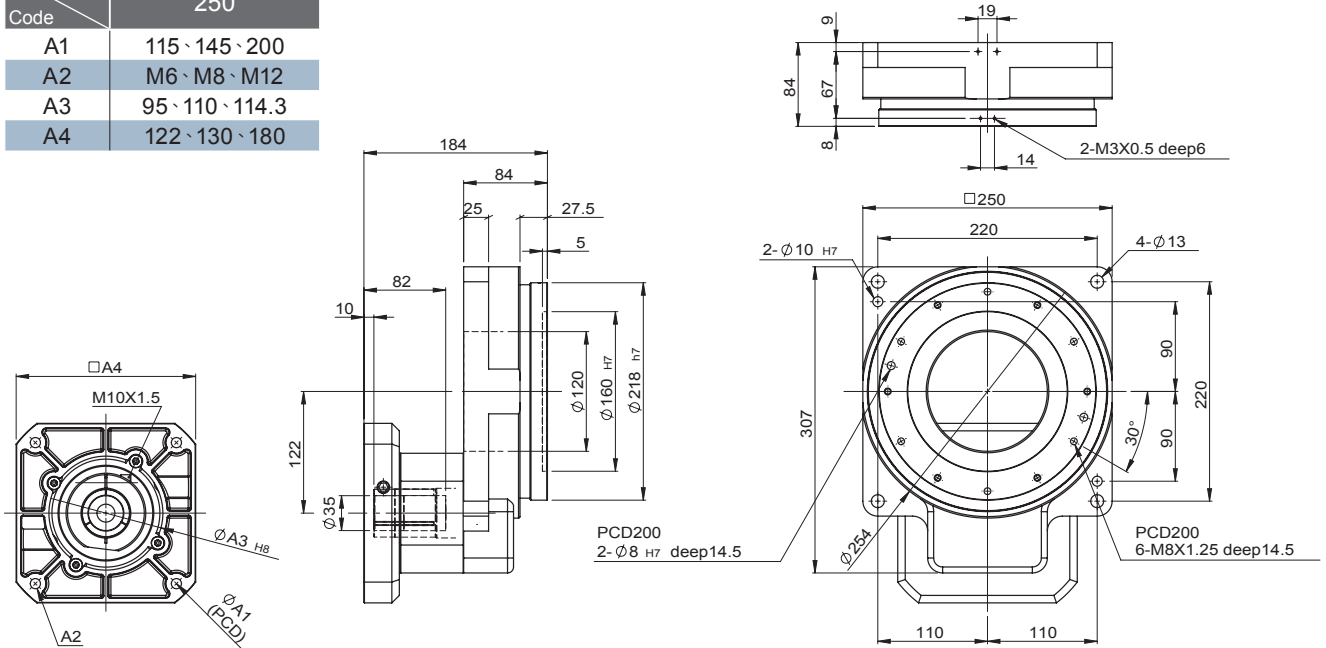

特性 Characteristic	代號	單位 Unit	GT-250H
輸出平台支撐軸承 / Output Table Supporting Bearing			交叉斜角滾柱軸承大中空 Crossed Roller Bearings
額定輸出扭矩 / Rated Output Torque		N.m	312
最大輸出扭矩 / Max. Output Torque 急停扭矩 / Emergency Stop Torque	T_{2NOT}	N.m	2 倍額定輸出扭矩 2 Time of Rated Output Torque
慣性慣量 / Inertia Moment		kg.m ²	53,551 x 10 ⁻⁶
出力容許轉速 / Output Permissible Speed		rpm	200
回程間隙 / Torsional Backlash		arcmin	≤ 1
動態齒隙差 / Lost Motion		arcmin	2 (0.033°)
重覆定位精度 / Repetitive Positioning Accuracy		arcsec	±10 (0.0028°)
容許載重 / Permissible Thrust Load		N	5,060
容許慣量載重 / Permissible Moment Load		N.m	200
工作台面偏擺 / Runout of Output Table Surface		mm	0.025
工作台同心度 / Runout of Output Table Inner / Outer Diameter		mm	0.025
工作台平行度 / Parallelism of Output Table		mm	0.035
防護等級 / Protection Class			IP 65
重量 / Weight		Kg	

Glossary

減速機專用名詞解釋

輸出平台支撐軸承

使用於輸出平台的軸承種類。

Output Table Supporting Bearing

This is the type of the bearing used for the output table.

額定輸出扭矩 [N.m]

指減速機長時間可以加載的扭矩。

Retard Output Torque [N.m]

This is the limit of mechanical strength of the speed reduction mechanism. Make sure that the applied torque, including the acceleration torque and load fluctuation, does not exceed the permissible torque.

最大輸出扭矩 / 急停扭矩 (T_{2NOT}) [N.m]

指減速機輸出端所能加載的最大扭矩。這個扭矩可在減速機壽命期內加載 1000 次。超過 1000 次可能會造成內部零件的破壞。(備註: GT 系列機型為 $T_{2NOT} = 2 \cdot T_{2B}$; 即 2 倍額定輸出扭矩)。

Max. Output Torque / Emergency Stop Torque (T_{2NOT}) [N.m]

The emergency stop torque T_{2NOT} is the maximum permissible torque at the gearbox output end and must not be reached more than 1000 times during the service life of the gearbox. It must never be exceeded to prevent inside parts from damage. LIMING GT $T_{2NOT} = 2 \cdot T_{2B}$ (2 times of rated output torque)

慣性慣量 [kg.m²]

減速機構部慣性慣量至輸出的值。

Inertia Moment [kg.m²]

This is the total sum of the inertial moment of the speed reduction mechanism converted to a moment on the output table.

出力容許轉速 [rpm]

減速機的機械性強度·可容許的輸出平台轉速。

Output Permissible Speed [rpm]

This is the output table speed that can be tolerated by the mechanical strength of the speed reduction mechanism.

回程間隙 (j_r) [arcmin]

指減速機輸出軸與輸入端的最大偏差角·測量時先將齒輪輸入端固定住·然後在輸出軸加載額定扭矩的 2% 扭矩·減速機輸出端正反轉時有一個微小的角位移·此角位移即為回程間隙·單位是 " 弧分 "·即一度的六十分之一度。

Torsional Backlash (j_t) [arcmin]

Torsional backlash j_t is the maximum angle of torsion of the output shaft in relation to the input. Torsional backlash is measured with the input shaft locked. The output is then loaded with a defined test torque (2% rated output torque) in order to overcome the internal gearhead friction. The main factor affecting torsional backlash is the face clearance between the gear teeth.

動態齒隙差 [arcmin]

即正反轉定位精度差·將輸出平台在某個位置從正轉方向定位時·與從逆轉方向在相同位置定位時停止角度之差。

Lost Motion [arcmin]

This is the difference in stopped angles achieved when the output table is positioned to the same position in the forward and reverse directions.

Glossary

減速機專用名詞解釋

重覆定位精度 [arcsec]

在同位置從同方向反覆定位所產生誤差值。

Repetitive Positioning Accuracy [arcsec]

This is a value indicating the degree of error that generates when positioning is performed repeatedly to the same position in the same direction.

容許載重 [N]

表示施加在輸出平台的軸方向推力載重的容許值。

Permissible Thrust Load [N]

This is the permissible value of thrust load applied to the output table in the axial direction.

容許慣量載重 [N.m]

在從輸出平台中心偏心的位置施加载重時，產生使輸出平台傾斜的作用力。
是指離此時中心的偏心量 × 載重而計算的慣量載重容許值。

Permissible Moment Load [N.m]

When a load is applied to a position away from the center of the output table, the output table receives a tilting force. The permissible moment load refers to the permissible value of moment load calculated by the eccentricity from the center by the applied load.

工作台面偏擺 [mm]

指無負載下輸出平台運轉時，輸出平台安裝面的偏轉最大值。

Runout of Output Table Surface [mm]

This is the max. value of runout of the installation surface of the output table when the output table is rotated under no load.

工作台同心度 [mm]

指無負載下使輸出平台運轉時，平台內徑或外徑的偏轉度最大值。

Runout of Output Table Inner / Outer Diameter [mm]

This is the max. value of runout of the inner diameter or outer diameter of the table when the output table is rotated under no load.

工作台平行度 [mm]

減速機安裝面與輸出平台的安裝面傾斜的程度。

Parallelism of Output Table [mm]

This is the inclination of the installation surface of the output table compared with the actuator installation surface on the equipment side.

防護等級

按照 IP65，就保護構造，將防塵性、防水性按等級分類。

Protection Class

Based on IP65, dustresistance and waterproofing regarding the degree of protection of the device is classified using a grade.

重量 Weight [kg]

實物重量。 Product weight.

Permissible Moment Load

容許慣量載重

GT

GT60/GT85/GT110/GT135/GT200

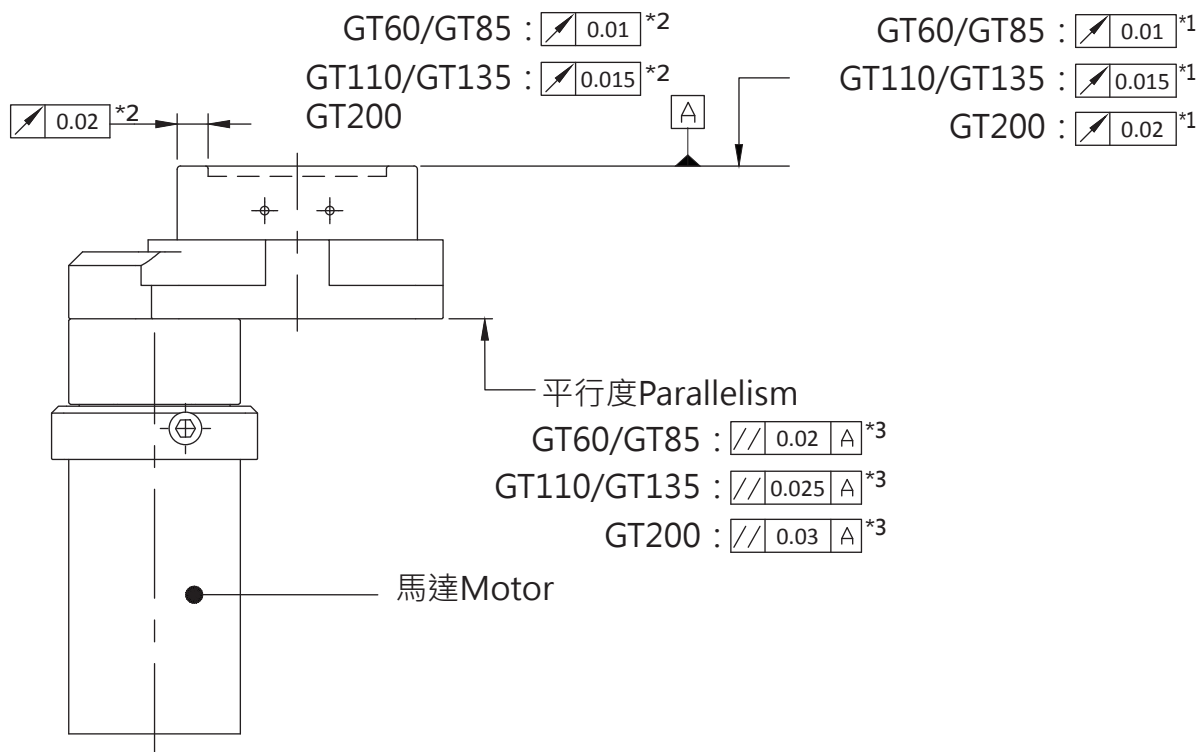

- * 1 輸出平台面振幅
Runout of output table surface
- * 2 輸出平台內外徑振幅
Runout of output table inner and outer diameter
- * 3 輸出平台平行度 (安裝面標準)
Parallelism of output table (against the installation surface)

工作台面偏擺：指無負載下輸出平台運轉時，輸出平台安裝面的偏轉最大值。

工作台同心度：指無負載下使輸出平台運轉時，平台內徑或外徑的偏轉度最大值。

工作台平行度：減速機安裝面與輸出平台的安裝面傾斜的程度。

Runout of Output Table Surface: This is the max. value of runout of the installation surface of the output table when the output table is rotated under no load.

Runout of Output Table Inner / Outer Diameter: This is the max. value of runout of the inner diameter or outer diameter of the table when the output table is rotated under no load.

Parallelism of Output Table: This is the inclination of the installation surface of the output table compared with the actuator installation surface on the equipment side.

Permissible Moment Load

容許慣量載重

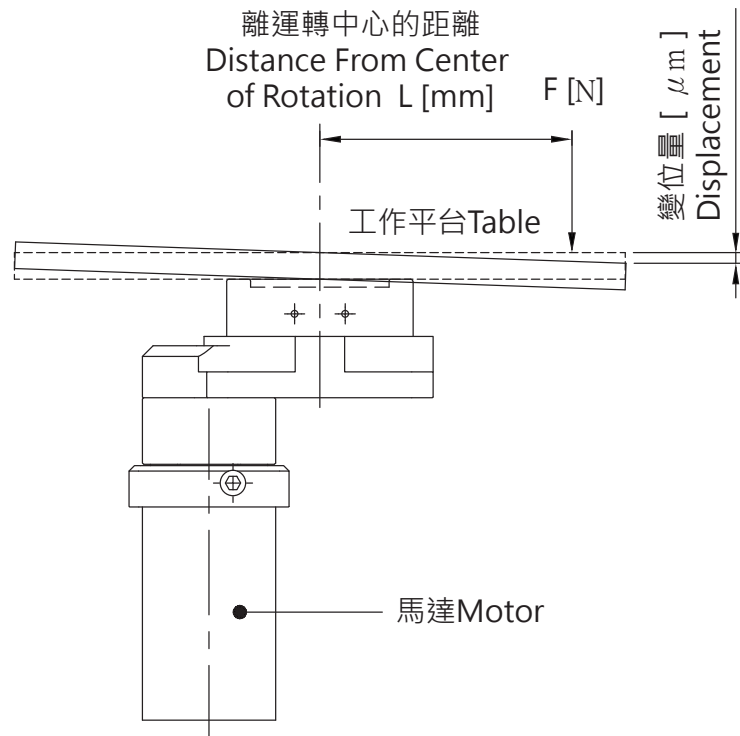

$$\text{慣量載重 Moment Load [Nm]} = 0.001 \times F(\text{N}) \times L(\text{mm})$$

慣量載重引起的變位量 (參考值)

在輸台上施加慣量載重時會引起變位。

圖表上的變位量是使慣量載重作用一個方向時，自輸出平台運轉中心距離 L 的變位量。

慣量載重在正負兩方向作用時，變位量約為 2 倍。

Displacement by Moment Load (Reference Value)

The output table will be displaced when it receives the moment load.

The graph plots the table displacement that occurs at distance L from the rotation center of the output table when a given moment load is applied in the negative direction.

The displacement becomes approximately twofold when the moment load is applied in both the positive and negative directions.

Applications

減速機應用範例

○施加力矩負載的應用

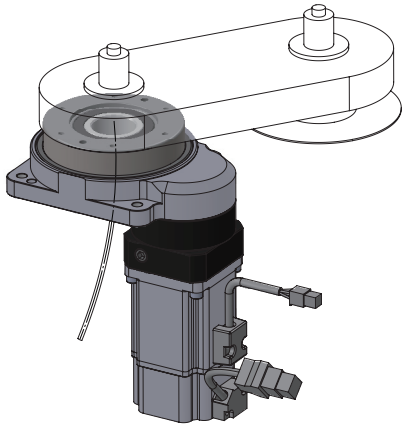

○高精度定位應用

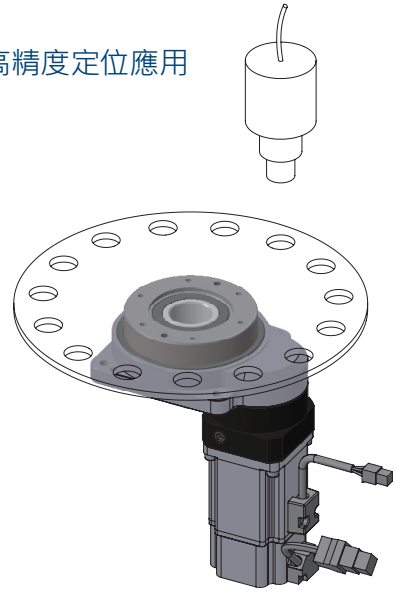

○使用中空孔光學應用

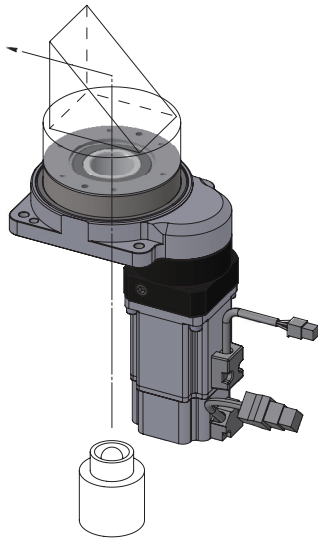

○使用中空孔的應用

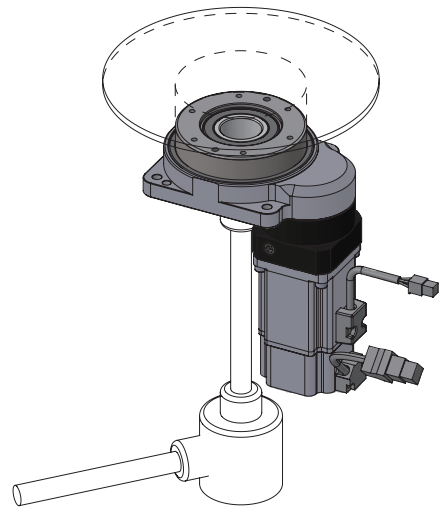

○高精度中空孔定位應用

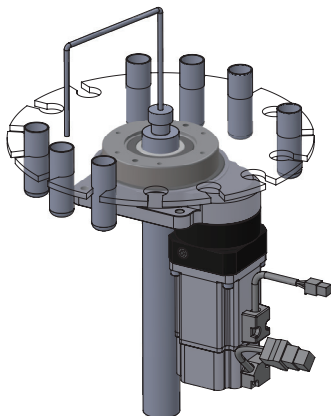

○綜合應用

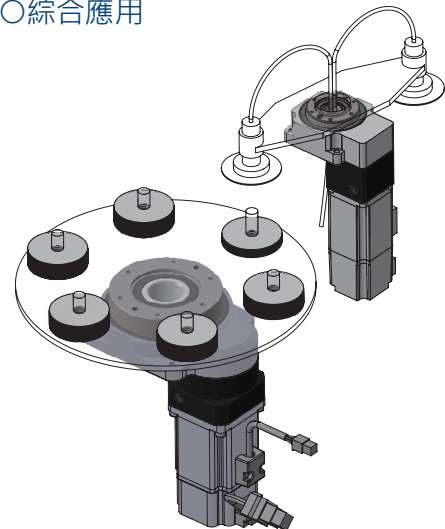

Hollow Rotary Reducer and Motor Mounting Instructions

高精度中空旋轉平台減速機與馬達安裝指南



1

核對馬達型號與減速機規格是否正確。並將配合面擦拭乾淨。

Confirm the motor, and gearbox size. Clean up the mounting surface.

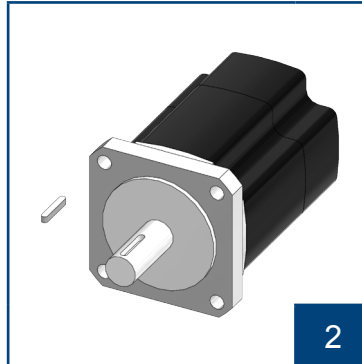

2

如馬達軸徑在 $\varnothing 35$ 以下，請將馬達軸上的鍵拿掉。

Remove the motor key if the diameter of motor shaft is under $\varnothing 35$.



3

檢查馬達出力軸尺寸，如需軸套，請先裝進入力孔內。

Check motor shaft size and insert bushing into input bore if necessary.



4

取出塞頭，使用六角板手將迫緊環螺絲鬆開。並將螺絲對準孔位。

Remove the plug on the adapter plate. Rotate the set collar till the bolt is line up.



5

將馬達垂直裝入減速機。

Put the motor into the gearbox vertically.



6

依序使用扭力板手鎖上外六角螺絲。

Tighten the mounting bolt in 1~4 order with torque wrench.

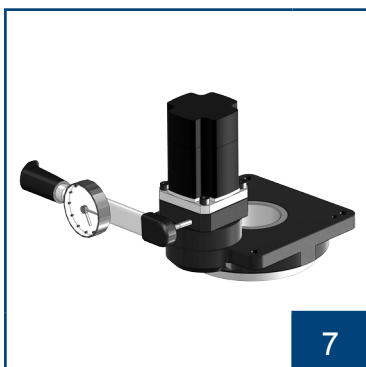

7

使用扭力板手將迫緊環螺絲鎖緊。

Tighten the set collar bolt with torque wrench.



8

裝回塞頭。

Tighten back the screw plug.

1. 務必先鎖緊馬達，才能鎖緊馬達軸心迫緊環。

To be sure to tighten motor first and then to tighten the set collar on motor shaft.

2. 請依步驟順序組裝，尤其步驟 6、7 不可顛倒。

Please assembly in order according to above steps, especially for step 6 and step 7.

Bushing

軸套

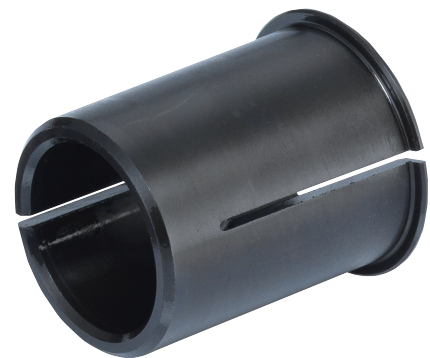
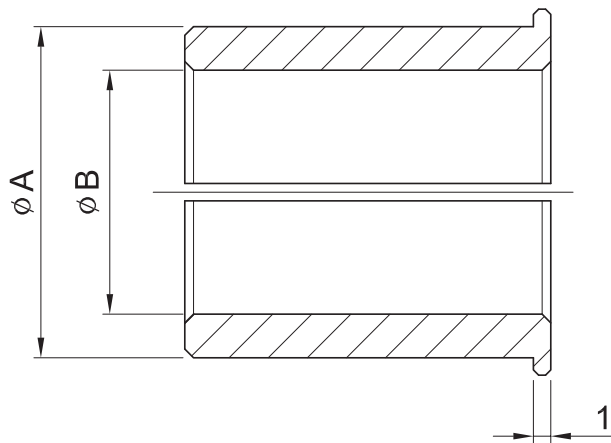

軸套內徑為所使用伺服馬達的輸出軸軸徑。下表中沒有的情況下需要插入軸套，在您所使用的輸出軸軸徑的近似值中選擇大值。

連接軸 孔徑 Shaft Bore $\varnothing B$ 軸套 孔徑 Bushing Bore $\varnothing A$	8	11	14	19	22	24	28	35	38	42	48
5	●										
5.65		●									
6	●	●	●								
6.35	●		●								
8		●	●								
9		●	●								
9.5				●							
10			●	●							
11			●	●							
12			●	●							
12.7			●	●							
14				●		●					
16				●		●	●				
19					●	●	●				
22						●	●	●			
22.22									●		
24							●	●			
25							●				
28								●		●	
32								●	●		
35									●	●	
38										●	
42											●

Collet Locking Mechanism

筒夾式連結機構

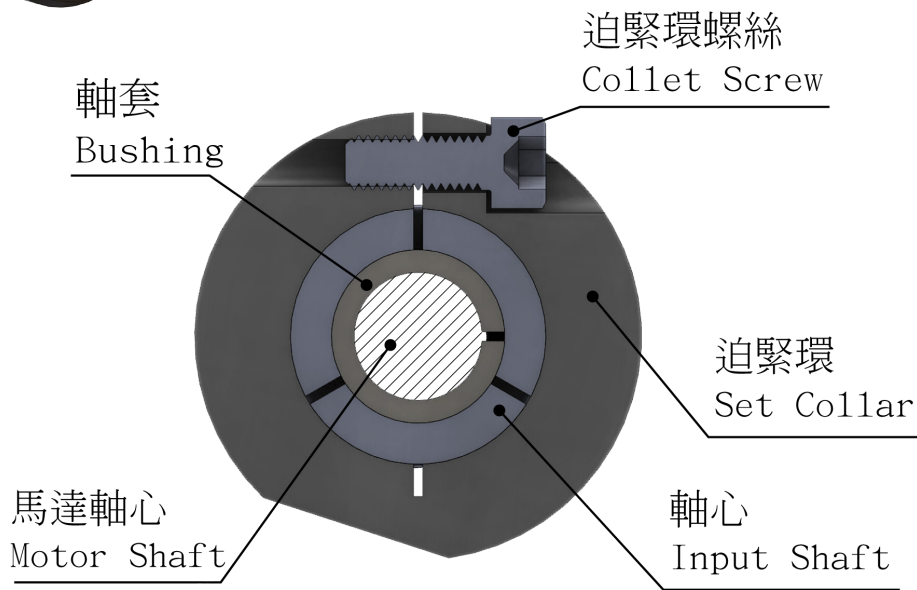

迫緊環螺絲及迫緊環扭矩表 Collet Screw & Collar Torque Table

型號 Model				迫緊環螺絲規格 Spec. of Collet Screw	螺絲強度等級 Screw Grade	螺絲鎖緊扭矩 Tighten Torque (Nm)	迫緊扭矩 Clench Torque (Nm)
ST	HY	WE ANE	GT				
-	55	30 40	60 85	M4 x P0.7	12.9	4.83	87
65 75	75	50	110 135 200(雙段 2-Stage)	M5 x P0.8	12.9	10	164
90 110	90	60 70	200(單段 1-Stage)	M6 x P1.0	12.9	16.3	233
140	115 130	-	-	M8 x P1.25	12.9	41	423
170 210	140 160 190	-	-	M10 x P1.5	12.9	81	678

※ 馬達扭矩超過迫緊環扭矩時，可能導致打滑。It will cause slip when motor torque exceed clench torque.

Clamping Sets

免鍵式軸套組



免鍵式軸套組 Clamping sets

型號 Model			出力軸孔徑 Output Bore (mm)	螺絲規格 Spec. of Screw	螺絲強度等級 Screw Grade	螺絲鎖緊扭矩 Tighten Torque (Nm)	迫緊扭矩 Clench Torque (Nm)	螺絲數量 Quantity of Screw
ST	HY	WE						
65 75	-	30	Ø14	M6 x P1.0	12.9	16.3	127.53	6
90	-	-	Ø18	M6 x P1.0	12.9	16.3	196.2	6
-	55	40	Ø20	M6 x P1.0	12.9	16.3	196.2	6
110	-	-	Ø22	M6 x P1.0	12.9	16.3	353.6	8
-	75	50 60	Ø25	M6 x P1.0	12.9	16.3	353.6	8
-	90	70	Ø30	M6 x P1.0	12.9	16.3	353.6	8
140	-	-	Ø32	M6 x P1.0	12.9	16.3	735.75	8
170	115	-	Ø40	M8 x P1.25	12.9	41	882	8
-	130	-	Ø48	M8 x P1.25	12.9	41	882	8
210	-	-	Ø50	M8 x P1.25	12.9	41	1400	8
-	140	-	Ø55	M8 x P1.25	12.9	41	1600	8
-	160	-	Ø60	M8 x P1.25	12.9	41	2200	8
-	190	-	Ø70	M10 x P1.5	12.9	81	2880	8

Selection Table of Motor for Reference

馬達選用參考表

單段 1-Stage

型號 Model	ST	-	-	65、75	-	90	110	140	170	-	210
	FT	-	60	70	-	-	-	-	-	-	-
	HY	-	55	75	90	115	-	130	140	160	190
	WE	-	30	40	50	60、70	-	-	-	-	-
	GT	60	-	85、110	135	200	-	-	-	-	-
入力孔徑 Input Bore		8	8、9、11	14	14、19	19、24	22、24	28、32	35	38	42、48、55
容量 Power											
100 W	●	●	●	●							
200 W			●	●							
400 W			●	●							
750 W				●	●						
1 kW					●	●					
1.5 kW					●	●					
2.2 kW							●				
3.75 kW							●	●			
5.5 kW								●	●		
7.5 kW									●		
11 kW										●	
15 kW											●
22 kW											●

雙段 2-Stage

型號 Model	ST	-	65、75	75	90、110	140	170	210	-		
	FT	-	60、70	70	-	-	-	-	-		
	HY	-	55	75、90	115	130	140、160	190			
	GT	60	-	85、110、135	-	200	-	-	-		
入力孔徑 Input Bore		8	8、9、11	14	14、19	19、24	22、24	28、32	35	38	42、48、55
容量 Power											
100 W	●	●	●	●							
200 W			●	●							
400 W			●	●							
750 W				●	●						
1 kW					●	●					
1.5 kW					●	●					
2.2 kW							●				
3.75 kW							●	●			
5.5 kW								●	●		
7.5 kW									●		
11 kW										●	
15 kW										●	
22 kW										●	

LIMING REDUCERS

利明牌減速機系列產品

伺服用減速機 Reducers for Servo Motor

高精度行星減速機 High Precision Planetary Reducers

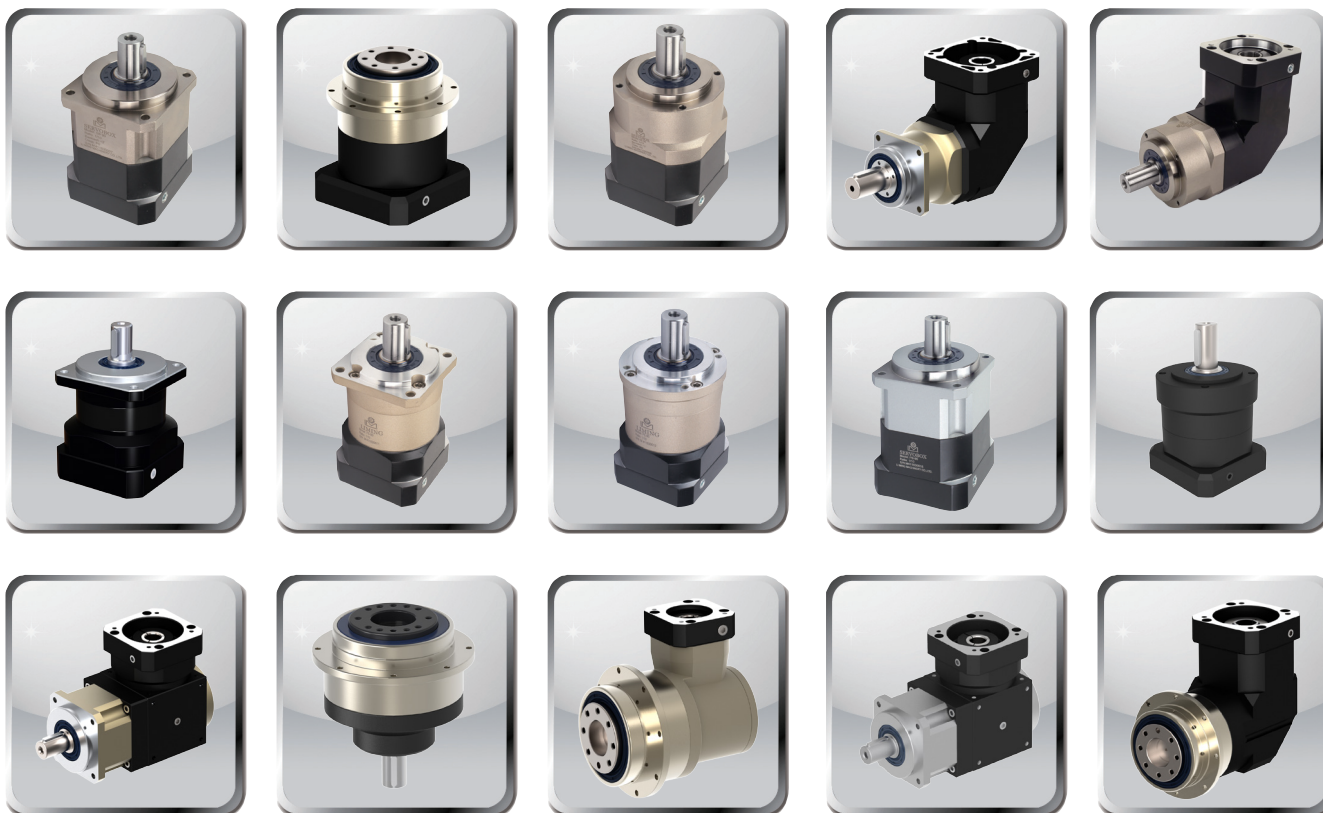

直交軸伺服用減速機
High Precision Right Angle Reducers

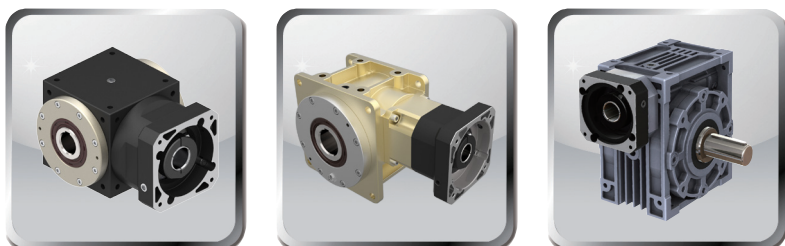

諧波減速機
Harmonic Reducers



高精度擺線減速機
High Precision Cycloidal Reducers



伺服用中空旋轉平台減速機
Hollow Rotary Actuator Reducers

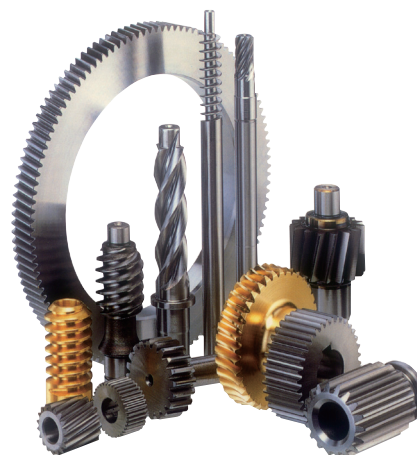
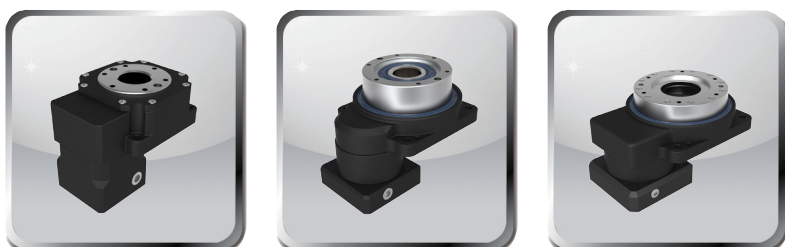

LIMING REDUCERS

利明牌減速機系列產品

一般傳動減速機 General Speed Reducers

齒輪減速機 Gear Reducers



蝸輪減速機 Worm Gear Reducers



電梯主機 Traction Machine

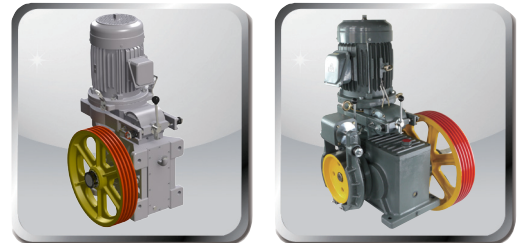

一般傳動減速機 Reducers



傳動軸用減速機 Gearbox for Power Transmission



Inquiry Information

顧客詢問資料

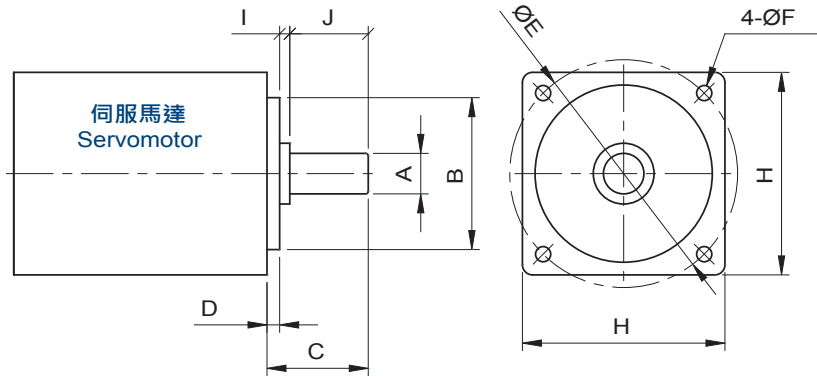

A	B	C	D	E	F	H	I	J

行星速機訂購編號

<input type="text"/>	—	<input type="text"/>	—	<input type="text"/>	<input type="text"/>	—	<input type="text"/>	—	<input type="text"/>
減速機型 Type		型號 Model		速比 Ratio	出力軸鍵槽 Output Shaft Keyway		背隙等級 Backlash Class		馬達型號 MOTOR NO.

訂貨須知：

- ◆機種、型號、馬力
- ◆減速比或每分鐘回轉數
- ◆荷重狀況及聯結方式
- ◆數量及被安裝的機械名稱
- ◆入力方式和入力轉速
- ◆馬達廠牌型號或法蘭及馬達軸尺寸

General Notices:

- ◆ Type, model and horsepower
- ◆ Speed ratio or R.P.M of output shaft
- ◆ Method of connection and loading
- ◆ Quantity and applied mechanism
- ◆ Input connection method and input speed
- ◆ Motor band Model no or frame & motor shaft dimension

公司名稱 Company Name		聯絡人 Contact Person	
地址 Address			
電話 Tel	傳真 Fax	電子信箱 E-Mail	
備註 Notes			

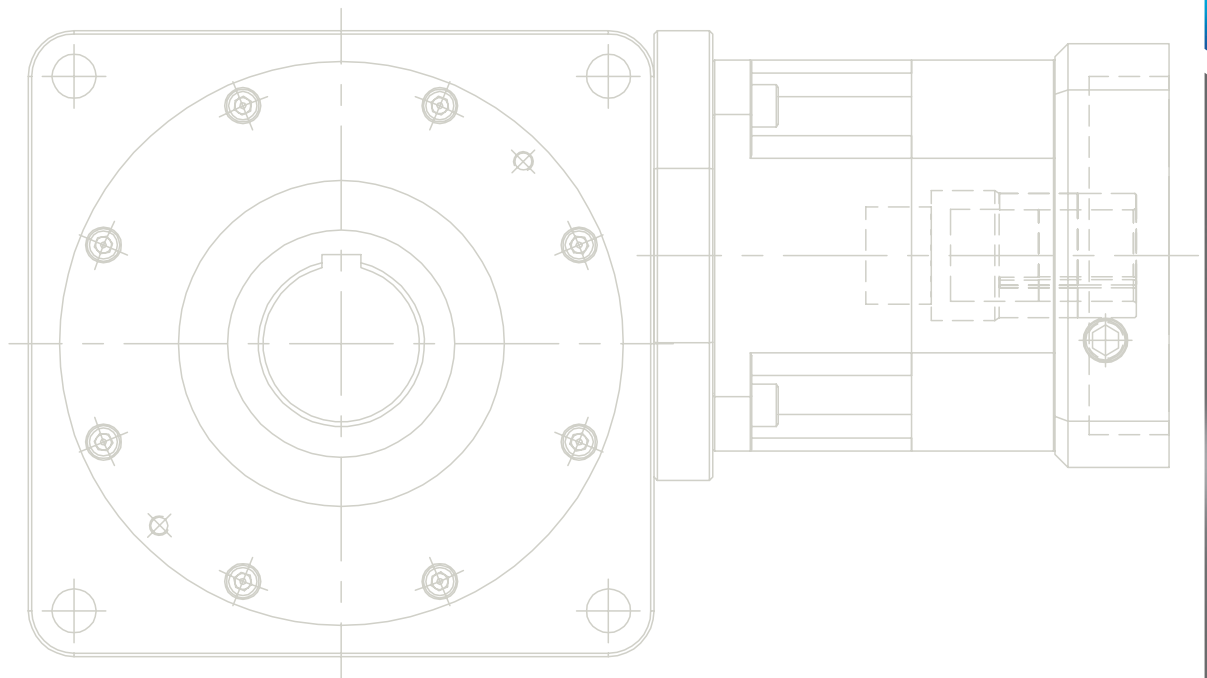

2019 年 6 月版

- 由於產品改良，未經通告變更印刷製品規格，請諒察。
- 由於印刷特性與拍攝技術的關係，印刷顏色與實物稍有差異，請諒察。
- 產品專利及版權所有，非經本公司同意，不得轉載本刊任何圖文或仿冒商品。
- 本目錄於製作時已力求完美，但因機種繁多，校稿疏失在所難免，請於訂貨時與業務人員進行確認。

June, 2019

- We ask for your understanding if due to product improvements and the product in this catalogue have not yet been update.
- We also ask for your understanding if due to printing limitations the objects and colors in this catalogue do not match the actual products exactly.
- The products in this catalogue have been registered with the patents office.
- The reprinting of this publication in any form or the imitation of any of the products described within is expressly forbidden without the express permission of the LI MING MACHINERY CO., LTD.

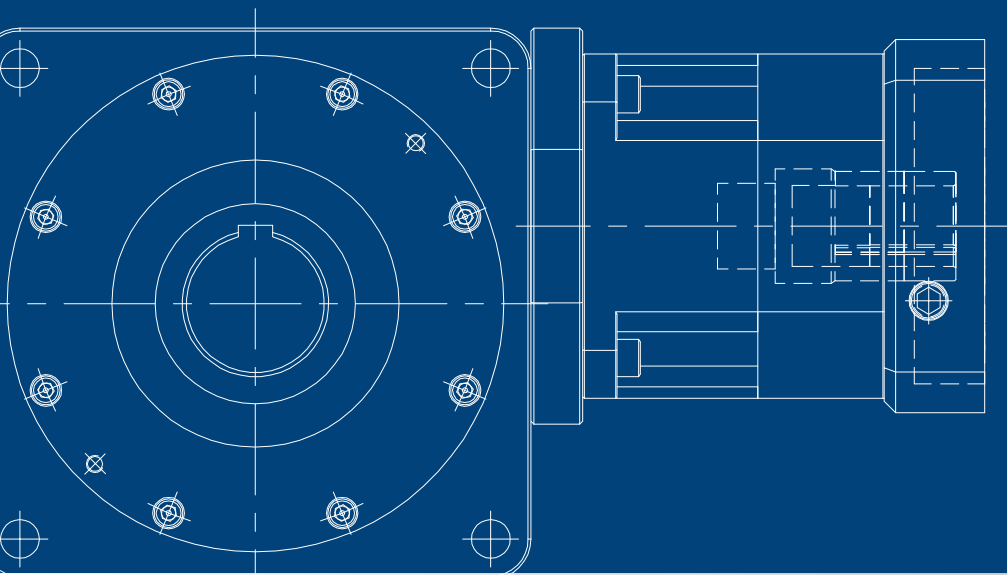

利明牌
高精密伺服用直交軸減速機 & 高精密中空旋轉平台減速機

High Accuracy & Efficiency Profit

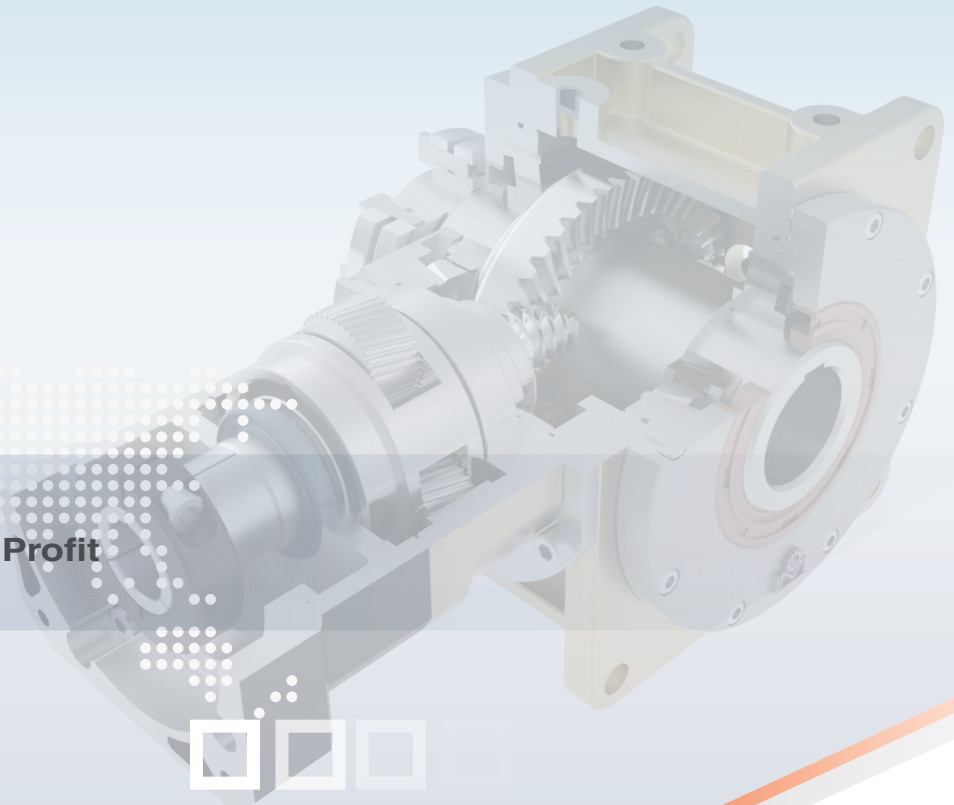

利茗機械股份有限公司
LI MING MACHINERY CO., LTD.

台中市潭子區潭富路一段168號
No. 168, SEC. 1, Tan Fu RD.,
Tan Tzu DIST., Taichung City 42753, Taiwan
Tel:886-4-25314888 Fax:886-4-25338982
<http://www.li-ming.com> E-mail:info@li-ming.com

